

MEMORANDUM

TO: Board of Trustees

THROUGH: Bobby Magee, District General Manager

FROM: Kate Nelson, Interim Director of Public Works

SUBJECT: Review, Discuss and Approve the Construction Agreement for the Sewer Pump Station #5 Wetwell and Manhole Rehabilitation Project - 2023/24 Capital Improvement Project Fund: Utilities; Division: Sewer: Project #2599DI1104, Sewer Pumping Station Improvements, and Project #2599SS1203X, Replace and Reline Sewer Mains, Manholes and Appurtenances; Contractor: Farr Construction Corporation dba Resource Development Company, in the Amount of \$152,500. (Requesting Staff Member: Interim Public Works Director Kate Nelson)

RELATED FY 2023 STRATEGIC PLAN

LONG RANGE PRINCIPLE #5 – ASSETS AND INFRASTRUCTURE

BUDGET INITIATIVE(S): The District will practice perpetual asset renewal, replacement and improvement to provide safe and superior long term utility services and recreation venues, facilities, and services. Maintain, renew, expand and enhance district infrastructure to meet the capacity needs and desires of the community for future generations.

RELATED DISTRICT POLICIES, PRACTICES, RESOLUTIONS OR ORDINANCES

Ordinance No. 2 – Sewer Ordinance, Purchasing Policy for Public Works Contracts 21.2.0.

DATE: June 26, 2024

I. RECOMMENDATION

The Board of Trustees make a Motion to:

1. Approve the Award of a Construction Contract for the SPS #5 Wetwell and Manhole Rehabilitation Project - 2022/2023 Capital Project Fund: Utilities; Division: Sewer: Project #2599DI1104, Sewer Pumping Station

Improvements, and Project #2599SS1203X, Replace & Reline Sewer Mains, Manholes and Appurtenances; Contractor: Farr Construction Corporation dba Resource Development Company, in the Amount of \$152,500; and,

2. Authorize Staff to Execute Change Orders for Additional Work for 10% of the Construction Contract in the Amount of \$15,250; and,
3. Direct the Chair and Secretary to Sign and Execute the Contract.

II. BACKGROUND

Sewer Pump Station #5 (SPS #5) wetwell and the upstream manhole were installed along the shore of Lake Tahoe in 1965. SPS #5 is a 4-foot diameter steel wetwell with a Smith and Loveless pump station. The pump station pumps sewage from the forty-four upstream properties up to the sewer line on Lakeshore Blvd., where it then gravity flows to SPS #1. SPS #5 and the upstream manhole need to be sandblasted and re-coated to extend their life expectancy. Both the wetwell's and the manhole's coatings were tested for lead paint. The lead test results indicated an amount of lead in the existing paint that requires lead abatement in accordance with OSHA 1926.62.

SPS #5 is currently accessible because the property to the west of the project is under construction. Once the house has been completed in the autumn of 2024, access to SPS #5 with equipment will be heavily restricted and may require approach from the lake.

III. BID RESULTS

The District publicly advertised the Project for bidding in accordance with NRS 338 on May 17, 2024 with a bid opening on May 29, 2024. The Engineer's Estimate for the total project's cost was \$200,000. The lowest responsive bid was submitted by Resource Development Company for an amount of \$152,500. The District received two responsive bids ranging from \$152,500 to \$244,300.

The bid was comprised of a Base Bid and two Bid Alternates. The Base Bid includes the work to recoat and rehabilitate the SPS #5 wetwell and upstream manhole. Bid Alternate #1 and Bid Alternate #2 are the bypass pumping of the sewage for the SPS #5 wetwell and the upstream manhole consecutively.

IV. FINANCIAL IMPACT AND BUDGET

SPS #5 Wetwell and Manhole Rehabilitation Project is being funded by two CIP Projects: Project #2599DI1104, Sewer Pumping Station Improvements, and Project #2599SS1203X, Replace and Reline Sewer Mains, Manholes and Appurtenances which were included in the Board approved FY 2023/24 CIP Budget.

The proposed construction agreement for the project is provided in Attachment 1.

V. ALTERNATIVES

There are no suggested alternatives.

VI. COMMENTS

The Agreement between the District and Farr Construction Corporation dba Resource Development Company has been reviewed and approved by District Legal Counsel.

VII. BUSINESS IMPACT/BENEFIT

This item is not a "rule" within the meaning of Nevada Revised Statutes, Chapter 237, and does not require a Business Impact Statement.

VIII. ATTACHMENTS

1. SPS #5 Contract

IX. DECISION POINTS NEEDED FROM THE BOARD OF TRUSTEES



**Contract Documents
for
SEWER PUMP STATION 5
WETWELL AND MANHOLE REHABILITATION**

IVGID Project Number 2299DI1104
PWP No. WA-2024-055

Issued for Construction

June 27, 2024

Prepared for:

INCLINE VILLAGE GENERAL IMPROVEMENT DISTRICT
Public Works Department

Prepared by:

INCLINE VILLAGE GENERAL IMPROVEMENT DISTRICT
Engineering Division
1220 Sweetwater Road
Incline Village, Nevada 89451

TABLE OF CONTENTS

Contract Documents

<u>Section</u>	<u>Description</u>	<u>Pages</u>
1	Invitation to Bid.....	2
2	Instructions to Bidders.....	12
3	Bid Form	10
4	Bid Bond	2
5	Agreement	8
6	Application and Certificate for Payment	2
7	Performance Bond.....	2
8	Payment Bond	2
9	Standard General Conditions.....	48
10	Supplementary Conditions	16
11	Washoe County 2023/2024 Prevailing Wage Rates.....	38
12	Technical Specifications..... See Technical Table of Contents	

ADVERTISEMENT FOR BIDS

Lump Sum Proposals via PlanetBids will be received by the Incline Village General Improvement District (IVGID or District) Public Works Department until 3:00 p.m. **May 29, 2024**, for:

SPS #5 Wetwell and Manhole Rehabilitation IVGID Project Number 2599DI1104

Said Proposal shall include all labor, tools, implements, machinery, materials, and any incidentals necessary to complete the work in the manner and time prescribed, and in strict conformity with the Contract Documents, to the satisfaction of the District Engineer. The Project includes the following Work:

Rehabilitation and improvements to IVGID's Sewer Pump Station 5 steel wetwell and adjacent concrete manhole, located at 835 Lakeshore Boulevard in Incline Village, Washoe County, Nevada. Rehabilitation improvements include:

1. Providing a temporary bypass of manhole and wetwell, as required.
2. Steel wetwell contains lead in existing coating and must be abated per applicable OSHA and EPA requirements.
3. Prepare steel wetwell and concrete manhole surfaces and complete application of a new epoxy polymer lining system.

Owner anticipates that the Project's total bid price will be approximately \$200,000. The Project has an expected duration of 45 days.

The Bidders attention is directed to Nevada Revised Statutes 338.01165, which sets forth the requirements for the use of apprentices on public works and requires a contractor or subcontractor to comply with certain requirements relating to the use of apprentices on public works.

Digital copies of the plans, specifications and related documents are available through the District's PlanetBids portal at <https://pbsystem.planetbids.com/portal/30437/portal-home>. Only those bidders who have registered as a vendor and are included in and appear on the prospective bidders list may submit a bid.

This is a Prevailing Wage project. In accordance with the provisions of NRS 338, the IVGID Board of Trustees has ascertained from the Labor Commissioner the general prevailing wage in the locality of the District for each craft and type of workman, and the CONTRACT will contain in express terms the hourly and daily rate of such prevailing wage. The PWP number for this project is WA-2024-055.

No proposal will be accepted from a Contractor who is not licensed in accordance with the laws of this State to perform the work herein described. IVGID reserves the right to reject any or all bids pursuant to Nevada Law; to award a contract for less than all the work if funds now available are insufficient for completion of the total project; to waive any informalities or irregularities therein; and/or to award the bid to the lowest responsible bidder.

A **mandatory** pre-bid conference will be held on **May 22, 2024 at 10:00 a.m.** at the project site, 835 Lakeshore Boulevard, in Incline Village, Washoe County Nevada. All potential bidders are required to attend.

All questions and RFIs should be directed through the District's Planet Bids portal. Final date for receipt of any questions is May 24, 2024, by 3:00 p.m. For assistance with Planet Bids or downloading of documents, contact the IVGID Engineering office at 775-832-1267.

INSTRUCTIONS TO BIDDERS

ARTICLE 1—DEFINED TERMS

- 1.01 Terms used in these Instructions to Bidders have the meanings indicated in the General Conditions and Supplementary Conditions. Additional terms used in these Instructions to Bidders have the meanings indicated below:
- A. *Issuing Office*—The office from which the Bidding Documents are to be issued, and which registers plan holders.

ARTICLE 2—BIDDING DOCUMENTS

- 2.01 Bidder shall obtain a complete set of Bidding Requirements and proposed Contract Documents (together, the Bidding Documents) through the District's PlanetBids portal at <https://pbsystem.planetbids.com/portal/30437/portal-home>. See Section 5 - Agreement for a list of the Contract Documents. It is Bidder's responsibility to determine that it is using a complete set of documents in the preparation of a Bid. Bidder assumes sole responsibility for errors or misinterpretations resulting from the use of incomplete documents, by Bidder itself or by its prospective Subcontractors and Suppliers.
- 2.02 Bidding Documents are made available for the sole purpose of obtaining Bids for completion of the Project, and permission to download or distribution of the Bidding Documents does not confer a license or grant permission or authorization for any other use. Authorization to download documents, or other distribution, includes the right for plan holders to print documents solely for their use, and the use of their prospective Subcontractors and Suppliers, provided the plan holder pays all costs associated with printing or reproduction. Printed documents may not be re-sold under any circumstances.
- 2.03 Owner has established a Planet Bids Bidding Documents Website as indicated in the Invitation to Bid. Owner recommends that Bidder register as a plan holder with the Planet Bids website, and obtain a complete set of the Bidding Documents from such website. Bidders may rely that sets of Bidding Documents obtained from the Bidding Documents Website are complete, unless an omission is blatant. Registered plan holders will receive notices of any Addenda issued by Owner.
- 2.04 Plan rooms (including construction information subscription services, and electronic and virtual plan rooms) may distribute the Bidding Documents, or make them available for examination. Those prospective bidders that obtain an electronic (digital) copy of the Bidding Documents from a plan room are encouraged to register as plan holders on the District's Planet Bids Bidding Documents Website. Owner is not responsible for omissions in Bidding Documents or other documents obtained from plan rooms, or for a Bidder's failure to obtain Addenda from a plan room.
- 2.05 *Electronic Documents*
- A. When the Bidding Requirements indicate that electronic (digital) copies of the Bidding Documents are available, such documents will be made available to the Bidders as Electronic Documents in the manner specified above.
1. Bidding Documents will be provided in Adobe PDF (Portable Document Format) (.pdf) that is readable by Adobe Acrobat Reader Version XI Standard or later. It is the intent of

the Engineer and Owner that such Electronic Documents are to be exactly representative of the paper copies of the documents. However, because the Owner and Engineer cannot totally control the transmission and receipt of Electronic Documents nor the Contractor's means of reproduction of such documents, the Owner and Engineer cannot and do not guarantee that Electronic Documents and reproductions prepared from those versions are identical in every manner to the paper copies.

- B. Unless otherwise stated in the Bidding Documents, the Bidder may use and rely upon complete sets of Electronic Documents of the Bidding Documents, described in Paragraph 2.05.A above. However, Bidder assumes all risks associated with differences arising from transmission/receipt of Electronic Documents versions of Bidding Documents and reproductions prepared from those versions and, further, assumes all risks, costs, and responsibility associated with use of the Electronic Documents versions to derive information that is not explicitly contained in printed paper versions of the documents, and for Bidder's reliance upon such derived information.

ARTICLE 3—QUALIFICATIONS OF BIDDERS

3.01 To demonstrate Bidder's qualifications to perform the Work, after submitting its Bid and within 48 hours of Owner's request, Bidder must submit the following information:

- A. Written evidence establishing its qualifications such as financial data, previous experience, and present commitments.
- B. A written statement that Bidder is authorized to do business in the state where the Project is located, or a written certification that Bidder will obtain such authority prior to the Effective Date of the Contract.
- C. Washoe County Business License prior to commencing construction.
- D. Bidder shall have specific experience in the application of protective epoxy lining systems; the Bidder or their Applicator shall be trained by the protective lining materials manufacturer and provide documentation stating they are approved by the protective lining manufacturer.
- E. Such licenses as may be required by the laws of the State of Nevada for the performance of work specified in the Contract Documents. Such licenses are required at the time of submitting bid. One time raise in licensing monetary limits shall be approved by the State of Nevada prior to the time of submitting bid and shall be submitted with the bid.
- F. Each Bidder submitting a Bid Proposal to the Owner on a public work project whose estimated cost exceeds \$250,000 is responsible for ascertaining whether the Bidder intends to utilize the referenced statute for five percent (5%) preference and is also eligible for the bidder preference and other matters relating thereto provided in NRS Chapter 338.0117. The Bidder claiming the bid preference shall submit with their Bid Form:
 - 1. Certificate of Eligibility: A valid "Certificate of Eligibility" issued by the State of Nevada Contractor's Board, and
 - 2. Public Works Bidder's Preference Affidavit: A fully-executed copy of the Public Works Bidder's Preference Affidavit as proof of the Contractor's compliance with the provisions of NRS 338.

Failure to submit the Certificate of Eligibility and Affidavit with your Bid shall result in a waiver of any Bidder preference.

3.02 *Bid Form:*

- A. Bidder is to submit the following information with its Bid, to demonstrate Bidder's qualifications to perform the Work. Bids without such documentation included will be deemed Non-Responsive:
1. A list of all first-tier subcontractors, equipment, and materials suppliers that will supply more than five percent (5%) of the bid amount. If the Contractor intends to self-perform any portion of the Work exceeding five percent (5%) of the Bid Amount, the Contractor must also include the Contractor's name and identify the labor or portion of the Work the Contractor will self-perform in the list, as required by NRS 338.141.
 2. Within two (2) hours after the opening of Bids, those bidders submitting the three lowest Bids must submit the names of each first-tier subcontractor, equipment and material supplier that will supply more than 1% of the bid amount, or Fifty Thousand Dollars (\$50,000), whichever is greater. If the Contractor intends to self-perform any portion of the Work exceeding one percent (1%) of the Bid Amount or Fifty Thousand Dollars (\$50,000), whichever is greater, the Contractor must also include the Contractor's name and identify the labor or portion of the Work the Contractor will self-perform in the list, as required by NRS 338.141.
 3. A list of similar projects previously completed by Bidder, including contact person with their telephone number and email, and the date the project was completed.
 - a. Contractor is required to have successfully performed five (5) projects of similar scope within the last five (5) years, including a minimum project total cost of \$200,000, contract time of 15 to 60 days, and preferably work performed in the Lake Tahoe basin.
 4. Work history of Job Foreman/Superintendent, Pipe Foreman and Equipment Operator.
 - a. Contractor is required to staff project with a Job Foreman/Superintendent with minimum experience of five (5) years' experience with similar project work and five (5) projects within five (5) years greater than \$200,000.
 5. Bidder's state or other contractor license number, if applicable.

3.03 A Bidder's failure to submit required qualification information within the times indicated will result in the Bid being deemed Non-Responsive.

3.04 No requirement in this Article 3 to submit information will prejudice the right of Owner to seek additional pertinent information regarding Bidder's qualifications.

ARTICLE 4—PRE-BID CONFERENCE

4.01 A non-mandatory pre-bid conference will be held at the time and location indicated in the Invitation to Bid. Representatives of Owner and Engineer will be present to discuss the Project.

4.02 Information presented at the pre-bid conference does not alter the Contract Documents. Owner will issue Addenda to make any changes to the Contract Documents that result from discussions at the pre-bid conference. Information presented, and statements made at the pre-bid conference will not be binding or legally effective unless incorporated in an Addendum.

ARTICLE 5—SITE AND OTHER AREAS; EXISTING SITE CONDITIONS; EXAMINATION OF SITE; OWNER'S SAFETY PROGRAM; OTHER WORK AT THE SITE

5.01 *Site and Other Areas*

- A. The Site is identified in the Bidding Documents. By definition, the Site includes rights-of-way, easements, and other lands furnished by Owner for the use of the Contractor. Any additional lands required for temporary construction facilities, construction equipment, or storage of materials and equipment, and any access needed for such additional lands, are to be obtained and paid for by Contractor.

5.02 *Existing Site Conditions*

A. *Subsurface and Physical Conditions; Hazardous Environmental Conditions*

1. The Supplementary Conditions identify the following regarding existing conditions at or adjacent to the Site:
 - a. Those reports of explorations and tests of subsurface conditions at or adjacent to the Site that contain Technical Data.
 - b. Those drawings known to Owner of existing physical conditions at or adjacent to the Site, including those drawings depicting existing surface or subsurface structures at or adjacent to the Site (except Underground Facilities), that contain Technical Data.
 - c. Reports and drawings known to Owner relating to Hazardous Environmental Conditions that have been identified at or adjacent to the Site.
 - d. Technical Data contained in such reports and drawings.
2. Owner will make copies of reports and drawings referenced above available to any Bidder on request. These reports and drawings are not part of the Contract Documents, but the Technical Data contained therein upon whose accuracy Bidder is entitled to rely, as provided in the General Conditions, has been identified and established in the Supplementary Conditions. Bidder is responsible for any interpretation or conclusion Bidder draws from any Technical Data or any other data, interpretations, opinions, or information contained in such reports or shown or indicated in such drawings.
3. If the Supplementary Conditions do not identify Technical Data, the default definition of Technical Data set forth in Article 1 of the General Conditions will apply.
4. *Geotechnical Baseline Report/Geotechnical Data Report: NOT USED*

- B. *Underground Facilities:* Underground Facilities are shown or indicated on the Drawings, pursuant to Paragraph 5.05 of the General Conditions, and not in the drawings referred to in Paragraph 5.02.A of these Instructions to Bidders. Information and data regarding the presence or location of Underground Facilities are not intended to be categorized, identified, or defined as Technical Data.

5.03 *Other Site-related Documents*

- A. In addition to the documents regarding existing Site conditions referred to in Paragraph 5.02.A, the following other documents relating to conditions at or adjacent to the Site are known to Owner and made available to Bidders for reference:

Owner will make copies of these other Site-related documents available to any Bidder on request.

- B. Owner has not verified the contents of these other Site-related documents, and Bidder may not rely on the accuracy of any data or information in such documents. Bidder is responsible for any interpretation or conclusion Bidder draws from the other Site-related documents.
- C. The other Site-related documents are not part of the Contract Documents.
- D. Bidders are encouraged to review the other Site-related documents, but Bidders will not be held accountable for any data or information in such documents. The requirement to review and take responsibility for documentary Site information is limited to information in (1) the Contract Documents and (2) the Technical Data.

5.04 *Site Visit and Testing by Bidders*

- A. It is recommended that Bidder visit the Site and become familiar with and satisfy Bidder as to the general, local and Site conditions that may affect cost, progress, and performance of the Work.
- B. Bidder is not required to conduct any subsurface testing, or exhaustive investigations of Site conditions.
- C. On request, and to the extent Owner has control over the Site, and schedule permitting, the Owner will provide Bidder general access to the Site to conduct such additional examinations, investigations, explorations, tests, and studies as Bidder deems necessary for preparing and submitting a successful Bid. Owner will not have any obligation to grant such access if doing so is not practical because of existing operations, security or safety concerns, or restraints on Owner's authority regarding the Site. Bidder is responsible for establishing access needed to reach specific selected test sites.
- D. Bidder must comply with all applicable Laws and Regulations regarding excavation and location of utilities, obtain all permits, and comply with all terms and conditions established by Owner or by property owners or other entities controlling the Site with respect to schedule, access, existing operations, security, liability insurance, and applicable safety programs.
- E. Bidder must fill all holes and clean up and restore the Site to its former condition upon completion of such explorations, investigations, tests, and studies.

5.05 *Owner's Safety Program*

- A. Site visits and work at the Site may be governed by an Owner safety program. If an Owner safety program exists, it will be noted in the Supplementary Conditions.

5.06 *Other Work at the Site*

- A. Reference is made to Article 8 of the Supplementary Conditions for the identification of the general nature of other work of which Owner is aware (if any) that is to be performed at the Site by Owner or others (such as utilities and other prime contractors) and relates to the Work contemplated by these Bidding Documents. If Owner is party to a written contract for such other work, then on request, Owner will provide to each Bidder access to examine such contracts (other than portions thereof related to price and other confidential matters), if any.

ARTICLE 6—BIDDER’S REPRESENTATIONS AND CERTIFICATIONS

6.01 *Express Representations and Certifications in Bid Form, Agreement*

- A. The Bid Form that each Bidder will submit contains express representations regarding the Bidder’s examination of Project documentation, Site visit, and preparation of the Bid, and certifications regarding lack of collusion or fraud in connection with the Bid. Bidder should review these representations and certifications, and assure that Bidder can make the representations and certifications in good faith, before executing and submitting its Bid.
- B. If Bidder is awarded the Contract, Bidder (as Contractor) will make similar express representations and certifications when it executes the Agreement.

ARTICLE 7—INTERPRETATIONS AND ADDENDA

- 7.01 Owner on its own initiative may issue Addenda to clarify, correct, supplement, or change the Bidding Documents.
- 7.02 Bidder shall submit all questions about the meaning or intent of the Bidding Documents to Engineer through Owner’s Planet Bids website. The closing date to submit questions is shown on the Advertisement to Bid.
- 7.03 Interpretations or clarifications considered necessary by Engineer in response to such questions will be issued by Addenda delivered to all registered plan holders. Questions received less than seven days prior to the date for opening of Bids may not be answered.
- 7.04 Only responses set forth in an Addendum will be binding. Oral and other interpretations or clarifications will be without legal effect. Responses to questions are not part of the Contract Documents unless set forth in an Addendum that expressly modifies or supplements the Contract Documents.

ARTICLE 8—BID SECURITY

- 8.01 A Bid must be accompanied by bid security made payable to Owner in an amount of five percent (5%) of Bidder’s maximum Bid price (determined by adding the base bid and all alternates) and in the form of a bid bond issued by a surety meeting the requirements of Paragraph 6.01 of the General Conditions. Such bid bond will be issued in the form included in the Bidding Documents.
 - A. A copy of the bid security must be submitted with Bidder’s bid price on Planet Bids, and the original Bid Security must be mailed or hand-delivered to:
 - IVGID Public Works
 - 1220 Sweetwater Road
 - Incline Village NV 89451
 - Attn: R. Rector.
 - B. Postmark or hand-delivery of Bid Security must be the same date as Bid Date or the bid will be deemed nonresponsive.
- 8.02 The Bid security of the apparent Successful Bidder will be retained until Owner awards the contract to such Bidder, and such Bidder has executed the Contract, furnished the required Contract security, and met the other conditions of the Notice of Award, whereupon the Bid security will be released. If the Successful Bidder fails to execute and deliver the Contract and

furnish the required Contract security within 15 days after the Notice of Award, Owner may consider Bidder to be in default, annul the Notice of Award, and the Bid security of that Bidder will be forfeited, in whole in the case of a penal sum bid bond, and to the extent of Owner's damages in the case of a damages-form bond. Such forfeiture will be Owner's exclusive remedy if Bidder defaults.

- 8.03 The Bid security of other Bidders that Owner believes to have a reasonable chance of receiving the award may be retained by Owner until the earlier of 7 days after the Effective Date of the Contract or 61 days after the Bid opening, whereupon Bid security furnished by such Bidders will be released.
- 8.04 Bid security of other Bidders that Owner believes do not have a reasonable chance of receiving the award will be released within 7 days after the Bid opening.

ARTICLE 9—CONTRACT TIMES

- 9.01 The number of days within which, or the dates by which, the Work is to be (a) substantially completed and (b) ready for final payment, and (c) Milestones (if any) are to be achieved, are set forth in the Agreement.
- 9.02 Provisions for liquidated damages, if any, for failure to timely attain a Milestone, Substantial Completion, or completion of the Work in readiness for final payment, are set forth in the Agreement.

ARTICLE 10—SUBSTITUTE AND "OR EQUAL" ITEMS

- 10.01 The Contract for the Work, as awarded, will be on the basis of materials and equipment specified or described in the Bidding Documents without consideration during the bidding and Contract award process of possible substitute or "or-equal" items. In cases in which the Contract allows the Contractor to request that Engineer authorize the use of a substitute or "or-equal" item of material or equipment, application for such acceptance may not be made to and will not be considered by Engineer until after the Effective Date of the Contract.
- 10.02 All prices that Bidder sets forth in its Bid will be based on the presumption that the Contractor will furnish the materials and equipment specified or described in the Bidding Documents, as supplemented by Addenda. Any assumptions regarding the possibility of post-Bid approvals of "or-equal" or substitution requests are made at Bidder's sole risk.

ARTICLE 11—SUBCONTRACTORS, SUPPLIERS, AND OTHERS

- 11.01 If the Instructions to Bidders require the identity of certain Subcontractors, Suppliers, individuals, or entities to be submitted to Owner in advance of a specified date prior to the Effective Date of the Agreement, the apparent Successful Bidder, and any other Bidder so requested, shall submit to Owner a list of all such Subcontractors, Suppliers, individuals, or entities proposed for those portions of the Work for which such identification is required.
- 11.02 If requested by Owner, such list must be accompanied by an experience statement with pertinent information regarding similar projects and other evidence of qualification for each such Subcontractor or Supplier. If Owner or Engineer, after due investigation, has reasonable objection to any proposed Subcontractor or Supplier, Owner may, before the Notice of Award is given, request apparent Successful Bidder to submit an acceptable substitute, in which case apparent

Successful Bidder will submit a substitute, Bidder's Bid price will be increased (or decreased) by the difference in cost occasioned by such substitution, and Owner may consider such price adjustment in evaluating Bids and making the Contract award.

- 11.03 If apparent Successful Bidder declines to make any such substitution, Owner may award the Contract to the next lowest Bidder that proposes to use acceptable Subcontractors and Suppliers. Declining to make requested substitutions will constitute grounds for forfeiture of the Bid security of any Bidder. Any Subcontractor or Supplier, so listed and against which Owner or Engineer makes no written objection prior to the giving of the Notice of Award will be deemed acceptable to Owner and Engineer subject to subsequent revocation of such acceptance as provided in Paragraph 7.07 of the General Conditions.
- 11.04 Contractor shall not be required to employ any Subcontractor, Supplier, individual or entity against whom Contractor has reasonable objection.

ARTICLE 12—PREPARATION OF BID

- 12.01 The Bid Form is included as Section 3 of the Bidding Documents.
- A. All blanks on the Bid Form must be completed in ink and the Bid Form signed in ink. Erasures or alterations must be initialed in ink by the person signing the Bid Form. A Bid price must be indicated for each section, Bid item, alternate, adjustment unit price item, and unit price item listed therein.
- B. If the Bid Form expressly indicates that submitting pricing on a specific alternate item is optional, and Bidder elects to not furnish pricing for such optional alternate item, then Bidder may enter the words "No Bid" or "Not Applicable."
- 12.02 If Bidder has obtained the Bidding Documents as Electronic Documents, then Bidder shall prepare its Bid on a paper copy of the Bid Form printed from the Electronic Documents version of the Bidding Documents. The printed copy of the Bid Form must be clearly legible, printed on 8½ inch by 11-inch paper and as closely identical in appearance to the Electronic Document version of the Bid Form as may be practical. The Owner reserves the right to accept Bid Forms which nominally vary in appearance from the original paper version of the Bid Form, providing that all required information and submittals are included with the Bid.
- 12.03 A Bid by a corporation must be executed in the corporate name by a corporate officer (whose title must appear under the signature), accompanied by evidence of authority to sign. The corporate address and state of incorporation must be shown.
- 12.04 A Bid by a partnership must be executed in the partnership name and signed by a partner (whose title must appear under the signature), accompanied by evidence of authority to sign. The official address of the partnership must be shown.
- 12.05 A Bid by a limited liability company must be executed in the name of the firm by a member or other authorized person and accompanied by evidence of authority to sign. The state of formation of the firm and the official address of the firm must be shown.
- 12.06 A Bid by an individual must show the Bidder's name and official address.
- 12.07 A Bid by a joint venture must be executed by an authorized representative of each joint venturer in the manner indicated on the Bid Form. The joint venture must have been formally established prior to submittal of a Bid, and the official address of the joint venture must be shown.

- 12.08 All names must be printed in ink below the signatures.
- 12.09 The Bid must contain an acknowledgment of receipt of all Addenda, the numbers of which must be filled in on the Bid Form.
- 12.10 Postal and e-mail addresses and telephone number for communications regarding the Bid must be shown.
- 12.11 The Bid must contain evidence of Bidder's authority to do business in the state of Nevada, or Bidder must certify in writing that it will obtain such authority within the time for acceptance of Bids and attach such certification to the Bid.
- 12.12 If Bidder is required to be licensed to submit a Bid or perform the Work in the state of Nevada, the Bid must contain evidence of Bidder's licensure, or Bidder must certify in writing that it will obtain such licensure within the time for acceptance of Bids and attach such certification to the Bid. Bidder's state contractor license number, if any, must also be shown on the Bid Form.

ARTICLE 13—BASIS OF BID

- 13.01 The basis of Bid is set in Section 3 – Bid Form. Description of the various basis of Bid are as follows:
 - A. If Bid is Lump Sum
 - 1. Bidders must submit a Bid on a lump sum basis as set forth in the Bid Form.
 - B. If bid is a Base Bid with Alternates
 - 1. Bidders must submit a Bid on a lump sum basis for the base Bid and include a separate price for each alternate described in the Bidding Documents and as provided for in the Bid Form. The price for each alternate will be the amount added to or deleted from the base Bid if Owner selects the alternate.
 - 2. In the comparison of Bids, alternates will be applied in the same order of priority as listed in the Bid Form.
 - C. If bid is a Unit Price
 - 1. Bidders must submit a Bid on a unit price basis for each item of Work listed in the unit price section of the Bid Form.
 - 2. The "Bid Price" (sometimes referred to as the extended price) for each unit price Bid item will be the product of the "Estimated Quantity," which Owner or its representative has set forth in the Bid Form, for the item and the corresponding "Bid Unit Price" offered by the Bidder. The total of all unit price Bid items will be the sum of these "Bid Prices"; such total will be used by Owner for Bid comparison purposes. The final quantities and Contract Price will be determined in accordance with Paragraph 13.03 of the General Conditions.
 - 3. Discrepancies between the multiplication of units of Work and unit prices will be resolved in favor of the unit prices. Discrepancies between the indicated sum of any column of figures and the correct sum thereof will be resolved in favor of the correct sum.

ARTICLE 14—SUBMITTAL OF BID

- 14.01 The Bid Form is to be completed and submitted to the District's Planet Bids portal on or before the date specified in the Invitation to Bid, together with a copy of the Bid security and any other documents required to be submitted under the terms of Article 2 of the Bid Form.
- 14.02 The original Bid security shall be submitted per Article 8 of these Instructions to Bidders.
- 14.03 The Bidder assumes the sole responsibility for timely delivery of its Bid. Bidders shall allow sufficient time for all bid files to transmit from Bidder's server to the server of the District's bid system. Bid files shall be completely transmitted to IVGID's bid system prior to the time specified or the bid will be rejected by the bid system.

ARTICLE 15—MODIFICATION AND WITHDRAWAL OF BID

- 15.01 An unopened Bid may be withdrawn by an appropriate document duly executed in the same manner that a Bid must be executed and delivered to the place where Bids are to be submitted prior to the date and time for the opening of Bids. Upon receipt of such notice, the unopened Bid will be returned to the Bidder.
- 15.02 If a Bidder wishes to modify its Bid prior to Bid opening, Bidder must withdraw its initial Bid in the manner specified in Paragraph 15.01 and submit a new Bid prior to the date and time for the opening of Bids.
- 15.03 If within 24 hours after Bids are opened any Bidder files a duly signed written notice with Owner and promptly thereafter demonstrates to the reasonable satisfaction of Owner that there was a material and substantial mistake in the preparation of its Bid, the Bidder may withdraw its Bid, and the Bid security will be returned. Thereafter, if the Work is rebid, the Bidder will be disqualified from further bidding on the Work.

ARTICLE 16—OPENING OF BIDS

- 16.01 Bids will be opened at the time and place indicated in the Invitation to Bid and, unless obviously non-responsive, become publicly available. An abstract of the amounts of the base Bids and major alternates, if any, will be made available to Bidders after the opening of Bids.
- 16.02 All Bids will remain subject to acceptance for sixty (60) days after the day of the Bid opening, but Owner may, in its sole discretion, release any Bid and return the Bid security prior to the end of this period.

ARTICLE 17—EVALUATION OF BIDS AND AWARD OF CONTRACT

- 17.01 Owner reserves the right to reject any or all Bids pursuant to Nevada State law, including without limitation, nonconforming, nonresponsive, unbalanced, or conditional Bids. Owner also reserves the right to waive all minor Bid informalities not involving price, time, or changes in the Work.
- 17.02 Owner will reject the Bid of any Bidder that Owner finds, after reasonable inquiry and evaluation, to not be responsible.
- 17.03 If Bidder purports to add terms or conditions to its Bid, takes exception to any provision of the Bidding Documents, or attempts to alter the contents of the Contract Documents for purposes of

the Bid, whether in the Bid itself or in a separate communication to Owner or Engineer, then Owner will reject the Bid as nonresponsive.

17.04 If Owner awards the contract for the Work, such award will be to the responsible Bidder submitting the lowest responsive Bid.

17.05 *Evaluation of Bids*

- A. In evaluating Bids, Owner will consider whether the Bids comply with the prescribed requirements, and such alternates, unit prices, and other data, as may be requested in the Bid Form or prior to the Notice of Award.
- B. If the Unit Bid Item prices and/or schedule of values of a prospective Bidder's Bid are obviously unbalanced, either in excess or below the reasonable cost analysis values, the Bid may be rejected. All bids with separately-priced line items shall be analyzed to determine if the prices are unbalanced. A Bid may be rejected if Owner determines that the lack of balance poses an unacceptable risk to Owner. A Bid with unbalanced pricing may increase performance risk and could result in payment of unreasonably high prices. Unbalanced pricing exists when, despite an acceptable total evaluated price, the price of one or more bid items is significantly over- or understated, as indicated by the application of cost or price analysis techniques. The greatest risks associated with unbalanced pricing occur when:
 - 1. Overpricing of startup work, mobilization, or early items of work ("front-end loading") would cause a Bidder to receive substantial up-front payment;
 - 2. Base quantities and option quantities are separate line items;
 - 3. The quantities as bid are incorrect and the contract cost will be increased when quantities are corrected; and/or
 - 4. On items when the quantities may vary, if the anticipated variation in quantity would result in the lower Bidder not remaining as the low bidder.
- C. More than one Bid for the same Work from an individual or entity under the same or different names will not be considered. Reasonable grounds for believing that any Bidder has an interest in more than one Bid for the Work may be cause for disqualification of that Bidder and the rejection of all Bids in which that Bidder has an interest.
- D. In evaluating bids, Owner will consider whether or not the Bids comply with the prescribed requirements, and such alternates, unit prices and other data as may be requested in the Bid Form or prior to the Notice of Award.
- E. In evaluating whether a Bidder is responsible, Owner will consider the qualifications of the Bidder and may consider the qualifications and experience of Subcontractors and Suppliers proposed for those portions of the Work for which the identity of Subcontractors and Suppliers must be submitted as provided in the Bidding Documents.
- F. Owner may conduct such investigations as Owner deems necessary to establish the responsibility, qualifications, and financial ability of Bidders and any proposed Subcontractors or Suppliers.
- G. If the Contract is to be awarded, Owner will award the Contract to the Bidder whose Bid is in the best interest of the Project.
- H. Owner reserves the right to reduce the Scope of Work up to twenty-five percent (25%) of the total Bid price by deleting items and/or reducing the Scope of Work without invalidating the

Bid, if necessary, to reduce the cost of the project to within the Engineer's Estimate and/or Owner's budget.

- I. Any Bidder which submitted a Bid to Owner may protest the recommendation of award in accordance with procedures as set forth in NRS 338.

ARTICLE 18—BONDS AND INSURANCE

- 18.01 Article 6 of the General Conditions, as may be modified by the Supplementary Conditions, sets forth Owner's requirements as to performance and payment bonds and insurance. When the Successful Bidder delivers the executed Agreement to Owner, it must be accompanied by one (1) copy of each of the required bonds and insurance documentation.
- 18.02 Article 8, Bid Security, of these Instructions, addresses any requirements for providing bid bonds as part of the bidding process.

ARTICLE 19—SIGNING OF AGREEMENT

- 19.01 When Owner issues a Notice of Award to the Successful Bidder, it will be accompanied by the other Contract Documents as identified in the Agreement. Within 10 business days thereafter, Successful Bidder must execute the Agreement and any bonds and insurance documentation required to be delivered by the Contract Documents to Owner. Within 20 business days thereafter, Owner will deliver one fully executed counterpart of the Agreement to Successful Bidder, together with electronic copies of the Contract Documents as stated in Paragraph 2.02 of the General Conditions.

ARTICLE 20—SALES AND USE TAXES

- 20.01 Owner is exempt from Nevada state sales and use taxes on materials and equipment to be incorporated in the Work (Exemption No. 88-760004K). Per Section 15, Chapter 338 of the NRS, each contractor, subcontractor and other person who provides labor, equipment, materials, supplies or services for the Work will comply with the requirements of all applicable state and local laws, including, without limitation, any applicable licensing requirements and requirements for the payment of sales and use taxes on equipment, materials and supplies provided for the Work. Said taxes must not be included in the Bid. Refer to Paragraph SC-7.10 of the Supplementary Conditions for additional information.

ARTICLE 21—NEVADA REVISED STATUTES

- 21.01 Each and every provision of Chapters 332, 338 and 339 of the Nevada Revised Statutes (NRS) and other laws required to be inserted in these Contract Documents shall be deemed to be inserted herein, and the Contract Documents shall be read and enforced as though they are included herein.
- 21.02 In accordance with NRS 338, the Successful Contractor shall report the name and address of each subcontractor to the Owner and Washoe County Labor Commissioner if the estimated total price of the Contract exceeds \$100,000.
- 21.03 Bidder's attention is directed to Chapter 527, Statutes of Nevada 2019, enacted by the Nevada Legislature by passage of Senate Bill 207, an act relating to apprentices, requiring contractor and subcontractors to comply with certain requirements relating to the use of apprentices on public

works projects. *The two lowest responsive bidders will be required to fill out and submit a copy of the project Workforce Checklist, a sample copy of which follows this Section.*

ARTICLE 22—HISTORICAL AND ARCHAEOLOGICAL

22.01 If, during the course of construction, evidence of deposits of historical or archaeological interest is found, the Contractor shall cease operation(s) affecting the find and shall notify the Owner. No further disturbance of the deposits shall ensue until the Owner has notified the Contractor that he may proceed.

ARTICLE 23—SAFETY AND HEALTH REGULATIONS FOR CONSTRUCTION

23.01 These construction documents are to be governed at all times by applicable provisions of the Federal Law, including but not limited to the latest amendment of the following:

- A. Williams-Steiger Occupational Safety and Health Act of 1970, Public Law 94-596
- B. Part 1910 -- Occupational Safety and Health Standards, Chapter XVII of Title 29, Code of Federal Regulations
- C. Part 1926 -- Safety and Health Regulations for Construction, Chapter XVII of Title 29, Code of Federal Regulations.

END OF INSTRUCTIONS

SECTION 3 - BID FORM

The terms used in this Bid with initial capital letters have the meanings stated in the Instructions to Bidders, the General Conditions, and the Supplementary Conditions.

ARTICLE 1—OWNER AND BIDDER

1.01 This Bid is submitted to:

Incline Village General Improvement District
Public Works Department
1220 Sweetwater Road
Incline Village NV 89451
775-832-1267

1.02 The undersigned Bidder proposes and agrees, if this Bid is accepted, to enter into an Agreement with Owner in the form included in the Bidding Documents to perform all Work as specified or indicated in the Bidding Documents for the prices and within the times indicated in this Bid and in accordance with the other terms and conditions of the Bidding Documents.

ARTICLE 2—ATTACHMENTS TO THIS BID

2.01 The following documents are submitted with and made a condition of this Bid:

- A. Required Bid security;
- B. List of Proposed Subcontractors;
- C. List of Proposed Suppliers;
- D. Evidence of authority to do business in the state of Nevada, or a written covenant to obtain such authority within the time for acceptance of Bids;
- E. Contractor's license number as evidence of Bidder's State Contractor's License, or a covenant by Bidder to obtain said license within the time for acceptance of Bids;
- F. Required Bidder Qualification Statement with supporting data; and
- G. **[List other documents and edit above as pertinent].**

ARTICLE 3—BASIS OF BID—LUMP SUM BID AND BID ALTERNATE PRICES

1.01 Bidder will complete the Work in accordance with the Contract Documents for the following Lump Sum price(s):

BASE BID

Description	Total (In Numbers)
SPS #5 Steel Wetwell and Concrete Manhole Rehabilitation	\$ 93,500.00
Total BASE BID In Words: Ninety-three thousand five hundred Dollars and zero cents	

BID ALTERNATE 1

Description	Total (In Numbers)
SPSS Wetwell Bypass Setup & Operation	\$29,500.00
Total BID ALT 1 In Words: Twenty-nine thousand five hundred Dollars and zero cents	

BID ALTERNATE 2

Description	Total (In Numbers)
Concrete Manhole Bypass Setup & Operation	\$ 29,500.00
Total BID ALT 2 In Words: Twenty-nine thousand five hundred Dollars and zero cents	

ARTICLE 4 - TIME OF COMPLETION

- 4.01 Bidder agrees that the Work will be substantially complete and will be completed and ready for final payment in accordance with Paragraph 15.06 of the General Conditions on or before the dates or within the number of calendar days indicated in the Agreement.
- 4.02 Bidder accepts the provisions of the Agreement as to liquidated damages.

ARTICLE 5 - BIDDER'S ACKNOWLEDGEMENTS: ACCEPTANCE PERIOD, INSTRUCTIONS, AND RECEIPT OF ADDENDA

- 5.01 *Bid Acceptance Period*
 - A This Bid will remain subject to acceptance for 60 days after the Bid opening, or for such longer period of time that Bidder may agree to in writing upon request of Owner.
- 5.02 *Instructions to Bidders*
 - A Bidder accepts all of the terms and conditions of the Instructions to Bidders, including without limitation those dealing with the disposition of Bid security.

5.03 *Receipt of Addenda*

- A. Addenda are to be acknowledged through the District's PlanetBids web portal.

ARTICLE 6—BIDDER'S REPRESENTATIONS AND CERTIFICATIONS

6.01 *Bidder's Representations*

- A. In submitting this Bid, Bidder represents the following:
1. Bidder has examined and carefully studied the Bidding Documents, including Addenda.
 2. Bidder has visited the Site, conducted a thorough visual examination of the Site and adjacent areas, and become familiar with the general, local, and Site conditions that may affect cost, progress, and performance of the Work.
 3. Bidder is familiar with all Laws and Regulations that may affect cost, progress, and performance of the Work.
 4. Bidder has carefully studied the reports of explorations and tests of subsurface conditions at or adjacent to the Site and the drawings of physical conditions relating to existing surface or subsurface structures at the Site that have been identified in the Supplementary Conditions, with respect to the Technical Data in such reports and drawings.
 5. Bidder has carefully studied the reports and drawings relating to Hazardous Environmental Conditions, if any, at or adjacent to the Site that have been identified in the Supplementary Conditions, with respect to Technical Data in such reports and drawings.
 6. Bidder has considered the information known to Bidder itself; information commonly known to contractors doing business in the locality of the Site; information and observations obtained from visits to the Site; the Bidding Documents; and the Technical Data identified in the Supplementary Conditions or by definition, with respect to the effect of such information, observations, and Technical Data on (a) the cost, progress, and performance of the Work; (b) the means, methods, techniques, sequences, and procedures of construction to be employed by Bidder, if selected as Contractor; and (c) Bidder's (Contractor's) safety precautions and programs.
 7. Based on the information and observations referred to in the preceding paragraph, Bidder agrees that no further examinations, investigations, explorations, tests, studies, or data are necessary for the performance of the Work at the Contract Price, within the Contract Times, and in accordance with the other terms and conditions of the Contract.
 8. Bidder is aware of the general nature of work to be performed by Owner and others at the Site that relates to the Work as indicated in the Bidding Documents.
 9. Bidder has given Engineer written notice of all conflicts, errors, ambiguities, or discrepancies that Bidder has discovered in the Bidding Documents, and of discrepancies between Site conditions and the Contract Documents, and the written resolution thereof by Engineer is acceptable to Contractor.
 10. The Bidding Documents are generally sufficient to indicate and convey understanding of all terms and conditions for performance and furnishing of the Work.

11. The submission of this Bid constitutes an incontrovertible representation by Bidder that without exception the Bid and all prices in the Bid are premised upon performing and furnishing the Work required by the Bidding Documents.

6.02 *Bidder's Certifications*

A. The Bidder certifies the following:

1. This Bid is genuine and not made in the interest of or on behalf of any undisclosed individual or entity and is not submitted in conformity with any collusive agreement or rules of any group, association, organization, or corporation.
2. Bidder has not directly or indirectly induced or solicited any other Bidder to submit a false or sham Bid.
3. Bidder has not solicited or induced any individual or entity to refrain from bidding.
4. Bidder has not engaged in corrupt, fraudulent, collusive, or coercive practices in competing for the Contract. For the purposes of this Paragraph 8.02.A:
 - a. Corrupt practice means the offering, giving, receiving, or soliciting of anything of value likely to influence the action of a public official in the bidding process.
 - b. Fraudulent practice means an intentional misrepresentation of facts made (a) to influence the bidding process to the detriment of Owner, (b) to establish bid prices at artificial non-competitive levels, or (c) to deprive Owner of the benefits of free and open competition.
 - c. Collusive practice means a scheme or arrangement between two or more Bidders, with or without the knowledge of Owner, a purpose of which is to establish bid prices at artificial, non-competitive levels.
 - d. Coercive practice means harming or threatening to harm, directly or indirectly, persons or their property to influence their participation in the bidding process or affect the execution of the Contract.

BIDDER hereby submits this Bid as set forth above:

Bidder:

Farr Construction Corporation dba. Resource Development Company

(typed or printed name of organization)

By:

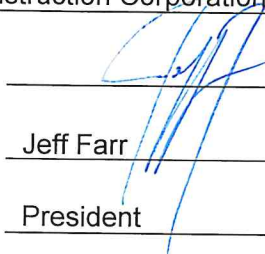

(individual's signature)

Name: Jeff Farr

(typed or printed)

Title: President

(typed or printed)

Date: 5/29/24

(typed or printed)

If Bidder is a corporation, a partnership, or a joint venture, attach evidence of authority to sign.

Attest:

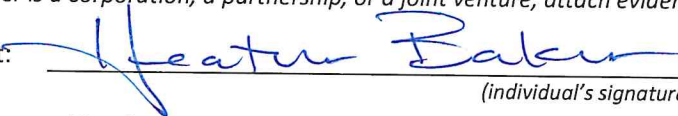

(individual's signature)

Name: Heather Baker

(typed or printed)

Title: Bid Coordinator

(typed or printed)

Date: 5/29/24

(typed or printed)

Address for giving notices:

1050 Linda Way Sparks, NV 89431

Bidder's Contact:

Name: Jeff Farr

(typed or printed)

Title: President

(typed or printed)

Phone: 775-356-8004

Email: jfarr@resourcedevelopmentco.com , hbaker@resourcedevelopmentco.com

Address:

1050 Linda Way

Sparks, NV

89431

Bidder's Contractor License No.: (if applicable) 0075026 A- General Engineering

ADDITIONAL INFORMATION REQUIRED AT BID
Reference Instructions to Bidders Section 2

List five (5) similar projects completed by Contractor within the last 5 years:

Contact Name & Phone No.	Description of Work	Date Complete	Cost
Matt Smith (775) 399-0149 smithm@reno.gov	TMWA-Secondary Clarifier 2A Rehabilitation Project	1/11/2024	\$947,100
	Repair and replacement of joint sealants, installation of steel hardware and preparation for coating of steel		
Carollo Engineering (775) 324-4427	Truckee Donner Public Utility District - Roundhill Tank Rehab Project	8/26/23	\$552,660.00
	300K Tank, weld repairs, interior and exterior coating, burried pipe replacement, new appurtences and acillary items.		
Heidi Baugh (530) 543-6270 hbaugh@stpud.us	STPUD-2023 Flagpole 2 / Iroquois 2 Tanks Recoating Project	10/3/23	\$446,900
	Removing existing coatings on the tanks interiors, preparing the surface, and recoating the interiors of both tanks. The exterior of of one tank was also prepared and overcoated.		
Derek Starkey (775) 784-9918 dstarkey@cityoffernley.org	City of Fernley-US50A-US95A Sanitary Sewer Improvements	6/28/2023	\$341,220.00
	Rehab of Sanitary Sewer Manholes, Installation of a Precast polymer manhole,connection of existing sanitary sewer pipe to new manhole, installing forcemain appurtences , Trenching and Excavation, and Bypass pumping		
Josh Minshall (707) 776-3785 jminshall@cityofpetaluma.org	City of Petaluma - Ellis Creek Channel Coating	3/30/2023	\$244,500
	Repaired the UV treatment channel concrete walls and the Constructing,furnishing, installing, testing and restarting use of the channel for recycled water treatment.		

Work Experience: List years of experience with similar projects, project descriptions, locations and costs, for proposed Job Foreman/ Superintendent:

Forman/Super's Name	Title	Years' Experience	
Jesse Neurenberg	Coating Superintendent	18	
Name & Location of Project City of Fernley-US50A-US95A Sanitary Sewer Improvements Fernley, CA	Description Rehab of Sanitary Sewer Manholes, Install of a Precast polymer manhole,connection of existing sanitary sewer pipe to new manhole, installing forcemain appurtences	Project Cost \$341,220	Date Completed 6/28/2023
Name & Location of Project South Tahoe Public Utility District- 2023 Flagpole 2 / Iroquois 2 Tanks Recoating Project County of El Dorado, California	Description Removing existing coatings on the tanks interiors, preparing the surface, and recoating the interiors of both tanks. The exterior of of one tank was also prepared and overcoated.	Project Cost \$446,900	Date Completed 10/3/23
Name & Location of Project Truckee Donner Public Utility District - Roundhill Tank Rehab Project Roundhill Dr, Truckee, CA 96161	Description 300K Tank, weld repairs, interior and exterior coating, burried pipe replacement, new appurtences and acillary items.	Project Cost \$552,660	Date Completed 8/26/23
Name & Location of Project Truckee Meadows Water Reclamation Facility- Secondary Clarifier 2A Rehab Project Sparks, NV	Description Repair and replacement of joint sealants, installation of steel hardware and preparation for coating of steel	Project Cost \$947,100	Date Completed 1/11/2024

NRS 338.141: List of Subcontractors and Contractor Self Performance Exceeding Five Percent (5%) of Bid Amount

List below the name, address and contractor's or business license number of each first tier subcontractor, equipment or materials supplier who will provide labor, equipment or supplies on the project for which the subcontractor or supplier will be paid an amount exceeding five percent (5%) of the contractor's base bid. For each subcontractor/ supplier listed, also describe the kind of work, equipment or materials the subcontractor/ supplier will provide. (Use an additional sheet, if necessary.)

Prime Contractor's Name, Address & Phone No.	Nevada Contractor License No./License Limit
Farr Construction Corporation dba. Resource Development Company 1050 Linda Way Sparks, NV 89431 775-356-8004	0075026 Unlimited
Kind of Work/Supplies	% of Work/Supplies
Description of work being self-performed by Contractor: All work but what is listed below.	100%

Subcontractor or Supplier Name, Address & Phone No.	Nevada Contractor License No./License Limit
NONE.	
Kind of Work/Supplies	% of Work/Supplies

Subcontractor or Supplier Name, Address & Phone No.	Nevada Contractor License No./License Limit
Kind of Work/Supplies	% of Work/Supplies

Subcontractor or Supplier Name, Address & Phone No.	Nevada Contractor License No./License Limit
Kind of Work/Supplies	% of Work/Supplies

Subcontractor or Supplier Name, Address & Phone No.	Nevada Contractor License No./License Limit
Kind of Work/Supplies	% of Work/Supplies

NRS 338.141: List of Subcontractors and Contractor Self Performance Exceeding One Percent (1%) of Bid Amount or \$50,000, whichever is greater (Two Hour List)

List below the name, address and contractor’s or business license number of each first tier subcontractor, equipment or materials supplier who will provide labor, equipment or supplies on the project for which the subcontractor or supplier will be paid an amount exceeding one percent (1%) of the contractor’s base bid. For each subcontractor/ supplier listed, also describe the kind of work, equipment or materials the subcontractor/ supplier will provide. (Use an additional sheet, if necessary.)

Prime Contractor’s Name, Address & Phone No.	Nevada Contractor License No./License Limit
Farr Construction Corporation dba. Resource Development Company 1050 Linda Way Sparks, NV 89431 775-356-8004	0075026 Unlimited
Kind of Work/Supplies	% of Work/Supplies
Description of work being self-performed by Contractor: All work but what is listed below.	 100%

Subcontractor or Supplier Name, Address & Phone No.	Nevada Contractor License No./License Limit
NONE.	
Kind of Work/Supplies	% of Work/Supplies

Subcontractor or Supplier Name, Address & Phone No.	Nevada Contractor License No./License Limit
Kind of Work/Supplies	% of Work/Supplies

Subcontractor or Supplier Name, Address & Phone No.	Nevada Contractor License No./License Limit
Kind of Work/Supplies	% of Work/Supplies

Subcontractor or Supplier Name, Address & Phone No.	Nevada Contractor License No./License Limit
Kind of Work/Supplies	% of Work/Supplies

PUBLIC WORKS BIDDERS PREFERENCE AFFIDAVIT

I, Jeff Farr, on behalf of Farr Construction Corporation dba. Resource Development Company ("Contractor"), hereby certify and affirm under penalty of perjury, for purposes of qualifying for a preference in bidding under Nevada Revised Statutes Chapter 338 on Project No. 2599DI1104 / PWP WA-2024-055, Project Name SPS #5 Wetwell and Manhole Rehabilitation ("Project"), that the following requirements will be adhered to, documented and attained for the duration of the Project:

1. At least fifty percent (50%) of workers employed on the Project (including Subcontractors) hold a valid driver's license or identification card issued by the Nevada Department of Motor Vehicles;
2. All vehicles used primarily for the Project will be (a) registered and (where applicable) partially apportioned to Nevada; or (b) registered in Nevada;
3. At least fifty percent (50%) of the design professionals who work on the Project (including subcontractors) hold a valid driver's license or identification card issued by the Nevada Department of Motor Vehicles;
4. The Contractor shall maintain and make available for inspection within Nevada all payroll records related to this Project.

Contractor recognizes and accepts that failure to comply with the requirements herein shall be a material breach of the contract and entitle the Incline Village General Improvement District ("Authority") to liquidated damages in the amount set by statute. In addition, the Contractor recognizes and accepts that failure to comply with any requirements herein may lose its certification for preference in bidding for five (5) years and/or the ability to bid on any contracts for public works for one (1) year pursuant to NRS Chapter 338.

Signature: _____

Print Name: Jeff Farr

Title: President Date: 5/29/24

State of Nevada)

)ss.

County of Washoe)

This instrument was acknowledged before me on 29th day of May, 2024, by Jeff Farr (name of person making statement).



Heather Baker
Notary Signature -Heather Baker

NOTARY STAMP

Bid Results

Bidder Details

Vendor Name Farr Construction Corporation dba. Resource Development Company
Address 1050 Linda Way
Sparks, Nevada 89431
United States
Respondee Jeff Farr
Respondee Title President
Phone 775-356-8004
Email hbaker@resourcedevelopmentco.com
Vendor Type
License #

Bid Detail

Bid Format Electronic
Submitted 05/29/2024 2:16 PM (PDT)
Delivery Method
Bid Responsive
Bid Status Submitted
Confirmation # 380658

Respondee Comment

Buyer Comment

Attachments

File Title	File Name	File Type
1. Section 3 - Bid Form, Pages 1 - 9 - FINAL.pdf	1. Section 3 - Bid Form, Pages 1 - 9 - FINAL.pdf	Section 3 - Bid Form, Pages 1 - 9
2. Bid Form Attachments per Article 2 - FINAL.pdf	2. Bid Form Attachments per Article 2 - FINAL.pdf	Bid Form Attachments per Article 2
3. Bid Bond - Executed - FINAL.pdf	3. Bid Bond - Executed - FINAL.pdf	Copy of Bid Bond

Line Items



Discount Terms No Discount

Item #	Item Code	Type	Item Description	UOM	QTY	Unit Price	Line Total	Response	Comment
Section 1							\$93,500.00		
1	1		Section 03 - Base Bid Form	LS	1	\$93,500.00	\$93,500.00	Yes	
Section 2							\$29,500.00		
2	2		Section 03 - Add Alternate #1 (SPS Bypass)	LS	1	\$29,500.00	\$29,500.00	Yes	
Section 3							\$29,500.00		
3			Section 03 - Add Alternate #2 (MH Bypass)	LS	1	\$29,500.00	\$29,500.00	Yes	

Line Item Subtotals

Section Title	Line Total
Section 1	\$93,500.00
Section 2	\$29,500.00
Section 3	\$29,500.00
Grand Total	\$152,500.00

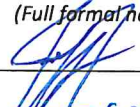
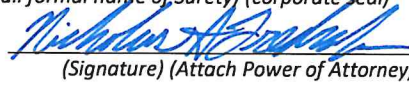
SECTION 4 - BID BOND

Bidder Name: Farr Construction Corporation dba Resource Development Company Address (principal place of business): 1050 Linda Way Sparks, NV 89431	Surety Name: Old Republic Surety Company Address (principal place of business): P.O. Box 1635 Milwaukee, WI 53201
Owner Name: Incline Village GID Address (principal place of business): Public Works Department 1220 Sweetwater Road Incline Village, NV 89451 775-832-1267	Bid Project (name and location): Incline Village GID SPS #5 Wetwell and Manhole Rehabilitation 835 Lakeshore Boulevard Incline Village, NV 89451 Bid Due Date: May 29, 2024
Bond Bond Amount: Five (5%) Percent Of Total Amount Bid (5% Of Total Bid) Date of Bond: May 29, 2024	
Surety and Bidder, intending to be legally bound hereby, subject to the terms set forth in this Bid Bond, do each cause this Bid Bond to be duly executed by an authorized officer, agent, or representative.	
Bidder Farr Construction Corporation dba Resource Development Company <i>(Full formal name of Bidder)</i>	Surety Old Republic Surety Company <i>(Full formal name of Surety) (corporate seal)</i>
By: <u></u> <i>(Signature)</i>	By: <u></u> <i>(Signature) (Attach Power of Attorney)</i>
Name: <u>Jeff Farr</u> <i>(Printed or typed)</i>	Name: <u>Nicholas A. Fredrickson</u> <i>(Printed or typed)</i>
Title: <u>President</u>	Title: <u>Attorney-in-Fact</u>
Attest: <u></u> <i>(Signature)</i>	Attest: <u></u> <i>(Signature)</i>
Name: <u>Heather Baker</u> <i>(Printed or typed)</i>	Name: <u>Andrew Kerslake</u> <i>(Printed or typed)</i>
Title: <u>Witness</u>	Title: <u>Witness</u>
Notes: (1) Note: Addresses are to be used for giving any required notice. (2) Provide execution by any additional parties, such as joint venturers, if necessary.	



1. Bidder and Surety, jointly and severally, bind themselves, their heirs, executors, administrators, successors, and assigns to pay to Owner upon default of Bidder any difference between the total amount of Bidder's Bid and the total amount of the Bid of the next lowest, responsible Bidder that submitted a responsive Bid, as determined by Owner, for the work required by the Contract Documents, provided that:
 - 1.1. If there is no such next Bidder, and Owner does not abandon the Project, then Bidder and Surety shall pay to Owner the bond amount set forth on the face of this Bond, and
 - 1.2. In no event will Bidder's and Surety's obligation hereunder exceed the bond amount set forth on the face of this Bond.
 - 1.3. Recovery under the terms of this Bond will be Owner's sole and exclusive remedy upon default of Bidder.
2. Default of Bidder occurs upon the failure of Bidder to deliver within the time required by the Bidding Documents (or any extension thereof agreed to in writing by Owner) the executed Agreement required by the Bidding Documents and any performance and payment bonds required by the Bidding Documents.
3. This obligation will be null and void if:
 - 3.1. Owner accepts Bidder's Bid and Bidder delivers within the time required by the Bidding Documents (or any extension thereof agreed to in writing by Owner) the executed Agreement required by the Bidding Documents and any performance and payment bonds required by the Bidding Documents, or
 - 3.2. All Bids are rejected by Owner, or
 - 3.3. Owner fails to issue a Notice of Award to Bidder within the time specified in the Bidding Documents (or any extension thereof agreed to in writing by Bidder and, if applicable, consented to by Surety when required by Paragraph 5 hereof).
4. Payment under this Bond will be due and payable upon default of Bidder and within 30 calendar days after receipt by Bidder and Surety of written notice of default from Owner, which notice will be given with reasonable promptness, identifying this Bond and the Project and including a statement of the amount due.
5. Surety waives notice of any and all defenses based on or arising out of any time extension to issue Notice of Award agreed to in writing by Owner and Bidder, provided that the total time for issuing Notice of Award including extensions will not in the aggregate exceed 120 days from Bid due date without Surety's written consent.
6. No suit or action will be commenced under this Bond prior to 30 calendar days after the notice of default required in Paragraph 4 above is received by Bidder and Surety, and in no case later than one year after the Bid due date.
7. Any suit or action under this Bond must be commenced only in a court of competent jurisdiction located in the state in which the Project is located.
8. Notices required hereunder must be in writing and sent to Bidder and Surety at their respective addresses shown on the face of this Bond. Such notices may be sent by personal delivery, commercial courier, or by United States Postal Service registered or certified mail, return receipt requested, postage pre-paid, and will be deemed to be effective upon receipt by the party concerned.
9. Surety shall cause to be attached to this Bond a current and effective Power of Attorney evidencing the authority of the officer, agent, or representative who executed this Bond on behalf of Surety to execute, seal, and deliver such Bond and bind the Surety thereby.
10. This Bond is intended to conform to all applicable statutory requirements. Any applicable requirement of any applicable statute that has been omitted from this Bond will be deemed to be included herein as if set forth at length. If any provision of this Bond conflicts with any applicable statute, then the provision of said statute governs and the remainder of this Bond that is not in conflict therewith continues in full force and effect.
11. The term "Bid" as used herein includes a Bid, offer, or proposal as applicable.



OLD REPUBLIC SURETY COMPANY

POWER OF ATTORNEY

KNOW ALL MEN BY THESE PRESENTS: That OLD REPUBLIC SURETY COMPANY, a Wisconsin stock insurance corporation, does make, constitute and appoint: John R. Claey, Ronald J. Lange, Guy P. Armfield, Scott C. McGilvray, Susan B. Larson, Deanna M. French, Scott Fisher, Elizabeth R. Hahn, Jana M. Roy, Mindee L. Rankin, Roger Kaltenbach, Nicholas A. Fredrickson, Scott A. Garcia, William M. Smith, Charla M. Boadle, Derek D. Sabo, Andrew Kerslake,

Katelyn Cooper, Alec Gumpfer, Gregory C. Ryerson, Andrew P. Larsen of Bellevue, WA its true and lawful Attorney(s)-in-Fact, with full power and authority for and on behalf of the company as surety, to execute and deliver and affix the seal of the company thereto (if a seal is required), bonds, undertakings, recognizances or other written obligations in the nature thereof, (other than bail bonds, bank depository bonds, mortgage deficiency bonds, mortgage guaranty bonds, guarantees of installment paper and note guaranty bonds, self-insurance workers compensation bonds guaranteeing payment of benefits, or black lung bonds), as follows:

ALL WRITTEN INSTRUMENTS

and to bind OLD REPUBLIC SURETY COMPANY thereby, and all of the acts of said Attorneys-in-Fact, pursuant to these presents, are ratified and confirmed. This appointment is made under and by authority of the board of directors at a special meeting held on February 18, 1982.

This Power of Attorney is signed and sealed by facsimile under and by the authority of the following resolutions adopted by the board of directors of the OLD REPUBLIC SURETY COMPANY on February 18, 1982.

RESOLVED that, the president, any vice-president or assistant vice president, in conjunction with the secretary or any assistant secretary, may appoint attorneys-in-fact or agents with authority as defined or limited in the instrument evidencing the appointment in each case, for and on behalf of the company to execute and deliver and affix the seal of the company to bonds, undertakings, recognizances, and suretyship obligations of all kinds; and said officers may remove any such attorney-in-fact or agent and revoke any Power of Attorney previously granted to such person.

RESOLVED FURTHER, that any bond, undertaking, recognizance, or suretyship obligation shall be valid and binding upon the Company

- (i) when signed by the president, any vice president or assistant vice president, and attested and sealed (if a seal be required) by any secretary or assistant secretary; or
- (ii) when signed by the president, any vice president or assistant vice president, secretary or assistant secretary, and countersigned and sealed (if a seal be required) by a duly authorized attorney-in-fact or agent; or
- (iii) when duly executed and sealed (if a seal be required) by one or more attorneys-in-fact or agents pursuant to and within the limits of the authority evidenced by the Power of Attorney issued by the company to such person or persons.

RESOLVED FURTHER that the signature of any authorized officer and the seal of the company may be affixed by facsimile to any Power of Attorney or certification thereof authorizing the execution and delivery of any bond, undertaking, recognizance, or other suretyship obligations of the company; and such signature and seal when so used shall have the same force and effect as though manually affixed.

IN WITNESS WHEREOF, OLD REPUBLIC SURETY COMPANY has caused these presents to be signed by its proper officer, and its corporate seal to be affixed this 4th day of August, 2023.

Karen J. Haffner
Assistant Secretary



OLD REPUBLIC SURETY COMPANY

Alan Pavlic
President

STATE OF WISCONSIN, COUNTY OF WAUKESHA - SS

On this 4th day of August, 2023, personally came before me, Alan Pavlic and Karen J. Haffner, to me known to be the individuals and officers of the OLD REPUBLIC SURETY COMPANY who executed the above instrument, and they each acknowledged the execution of the same, and being by me duly sworn, did severally depose and say: that they are the said officers of the corporation aforesaid, and that the seal affixed to the above instrument is the seal of the corporation, and that said corporate seal and their signatures as such officers were duly affixed and subscribed to the said instrument by the authority of the board of directors of said corporation.



Kathryn R. Pearson
Notary Public

My Commission Expires: September 28, 2026

(Expiration of notary's commission does not invalidate this instrument)

CERTIFICATE

I, the undersigned, assistant secretary of the OLD REPUBLIC SURETY COMPANY, a Wisconsin corporation, CERTIFY that the foregoing and attached Power of Attorney remains in full force and has not been revoked; and furthermore, that the Resolutions of the board of directors set forth in the Power of Attorney, are now in force.

78 8820



Signed and sealed at the City of Brookfield, WI this 29th day of May, 2024.

Karen J. Haffner
Assistant Secretary

ORSC 22262 (3-06)

Parker, Smith & Feek Ins LLC

BARBARA K. CEGAVSKE
Secretary of State

KIMBERLEY PERONDI
Deputy Secretary for
Commercial Recordings

STATE OF NEVADA



OFFICE OF THE
SECRETARY OF STATE

Commercial Recordings Division
202 N. Carson Street
Carson City, NV 89701
Telephone (775) 684-5708
Fax (775) 684-7138
North Las Vegas City Hall
2250 Las Vegas Blvd North, Suite 400
North Las Vegas, NV 89030
Telephone (702) 486-2880
Fax (702) 486-2888

Certified Copy

06/25/2021 14:26:56 PM

Work Order Number: W2021062501371 - 1418133
Reference Number: 20211562836
Through Date: 06/25/2021 14:26:56 PM
Corporate Name: FARR CONSTRUCTION CORPORATION

The undersigned filing officer hereby certifies that the attached copies are true and exact copies of all requested statements and related subsequent documentation filed with the Secretary of State's Office, Commercial Recordings Division listed on the attached report.

Document Number	Description	Number of Pages
00000334560-41	Articles of Incorporation - 08/04/2005	1



Certified By: Electronically Certified
Certificate Number: B202106281785238
You may verify this certificate
online at <http://www.nvsos.gov>

Respectfully,

BARBARA K. CEGAVSKE
Nevada Secretary of State



DEAN HELLER
 Secretary of State
 206 North Carson Street
 Carson City, Nevada 89701-4299
 (775) 684 5708
 Website: secretaryofstate.biz

Articles of Incorporation
 (PURSUANT TO NRS 78)

Filed in the office of <i>Dean Heller</i> Dean Heller Secretary of State State of Nevada	Document Number 00000334560-41
	Filing Date and Time 08/04/2005 7:59 AM
	Entity Number E0538802005-4

Important: Read attached instructions before completing form.

ABOVE SPACE IS FOR OFFICE USE ONLY

1. Name of Corporation:	<u>Fast Construction Corporation</u>
2. Resident Agent Name and Street Address: <small>(must be a Nevada address where process may be served)</small>	Name <u>Jeff Farr</u> Street Address <u>3760 Boulder Ct.</u> <u>Reno</u> <u>NEVADA</u> <u>89507</u> City State Zip Code Optional Mailing Address _____ City State Zip Code
3. Shares: <small>(number of shares corporation authorized to issue)</small>	Number of shares with par value: <u>5,000,000</u> Par value: \$ <u>.001</u> Number of shares without par value: <u>0</u>
4. Names & Addresses of Board of Directors/Trustees: <small>(attach additional page if there is more than 3 directors/trustees)</small>	1. Name <u>Jeff Farr</u> Street Address <u>3760 Boulder Ct</u> <u>Reno</u> <u>NV</u> <u>89507</u> City State Zip Code 2. Name _____ Street Address _____ City State Zip Code 3. Name _____ Street Address _____ City State Zip Code
5. Purpose: <small>(optional - see instructions)</small>	The purpose of this Corporation shall be: <u>Conduct Legal Business</u>
6. Names, Address and Signature of Incorporator: <small>(attach additional page if there is more than 1 incorporator)</small>	Name <u>Jeff Farr</u> Signature <u>[Signature]</u> Address <u>3760 Boulder Ct</u> <u>Reno</u> <u>NV</u> <u>89507</u> City State Zip Code
7. Certificate of Acceptance of Appointment of Resident Agent:	I hereby accept appointment as Resident Agent for the above named corporation. Authorized Signature of R.A. or On Behalf of R.A. Company <u>[Signature]</u> Date <u>04 Aug 2005</u>

This form must be accompanied by appropriate fees. See attached fee schedule.

Nevada Secretary of State Form 78 ARTICLES.2003
 Revised on 11/21/03

STATE CONTRACTORS BOARD

The Nevada State Contractors Board certifies that

FARR CONSTRUCTION CORPORATION dba RESOURCE DEVELOPMENT COMPANY

Licensed since June 28, 2010

License No. **0075026**

Is duly licensed as a contractor in the following classification(s):

PRINCIPALS:

JEFFREY FARR, President, QI
CHRISTOPHER ERB, Vice President

A General Engineering

LIMIT: Unlimited
EXPIRES: 06/30/2024



Chair, Nevada State Contractors Board



SECRETARY OF STATE



NEVADA STATE BUSINESS LICENSE FARR CONSTRUCTION CORPORATION

Nevada Business Identification # NV20051549969

Expiration Date: 08/31/2024

In accordance with Title 7 of Nevada Revised Statutes, pursuant to proper application duly filed and payment of appropriate prescribed fees, the above named is hereby granted a Nevada State Business License for business activities conducted within the State of Nevada.

Valid until the expiration date listed unless suspended, revoked or cancelled in accordance with the provisions in Nevada Revised Statutes. License is not transferable and is not in lieu of any local business license, permit or registration.

License must be cancelled on or before its expiration date if business activity ceases. Failure to do so will result in late fees or penalties which, by law, cannot be waived.



Certificate Number: B202308163882715

You may verify this certificate
online at <http://www.nvsos.gov>

IN WITNESS WHEREOF, I have hereunto set my
hand and affixed the Great Seal of State, at my
office on 08/16/2023.

FRANCISCO V. AGUILAR
Secretary of State



LICENSE NUMBER

W035816A-LIC

LICENSE TYPE

Annual
Active

**THIS CERTIFIES THAT
IN THE NAME OF
LOCATED AT**

**LICENSE - NOT TRANSFERRABLE
POST IN A CONSPICUOUS PLACE**



This license cannot be transferred or assigned. It is valid only for the licensee and location shown below.

RESOURCE DEVELOPMENT COMPANY
Farr Construction Corp
1050 LINDA WAY, SPARKS, NV

RESOURCE DEVELOPMENT COMPANY
Farr Construction Corp
1050 LINDA WAY

SPARKS, NV 89431

This license certifies that the name above has paid the required fees to the license collector of Washoe County and is hereby authorized to conduct business and is subject to the provisions of law.

YEAR LICENSE VALID

Expires on 05/31/2024

LICENSE FEE PAID

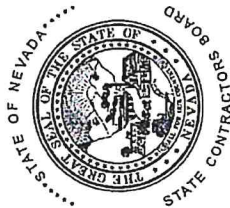

NEVADA STATE CONTRACTORS BOARD

5390 KIETZKE LANE, SUITE 102, RENO, NEVADA, 89511 (775) 688-1141 FAX (775) 688-1271, INVESTIGATIONS (775) 688-1150
8400 WEST SUNSET COURT, SUITE 150, LAS VEGAS, NEVADA, 89113 (702) 486-1100 FAX (702) 486-1190, INVESTIGATIONS (702) 486-1110

CERTIFICATE OF ELIGIBILITY PER NRS 338.147 and NRS 338.1389

CERTIFICATE NUMBER: BPC-11-02-16-0450

FARR CONSTRUCTION CORPORATION DBA RESOURCE DEVELOPMENT COMPANY (HEREIN THE "GENERAL CONTRACTOR") NEVADA STATE CONTRACTORS' LICENSE NUMBER: 0075026 ORIGINAL ISSUE DATE: 06/28/2010 BUSINESS TYPE: **CORPORATION** CLASSIFICATION: **A-GENERAL ENGINEERING** MONETARY LICENSE LIMIT: **UNLIMITED** STATUS: **ACTIVE**, IS HEREBY ISSUED THIS CERTIFICATE BY THE NEVADA STATE CONTRACTORS' BOARD, BASED UPON THE INFORMATION CONTAINED IN THE STATEMENT OF COMPLIANCE WITH NEVADA REVISED STATUTES (NRS) 338.147 AND NRS 338.1389 AND THE AFFIDAVIT OF CERTIFIED PUBLIC ACCOUNTANT SUBMITTED TO THE NEVADA STATE CONTRACTORS BOARD AS PROOF OF CONTRACTOR'S COMPLIANCE WITH THE PROVISIONS OF NRS 338.147 AND NRS 338.1389. IN ACCORDANCE WITH THE PROVISIONS OF NRS 338.147(3), THE ABOVE-NAMED GENERAL CONTRACTOR AND A CERTIFIED PUBLIC ACCOUNTANT HAVE SUBMITTED FULLY EXECUTED AND NOTARIZED SWORN AFFIDAVITS AS PROOF OF PREFERENTIAL BIDDER STATUS, UNDER PENALTY OF PERJURY, CERTIFYING THAT THE GENERAL CONTRACTOR IS QUALIFIED TO RECEIVE A PREFERENCE IN BIDDING AS SET FORTH IN NRS 338.147 AND NRS 338.1389 AND OTHER MATTERS RELATING THERETO.

THIS CERTIFICATE OF ELIGIBILITY IS ISSUED ON JULY 1, 2023 AND EXPIRES ON JUNE 30, 2024, UNLESS SOONER REVOKED OR SUSPENDED BY THE NEVADA STATE CONTRACTORS BOARD.



Susan Broili Kamesch
SUSAN BROILI KAMESCH, LICENSING ADMINISTRATOR DATE 6.27.2023
FOR MARGI A. GREIN, EXECUTIVE OFFICER

The Nevada State Contractors Board assumes no liability or responsibility for the accuracy or validity of the information contained in the Contractors Statement of Compliance or the Affidavit of Certified Public Accountant as Proof of Contractors Compliance with the Provisions of NRS 338.147 and NRS 338.1389. The above-named General Contractor shall bear the responsibility to ascertain the accuracy and validity of the affidavits provided to support the issuance of this certificate.

160 Gamma Drive
Pittsburgh, PA 15238
Tele: 856/616-8222
Fax: 856/616-8228
www.sauereisen.com



May 28, 2024

RE: Farr Construction (dba Resource Development Co): Qualified Applicator

To Whom It May Concern:

This is to certify that Sauereisen has certified and approved Farr Construction (dba Resource Development Co) to apply our materials.

We have confirmed that the personnel of Farr Construction (dba Resource Development Co) are approved in the handling, mixing and application of Sauereisen products. They have demonstrated that they are experienced and qualified to apply all Sauereisen corrosion products.

If there are any questions regarding this matter, please direct them to my attention.

Sincerely,

A handwritten signature in black ink that reads "Scott Wendling". The signature is written in a cursive style.

Scott Wendling
Western Regional Manager
SW/CKK

SECTION 5
AGREEMENT BETWEEN OWNER AND CONTRACTOR
FOR CONSTRUCTION CONTRACT

This Agreement is by and between the **Incline Village General Improvement District** (“Owner” or “IVGID”) and **Farr Construction dba Resource Development Company** (“Contractor”). This Agreement will be effective on **June 27, 2024** (which is the Effective Date of the Contract). Terms used in this Agreement have the meanings stated in the General Conditions and the Supplementary Conditions.

Owner and Contractor hereby agree as follows:

ARTICLE 1—WORK

- 1.01 Contractor shall complete all Work as specified or indicated in the Contract Documents. The Work is generally described as follows: **Rehabilitation of the District’s Sewer Pump Station #5, including lead abatement, recoating both the wetwell and manhole with Sauereisen Sewergard 210X, or approved equal, and installation and operation of a temporary bypass system.**

ARTICLE 2—THE PROJECT

- 2.01 The Project, of which the Work under the Contract Documents is a part, is generally described as follows: **SPS #5 Wetwell and Manhole Rehabilitation.**
- 2.01 IVGID’s Engineering Division is to act as Owner’s representative, assume all duties and responsibilities of Engineer, and have the rights and authority assigned to Engineer in the Contract.
- 2.02 The part of the Project that pertains to the Work has been designed by the IVGID Engineering Division.

ARTICLE 3—CONTRACT TIMES

- 3.01 *Time is of the Essence*
- A. All time limits for Milestones, if any, Substantial Completion, and completion and readiness for final payment as stated in the Contract Documents are of the essence of the Contract.
- B. The OWNER anticipates issuing the Notice to Proceed on or about June 27, 2024.
- 3.02 *Contract Times: Dates*
- A. The Work will be substantially complete on or before **August 23, 2024**, and completed and ready for final payment in accordance with Paragraph 15.06 of the General Conditions on or before **August 30, 2024**.
- 3.03 *Liquidated Damages*
- A. Contractor and Owner recognize that time is of the essence as stated in Paragraph 4.01 above and that Owner will suffer financial and other losses if the Work is not completed and Milestones not achieved within the Contract Times, as duly modified. The parties also recognize the delays, expense, and difficulties involved in proving, in a legal or arbitration proceeding, the actual loss suffered by Owner if the Work is not completed on time.

Accordingly, instead of requiring any such proof, Owner and Contractor agree that as liquidated damages for delay (but not as a penalty):

1. *Substantial Completion:* Contractor shall pay Owner \$500 for each day that expires after the time (as duly adjusted pursuant to the Contract) specified above for Substantial Completion, until the Work is substantially complete.
 2. *Completion of Remaining Work:* After Substantial Completion, if Contractor shall neglect, refuse, or fail to complete the remaining Work within the Contract Times (as duly adjusted pursuant to the Contract) for completion and readiness for final payment, Contractor shall pay Owner \$500 for each day that expires after such time until the Work is completed and ready for final payment.
 4. Liquidated damages for failing to timely attain Substantial Completion, and final completion are not additive, and will not be imposed concurrently.
- B. If Owner recovers liquidated damages for a delay in completion by Contractor, then such liquidated damages are Owner's sole and exclusive remedy for such delay, and Owner is precluded from recovering any other damages, whether actual, direct, excess, or consequential, for such delay, except for special damages (if any) specified in this Agreement.

ARTICLE 4—CONTRACT PRICE

4.01 Owner shall pay Contractor for completion of the Work in accordance with the Contract Documents, the amounts that follow, subject to adjustment under the Contract:

- A. For all Work other than accepted bid-alternate Price Work, a lump sum of **\$93,500**.
All specific cash allowances are included in the above price in accordance with Paragraph 13.02 of the General Conditions.
- B. For all Owner-accepted Bid Alternate Price Work, an amount equal to the sum of the extended prices (established for each separately identified item of Unit Price Work as shown on the Bid Form. The total estimated Contract Price is **\$59,000**.
The extended prices for Unit Price Work set forth as of the Effective Date of the Contract are based on estimated quantities. As provided in Paragraph 13.03 of the General Conditions, estimated quantities are not guaranteed, and determinations of actual quantities and classifications are to be made by Engineer.
- C. For all Work, at the prices stated in Contractor's Bid, attached hereto as an exhibit.

ARTICLE 5—PAYMENT PROCEDURES

5.01 *Submittal and Processing of Payments*

- A. Contractor shall submit Applications for Payment in accordance with Article 15 of the General Conditions. Applications for Payment will be processed by Engineer as provided in the General Conditions. Applications for Payment are to be sent to ap@ivgid.org.

5.02 *Progress Payments; Retainage*

- A. Owner shall make progress payments on the basis of Contractor's Applications for Payment, as recommended by Engineer, on or about the first day of each month during performance of the Work as provided in Paragraph 6.02.A.1 below, provided that such Applications for Payment have been submitted in a timely manner and otherwise meet the requirements of the Contract. All such payments will be measured by the Schedule of Values established as provided in the General Conditions (and in the case of Unit Price Work based on the number of units completed) or, in the event there is no Schedule of Values, as provided elsewhere in the Contract.
 - 1. Prior to Substantial Completion, progress payments will be made in an amount equal to the percentage indicated below but, in each case, less the aggregate of payments previously made and less such amounts as Owner may withhold, including but not limited to liquidated damages, in accordance with the Contract.
 - a. Ninety-five percent (95%) of the value of the Work completed (with the balance being retainage).
 - 1) If 50 percent or more of the Work has been completed, as determined by Engineer, and if the character and progress of the Work have been satisfactory to Owner and Engineer, then as long as the character and progress of the Work remain satisfactory to Owner and Engineer, there will be no additional retainage.
 - b. Upon Substantial Completion, Owner shall pay an amount sufficient to increase total payments to Contractor to ninety-seven and one-half percent (97.5%) of the Work completed, less such amounts set off by Owner pursuant to Paragraph 15.01.E of the General Conditions, and less Engineer's estimate of the value of Work to be completed or corrected as shown on the punch list of items to be completed or corrected prior to final payment.

5.03 *Final Payment*

- A. Upon final completion and acceptance of the Work, and as recommended by Engineer, Owner shall pay the remainder of the Contract Price in accordance with Paragraph 15.06 of the General Conditions.

5.04 *Consent of Surety*

- A. Owner will not make final payment, or return or release retainage at Substantial Completion or any other time, unless Contractor submits written consent of the surety to such payment, return, or release.

5.05 *Interest*

- A. All amounts not paid when due will bear interest at the rate of six percent (6%) per annum.

ARTICLE 6—CONTRACT DOCUMENTS

6.01 *Contents*

- A. The Contract Documents consist of all of the following:
 - 1. This Agreement.
 - 2. Contractor's Bid dated **May 29, 2024**.

3. Bonds:
 - a. Performance bond (together with power of attorney).
 - b. Payment bond (together with power of attorney).
 4. General Conditions.
 5. Supplementary Conditions.
 6. Specifications as listed in the table of contents of the project manual (copy of list attached).
 7. Drawings (not attached but incorporated by reference) consisting of three **(3)** sheets with each sheet bearing the following general title: **SPS #5 Wetwell and Manhole Rehabilitation**
 8. Addenda #1, #2, and #3.
 9. Exhibits to this Agreement (enumerated as follows):
 - a. Documentation submitted by Contractor prior to Notice of Award **May 29, 2024**.
 - b. For all projects over \$100,000, State of Nevada Prevailing Wage Rates, Washoe County, current edition as of Bid Opening date of project.
 10. The following which may be delivered or issued on or after the Effective Date of the Contract and are not attached hereto:
 - a. Notice to Proceed.
 - b. Work Change Directives.
 - c. Change Orders.
- B. The Contract Documents listed in Paragraph 7.01.A are attached to this Agreement (except as expressly noted otherwise above).
- C. There are no Contract Documents other than those listed above in this Article 6.
- D. The Contract Documents may only be amended, modified, or supplemented as provided in the Contract.

ARTICLE 7—REPRESENTATIONS, CERTIFICATIONS, AND STIPULATIONS

7.01 Contractor's Representations

- A. In order to induce Owner to enter into this Contract, Contractor makes the following representations:
1. Contractor has examined and carefully studied the Contract Documents, including Addenda.
 2. Contractor has visited the Site, conducted a thorough visual examination of the Site and adjacent areas, and become familiar with the general, local, and Site conditions that may affect cost, progress, and performance of the Work.
 3. Contractor is familiar with all Laws and Regulations that may affect cost, progress, and performance of the Work.

4. Contractor has carefully studied the reports of explorations and tests of subsurface conditions at or adjacent to the Site and the drawings of physical conditions relating to existing surface or subsurface structures at the Site that have been identified in the Supplementary Conditions, with respect to the Technical Data in such reports and drawings.
5. Contractor has carefully studied the reports and drawings relating to Hazardous Environmental Conditions, if any, at or adjacent to the Site that have been identified in the Supplementary Conditions, with respect to Technical Data in such reports and drawings.
6. Contractor has considered the information known to Contractor itself; information commonly known to contractors doing business in the locality of the Site; information and observations obtained from visits to the Site; the Contract Documents; and the Technical Data identified in the Supplementary Conditions or by definition, with respect to the effect of such information, observations, and Technical Data on (a) the cost, progress, and performance of the Work; (b) the means, methods, techniques, sequences, and procedures of construction to be employed by Contractor; and (c) Contractor's safety precautions and programs.
7. Based on the information and observations referred to in the preceding paragraph, Contractor agrees that no further examinations, investigations, explorations, tests, studies, or data are necessary for the performance of the Work at the Contract Price, within the Contract Times, and in accordance with the other terms and conditions of the Contract.
8. Contractor is aware of the general nature of work to be performed by Owner and others at the Site that relates to the Work as indicated in the Contract Documents.
9. Contractor has given Engineer written notice of all conflicts, errors, ambiguities, or discrepancies that Contractor has discovered in the Contract Documents, and of discrepancies between Site conditions and the Contract Documents, and the written resolution thereof by Engineer is acceptable to Contractor.
10. The Contract Documents are generally sufficient to indicate and convey understanding of all terms and conditions for performance and furnishing of the Work.
11. Contractor's entry into this Contract constitutes an incontrovertible representation by Contractor that without exception all prices in the Agreement are premised upon performing and furnishing the Work required by the Contract Documents.

7.02 *Contractor's Certifications*

- A. Contractor certifies that it has not engaged in corrupt, fraudulent, collusive, or coercive practices in competing for or in executing the Contract. For the purposes of this Paragraph 8.02:
 1. "corrupt practice" means the offering, giving, receiving, or soliciting of anything of value likely to influence the action of a public official in the bidding process or in the Contract execution;
 2. "fraudulent practice" means an intentional misrepresentation of facts made (a) to influence the bidding process or the execution of the Contract to the detriment of Owner,

(b) to establish Bid or Contract prices at artificial non-competitive levels, or (c) to deprive Owner of the benefits of free and open competition;

3. "collusive practice" means a scheme or arrangement between two or more Bidders, with or without the knowledge of Owner, a purpose of which is to establish Bid prices at artificial, non-competitive levels; and
4. "coercive practice" means harming or threatening to harm, directly or indirectly, persons or their property to influence their participation in the bidding process or affect the execution of the Contract.

7.03 *Standard General Conditions*

- A. Owner stipulates that if the General Conditions that are made a part of this Contract are EJCDC® C-700, Standard General Conditions for the Construction Contract (2018), published by the Engineers Joint Contract Documents Committee, and if Owner is the party that has furnished said General Conditions, then Owner has plainly shown all modifications to the standard wording of such published document to the Contractor, in the Supplementary Conditions.

IN WITNESS WHEREOF, Owner and Contractor have signed this Agreement.

OWNER:
INCLINE VILLAGE G. I. D.
Agreed to:

Sara Schmitz, Chair

Date

Michaela Tonking, Secretary

Date

CONTRACTOR:

Agreed to:

By: _____
Signature of Authorized Agent

Print or Type Name and Title

Date

If CONTRACTOR is a Corporation, attach evidence of authority to sign.

Reviewed as to Form:

Sergio Rudin
District Legal Counsel

Date

PERFORMANCE BOND

<p>Contractor</p> <p>Name: Farr Construction Corporation dba Resource Development Company Address (principal place of business): 1050 Linda Way Sparks, NV 89431</p>	<p>Surety</p> <p>Name: Old Republic Surety Company Address (principal place of business): P.O. Box 1635 Milwaukee, WI 53201</p>
<p>Owner</p> <p>Incline Village General Improvement District Mailing address (principal place of business): Public Works Division; 1220 Sweetwater Road; Incline Village, NV 89451</p>	<p>Contract</p> <p>Description (name and location): IVGID SPS #5 Wetwell and Manhole Rehabilitation 835 Lakeshore Boulevard Incline Village, NV 89451 Contract Price: \$152,500.00 Effective Date of Contract: June 27, 2024</p>
<p>Bond</p> <p>Bond Amount: \$152,500.00 (One Hundred Fifty Two Thousand Five Hundred and 00/100 Dollars) Date of Bond: June 27, 2024 (Date of Bond cannot be earlier than Effective Date of Contract) Modifications to this Bond form: <input checked="" type="checkbox"/> None <input type="checkbox"/> See Paragraph 16</p>	
<p>Surety and Contractor, intending to be legally bound hereby, subject to the terms set forth in this Performance Bond, do each cause this Performance Bond to be duly executed by an authorized officer, agent, or representative.</p>	
<p>Contractor as Principal Farr Construction Corporation dba Resource Development Company (Full formal name of Contractor)</p>	<p>Surety Old Republic Surety Company (Full formal name of Surety) (corporate seal)</p>
<p>By: <u>[Signature]</u> (Signature)</p>	<p>By: <u>[Signature]</u> (Signature)(Attach Power of Attorney)</p>
<p>Name: <u>Jeff Farr</u> (Printed or typed)</p>	<p>Name: <u>Roger Kaltenbach</u> (Printed or typed)</p>
<p>Title: <u>President</u></p>	<p>Title: <u>Attorney-in-Fact</u></p>
<p>Attest: <u>[Signature]</u> (Signature)</p>	<p>Attest: <u>[Signature]</u> (Signature)</p>
<p>Name: <u>Heather Baker</u> (Printed or typed)</p>	<p>Name: <u>Nicholas Fredrickson</u> (Printed or typed)</p>
<p>Title: <u>Witness</u></p>	<p>Title: <u>Witness</u></p>
<p>Notes: (1) Provide supplemental execution by any additional parties, such as joint venturers. (2) Any singular reference to Contractor, Surety, Owner, or other party is considered plural where applicable.</p>	

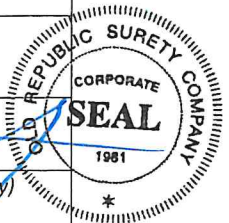

1. The Contractor and Surety, jointly and severally, bind themselves, their heirs, executors, administrators, successors, and assigns to the Owner for the performance of the Construction Contract, which is incorporated herein by reference.
2. If the Contractor performs the Construction Contract, the Surety and the Contractor shall have no obligation under this Bond, except when applicable to participate in a conference as provided in Paragraph 3.
3. If there is no Owner Default under the Construction Contract, the Surety's obligation under this Bond will arise after:
 - 3.1. The Owner first provides notice to the Contractor and the Surety that the Owner is considering declaring a Contractor Default. Such notice may indicate whether the Owner is requesting a conference among the Owner, Contractor, and Surety to discuss the Contractor's performance. If the Owner does not request a conference, the Surety may, within five (5) business days after receipt of the Owner's notice, request such a conference. If the Surety timely requests a conference, the Owner shall attend. Unless the Owner agrees otherwise, any conference requested under this Paragraph 3.1 will be held within ten (10) business days of the Surety's receipt of the Owner's notice. If the Owner, the Contractor, and the Surety agree, the Contractor shall be allowed a reasonable time to perform the Construction Contract, but such an agreement does not waive the Owner's right, if any, subsequently to declare a Contractor Default;
 - 3.2. The Owner declares a Contractor Default, terminates the Construction Contract and notifies the Surety; and
 - 3.3. The Owner has agreed to pay the Balance of the Contract Price in accordance with the terms of the Construction Contract to the Surety or to a contractor selected to perform the Construction Contract.
4. Failure on the part of the Owner to comply with the notice requirement in Paragraph 3.1 does not constitute a failure to comply with a condition precedent to the Surety's obligations, or release the Surety from its obligations, except to the extent the Surety demonstrates actual prejudice.
5. When the Owner has satisfied the conditions of Paragraph 3, the Surety shall promptly and at the Surety's expense take one of the following actions:
 - 5.1. Arrange for the Contractor, with the consent of the Owner, to perform and complete the Construction Contract;
 - 5.2. Undertake to perform and complete the Construction Contract itself, through its agents or independent contractors;
 - 5.3. Obtain bids or negotiated proposals from qualified contractors acceptable to the Owner for a contract for performance and completion of the Construction Contract, arrange for a contract to be prepared for execution by the Owner and a contractor selected with the Owners concurrence, to be secured with performance and payment bonds executed by a qualified surety equivalent to the bonds issued on the Construction Contract, and pay to the Owner the amount of damages as described in Paragraph 7 in excess of the Balance of the Contract Price incurred by the Owner as a result of the Contractor Default; or
 - 5.4. Waive its right to perform and complete, arrange for completion, or obtain a new contractor, and with reasonable promptness under the circumstances:
 - 5.4.1 After investigation, determine the amount for which it may be liable to the Owner and, as soon as practicable after the amount is determined, make payment to the Owner; or
 - 5.4.2 Deny liability in whole or in part and notify the Owner, citing the reasons for denial.
6. If the Surety does not proceed as provided in Paragraph 5 with reasonable promptness, the Surety shall be deemed to be in default on this Bond seven days after receipt of an additional written notice from the Owner to the Surety demanding that the Surety perform its obligations under this Bond, and the Owner shall be entitled to enforce any remedy available to the Owner. If the Surety proceeds as provided in Paragraph 5.4, and the Owner refuses the payment, or the Surety has denied liability, in whole or in part, without further notice, the Owner shall be entitled to enforce any remedy available to the Owner.
7. If the Surety elects to act under Paragraph 5.1, 5.2, or 5.3, then the responsibilities of the Surety to the Owner will not be greater than those of the Contractor under the Construction Contract, and the responsibilities of the Owner

to the Surety will not be greater than those of the Owner under the Construction Contract. Subject to the commitment by the Owner to pay the Balance of the Contract Price, the Surety is obligated, without duplication for:

- 7.1. the responsibilities of the Contractor for correction of defective work and completion of the Construction Contract;
 - 7.2. additional legal, design professional, and delay costs resulting from the Contractor's Default, and resulting from the actions or failure to act of the Surety under Paragraph 5; and
 - 7.3. liquidated damages, or if no liquidated damages are specified in the Construction Contract, actual damages caused by delayed performance or non-performance of the Contractor.
8. If the Surety elects to act under Paragraph 5.1, 5.3, or 5.4, the Surety's liability is limited to the amount of this Bond.
 9. The Surety shall not be liable to the Owner or others for obligations of the Contractor that are unrelated to the Construction Contract, and the Balance of the Contract Price will not be reduced or set off on account of any such unrelated obligations. No right of action will accrue on this Bond to any person or entity other than the Owner or its heirs, executors, administrators, successors, and assigns.
 10. The Surety hereby waives notice of any change, including changes of time, to the Construction Contract or to related subcontracts, purchase orders, and other obligations.
 11. Any proceeding, legal or equitable, under this Bond must be instituted in any court of competent jurisdiction in the location in which the work or part of the work is located and must be instituted within two years after a declaration of Contractor Default or within two years after the Contractor ceased working or within two years after the Surety refuses or fails to perform its obligations under this Bond, whichever occurs first. If the provisions of this paragraph are void or prohibited by law, the minimum periods of limitations available to sureties as a defense in the jurisdiction of the suit will be applicable.
 12. Notice to the Surety, the Owner, or the Contractor must be mailed or delivered to the address shown on the page on which their signature appears.
 13. When this Bond has been furnished to comply with a statutory or other legal requirement in the location where the construction was to be performed, any provision in this Bond conflicting with said statutory or legal requirement will be deemed deleted therefrom and provisions conforming to such statutory or other legal requirement will be deemed incorporated herein. When so furnished, the intent is that this Bond will be construed as a statutory bond and not as a common law bond.
 14. Definitions
 - 14.1. *Balance of the Contract Price*—The total amount payable by the Owner to the Contractor under the Construction Contract after all proper adjustments have been made including allowance for the Contractor for any amounts received or to be received by the Owner in settlement of insurance or other claims for damages to which the Contractor is entitled, reduced by all valid and proper payments made to or on behalf of the Contractor under the Construction Contract.
 - 14.2. *Construction Contract*—The agreement between the Owner and Contractor identified on the cover page, including all Contract Documents and changes made to the agreement and the Contract Documents.
 - 14.3. *Contractor Default*—Failure of the Contractor, which has not been remedied or waived, to perform or otherwise to comply with a material term of the Construction Contract.
 - 14.4. *Owner Default*—Failure of the Owner, which has not been remedied or waived, to pay the Contractor as required under the Construction Contract or to perform and complete or comply with the other material terms of the Construction Contract.
 - 14.5. *Contract Documents*—All the documents that comprise the agreement between the Owner and Contractor.
 15. If this Bond is issued for an agreement between a contractor and subcontractor, the term Contractor in this Bond will be deemed to be Subcontractor and the term Owner will be deemed to be Contractor.
 16. Modifications to this Bond are as follows: **[Describe modification or enter "None"]** NONE



OLD REPUBLIC SURETY COMPANY

POWER OF ATTORNEY

KNOW ALL MEN BY THESE PRESENTS: That OLD REPUBLIC SURETY COMPANY, a Wisconsin stock insurance corporation, does make, constitute and appoint: John R. Claeys, Ronald J. Lange, Guy P. Armfield, Scott C. McGilvray, Susan B. Larson, Deanna M. French, Scott Fisher, Elizabeth R. Hahn, Jana M. Roy, Mindee L. Rankin, Roger Kaltenbach, Nicholas A. Fredrickson, Scott A. Garcia, William M. Smith, Charla M. Boadle, Derek D. Sabo, Andrew Kerslake,

Katelyn Cooper, Alec Gumpfer, Gregory C. Ryerson, Andrew P. Larsen of Bellevue, WA its true and lawful Attorney(s)-in-Fact, with full power and authority for and on behalf of the company as surety, to execute and deliver and affix the seal of the company thereto (if a seal is required), bonds, undertakings, recognizances or other written obligations in the nature thereof, (other than bail bonds, bank depository bonds, mortgage deficiency bonds, mortgage guaranty bonds, guarantees of installment paper and note guaranty bonds, self-insurance workers compensation bonds guaranteeing payment of benefits, or black lung bonds), as follows:

ALL WRITTEN INSTRUMENTS

and to bind OLD REPUBLIC SURETY COMPANY thereby, and all of the acts of said Attorneys-in-Fact, pursuant to these presents, are ratified and confirmed. This appointment is made under and by authority of the board of directors at a special meeting held on February 18, 1982.

This Power of Attorney is signed and sealed by facsimile under and by the authority of the following resolutions adopted by the board of directors of the OLD REPUBLIC SURETY COMPANY on February 18, 1982.

RESOLVED that, the president, any vice-president or assistant vice president, in conjunction with the secretary or any assistant secretary, may appoint attorneys-in-fact or agents with authority as defined or limited in the instrument evidencing the appointment in each case, for and on behalf of the company to execute and deliver and affix the seal of the company to bonds, undertakings, recognizances, and suretyship obligations of all kinds; and said officers may remove any such attorney-in-fact or agent and revoke any Power of Attorney previously granted to such person.

- RESOLVED FURTHER, that any bond, undertaking, recognizance, or suretyship obligation shall be valid and binding upon the Company
- (i) when signed by the president, any vice president or assistant vice president, and attested and sealed (if a seal be required) by any secretary or assistant secretary; or
 - (ii) when signed by the president, any vice president or assistant vice president, secretary or assistant secretary, and countersigned and sealed (if a seal be required) by a duly authorized attorney-in-fact or agent; or
 - (iii) when duly executed and sealed (if a seal be required) by one or more attorneys-in-fact or agents pursuant to and within the limits of the authority evidenced by the Power of Attorney issued by the company to such person or persons.

RESOLVED FURTHER that the signature of any authorized officer and the seal of the company may be affixed by facsimile to any Power of Attorney or certification thereof authorizing the execution and delivery of any bond, undertaking, recognizance, or other suretyship obligations of the company; and such signature and seal when so used shall have the same force and effect as though manually affixed.

IN WITNESS WHEREOF, OLD REPUBLIC SURETY COMPANY has caused these presents to be signed by its proper officer, and its corporate seal to be affixed this 4th day of August, 2023.

Karen J. Haffner
Assistant Secretary



Alan Pavlic
President

STATE OF WISCONSIN, COUNTY OF WAUKESHA - SS

On this 4th day of August, 2023, personally came before me, Alan Pavlic and Karen J Haffner, to me known to be the individuals and officers of the OLD REPUBLIC SURETY COMPANY who executed the above instrument, and they each acknowledged the execution of the same, and being by me duly sworn, did severally depose and say: that they are the said officers of the corporation aforesaid, and that the seal affixed to the above instrument is the seal of the corporation, and that said corporate seal and their signatures as such officers were duly affixed and subscribed to the said instrument by the authority of the board of directors of said corporation.



Kathryn R. Pearson
Notary Public

My Commission Expires: September 28, 2026
(Expiration of notary's commission does not invalidate this instrument)

CERTIFICATE

I, the undersigned, assistant secretary of the OLD REPUBLIC SURETY COMPANY, a Wisconsin corporation, CERTIFY that the foregoing and attached Power of Attorney remains in full force and has not been revoked; and furthermore, that the Resolutions of the board of directors set forth in the Power of Attorney, are now in force.



78 8820
ORSC 22262 (3-06)

Signed and sealed at the City of Brookfield, WI this 27th day of June, 2024.

Karen J. Haffner
Assistant Secretary

SECTION 7 - PAYMENT BOND

<p>Contractor</p> <p>Name: Farr Construction Corporation dba Resource Development Company Address (principal place of business): 1050 Linda Way Sparks, NV 89431</p>	<p>Surety</p> <p>Name: Old Republic Surety Company Address (principal place of business): P.O. Box 1635 Milwaukee, WI 53201</p>
<p>Owner: Incline Village General Improvement District</p> <p>Mailing address (principal place of business): Public Works Department; 1220 Sweetwater Road, Incline Village, NV 89451</p>	<p>Contract</p> <p>Description (name and location): IVGID SPS #5 Wetwell and Manhole Rehabilitation 835 Lakeshore Boulevard Incline Village, NV 89451 Contract Price: \$152,500.00 Effective Date of Contract: June 27, 2024</p>
<p>Bond</p> <p>Bond Amount: \$152,500.00 (One Hundred Fifty Two Thousand Five Hundred and 00/100 Dollars) Date of Bond: June 27, 2024 <i>(Date of Bond cannot be earlier than Effective Date of Contract)</i> Modifications to this Bond form: <input checked="" type="checkbox"/> None <input type="checkbox"/> See Paragraph 18</p>	
<p>Surety and Contractor, intending to be legally bound hereby, subject to the terms set forth in this Payment Bond, do each cause this Payment Bond to be duly executed by an authorized officer, agent, or representative.</p>	
<p>Contractor as Principal Farr Construction Corporation dba Resource Development Company <i>(Full formal name of Contractor)</i></p> <p>By: _____ <i>(Signature)</i></p> <p>Name: <u>Jeff Farr</u> <i>(Printed or typed)</i></p> <p>Title: <u>President</u></p> <p>Attest: <u>Heather Baker</u> <i>(Signature)</i></p> <p>Name: <u>Heather Baker</u> <i>(Printed or typed)</i></p> <p>Title: <u>Witness</u></p>	<p>Surety Old Republic Surety Company <i>(Full formal name of Surety) (corporate seal)</i></p> <p>By: _____ <i>(Signature)(Attach Power of Attorney)</i></p> <p>Name: <u>Roger Kaltenbach</u> <i>(Printed or typed)</i></p> <p>Title: <u>Attorney-in-Fact</u></p> <p>Attest: <u>Nicholas Fredrickson</u> <i>(Signature)</i></p> <p>Name: <u>Nicholas Fredrickson</u> <i>(Printed or typed)</i></p> <p>Title: <u>Witness</u></p>
<p><i>Notes: (1) Provide supplemental execution by any additional parties, such as joint venturers. (2) Any singular reference to Contractor, Surety, Owner, or other party is considered plural where applicable.</i></p>	

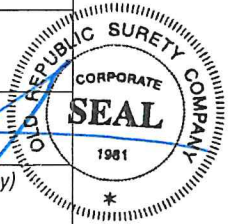

1. The Contractor and Surety, jointly and severally, bind themselves, their heirs, executors, administrators, successors, and assigns to the Owner to pay for labor, materials, and equipment furnished for use in the performance of the Construction Contract, which is incorporated herein by reference, subject to the following terms.
2. If the Contractor promptly makes payment of all sums due to Claimants, and defends, indemnifies, and holds harmless the Owner from claims, demands, liens, or suits by any person or entity seeking payment for labor, materials, or equipment furnished for use in the performance of the Construction Contract, then the Surety and the Contractor shall have no obligation under this Bond.
3. If there is no Owner Default under the Construction Contract, the Surety's obligation to the Owner under this Bond will arise after the Owner has promptly notified the Contractor and the Surety (at the address described in Paragraph 13) of claims, demands, liens, or suits against the Owner or the Owner's property by any person or entity seeking payment for labor, materials, or equipment furnished for use in the performance of the Construction Contract, and tendered defense of such claims, demands, liens, or suits to the Contractor and the Surety.
4. When the Owner has satisfied the conditions in Paragraph 3, the Surety shall promptly and at the Surety's expense defend, indemnify, and hold harmless the Owner against a duly tendered claim, demand, lien, or suit.
5. The Surety's obligations to a Claimant under this Bond will arise after the following:
 - 5.1. Claimants who do not have a direct contract with the Contractor
 - 5.1.1. have furnished a written notice of non-payment to the Contractor, stating with substantial accuracy the amount claimed and the name of the party to whom the materials were, or equipment was, furnished or supplied or for whom the labor was done or performed, within ninety (90) days after having last performed labor or last furnished materials or equipment included in the Claim; and
 - 5.1.2. have sent a Claim to the Surety (at the address described in Paragraph 13).
 - 5.2. Claimants who are employed by or have a direct contract with the Contractor have sent a Claim to the Surety (at the address described in Paragraph 13).
6. If a notice of non-payment required by Paragraph 5.1.1 is given by the Owner to the Contractor, that is sufficient to satisfy a Claimant's obligation to furnish a written notice of non-payment under Paragraph 5.1.1.
7. When a Claimant has satisfied the conditions of Paragraph 5.1 or 5.2, whichever is applicable, the Surety shall promptly and at the Surety's expense take the following actions:
 - 7.1. Send an answer to the Claimant, with a copy to the Owner, within sixty (60) days after receipt of the Claim, stating the amounts that are undisputed and the basis for challenging any amounts that are disputed; and
 - 7.2. Pay or arrange for payment of any undisputed amounts.
 - 7.3. The Surety's failure to discharge its obligations under Paragraph 7.1 or 7.2 will not be deemed to constitute a waiver of defenses the Surety or Contractor may have or acquire as to a Claim, except as to undisputed amounts for which the Surety and Claimant have reached agreement. If, however, the Surety fails to discharge its obligations under Paragraph 7.1 or 7.2, the Surety shall indemnify the Claimant for the reasonable attorney's fees the Claimant incurs thereafter to recover any sums found to be due and owing to the Claimant.
8. The Surety's total obligation will not exceed the amount of this Bond, plus the amount of reasonable attorney's fees provided under Paragraph 7.3, and the amount of this Bond will be credited for any payments made in good faith by the Surety.
9. Amounts owed by the Owner to the Contractor under the Construction Contract will be used for the performance of the Construction Contract and to satisfy claims, if any, under any construction performance bond. By the Contractor furnishing and the Owner accepting this Bond, they agree that all funds earned by the Contractor in the performance of the Construction Contract are dedicated to satisfying obligations of the Contractor and Surety under this Bond, subject to the Owner's priority to use the funds for the completion of the work.
10. The Surety shall not be liable to the Owner, Claimants, or others for obligations of the Contractor that are unrelated to the Construction Contract. The Owner shall not be liable for the payment of any costs or expenses of any Claimant under this Bond, and shall have under this Bond no obligation to make payments to or give notice on behalf of Claimants, or otherwise have any obligations to Claimants under this Bond.
11. The Surety hereby waives notice of any change, including changes of time, to the Construction Contract or to related subcontracts, purchase orders, and other obligations.
12. No suit or action will be commenced by a Claimant under this Bond other than in a court of competent jurisdiction in the state in which the project that is the subject of the Construction Contract is located or after the expiration of one year from the date (1) on which the Claimant sent a Claim to the Surety pursuant to Paragraph 5.1.2 or 5.2, or (2) on which the last labor or service was performed by anyone or the last materials or equipment were furnished by anyone under the Construction Contract,

whichever of (1) or (2) first occurs. If the provisions of this paragraph are void or prohibited by law, the minimum period of limitation available to sureties as a defense in the jurisdiction of the suit will be applicable.

13. Notice and Claims to the Surety, the Owner, or the Contractor must be mailed or delivered to the address shown on the page on which their signature appears. Actual receipt of notice or Claims, however accomplished, will be sufficient compliance as of the date received.
14. When this Bond has been furnished to comply with a statutory or other legal requirement in the location where the construction was to be performed, any provision in this Bond conflicting with said statutory or legal requirement will be deemed deleted here from and provisions conforming to such statutory or other legal requirement will be deemed incorporated herein. When so furnished, the intent is that this Bond will be construed as a statutory bond and not as a common law bond.
15. Upon requests by any person or entity appearing to be a potential beneficiary of this Bond, the Contractor and Owner shall promptly furnish a copy of this Bond or shall permit a copy to be made.
16. Definitions
 - 16.1. *Claim*—A written statement by the Claimant including at a minimum:
 - 16.1.1. The name of the Claimant;
 - 16.1.2. The name of the person for whom the labor was done, or materials or equipment furnished;
 - 16.1.3. A copy of the agreement or purchase order pursuant to which labor, materials, or equipment was furnished for use in the performance of the Construction Contract;
 - 16.1.4. A brief description of the labor, materials, or equipment furnished;
 - 16.1.5. The date on which the Claimant last performed labor or last furnished materials or equipment for use in the performance of the Construction Contract;
 - 16.1.6. The total amount earned by the Claimant for labor, materials, or equipment furnished as of the date of the Claim;
 - 16.1.7. The total amount of previous payments received by the Claimant; and
 - 16.1.8. The total amount due and unpaid to the Claimant for labor, materials, or equipment furnished as of the date of the Claim.
 - 16.2. *Claimant*—An individual or entity having a direct contract with the Contractor or with a subcontractor of the Contractor to furnish labor, materials, or equipment for use in the performance of the Construction Contract. The term Claimant also includes any individual or entity that has rightfully asserted a claim under an applicable mechanic's lien or similar statute against the real property upon which the Project is located. The intent of this Bond is to include without limitation in the terms of "labor, materials, or equipment" that part of the water, gas, power, light, heat, oil, gasoline, telephone service, or rental equipment used in the Construction Contract, architectural and engineering services required for performance of the work of the Contractor and the Contractor's subcontractors, and all other items for which a mechanic's lien may be asserted in the jurisdiction where the labor, materials, or equipment were furnished.
 - 16.3. *Construction Contract*—The agreement between the Owner and Contractor identified on the cover page, including all Contract Documents and all changes made to the agreement and the Contract Documents.
 - 16.4. *Owner Default*—Failure of the Owner, which has not been remedied or waived, to pay the Contractor as required under the Construction Contract or to perform and complete or comply with the other material terms of the Construction Contract.
 - 16.5. *Contract Documents*—All the documents that comprise the agreement between the Owner and Contractor.
17. If this Bond is issued for an agreement between a contractor and subcontractor, the term Contractor in this Bond will be deemed to be Subcontractor and the term Owner will be deemed to be Contractor.
18. Modifications to this Bond are as follows: **[Describe modification or enter "None"] NONE**



OLD REPUBLIC SURETY COMPANY

POWER OF ATTORNEY

KNOW ALL MEN BY THESE PRESENTS: That OLD REPUBLIC SURETY COMPANY, a Wisconsin stock insurance corporation, does make, constitute and appoint: John R. Claeys, Ronald J. Lange, Guy P. Armfield, Scott C. McGilvray, Susan B. Larson, Deanna M. French, Scott Fisher, Elizabeth R. Hahn, Jana M. Roy, Mindee L. Rankin, Roger Kaltenbach, Nicholas A. Fredrickson, Scott A. Garcia, William M. Smith, Charla M. Boadle, Derek D. Sabo, Andrew Kerlake,

Katelyn Cooper, Alec Gumpfer, Gregory C. Ryerson, Andrew P. Larsen of Bellevue, WA its true and lawful Attorney(s)-in-Fact, with full power and authority for and on behalf of the company as surety, to execute and deliver and affix the seal of the company thereto (if a seal is required), bonds, undertakings, recognizances or other written obligations in the nature thereof, (other than bail bonds, bank depository bonds, mortgage deficiency bonds, mortgage guaranty bonds, guarantees of installment paper and note guaranty bonds, self-insurance workers compensation bonds guaranteeing payment of benefits, or black lung bonds), as follows:

ALL WRITTEN INSTRUMENTS

and to bind OLD REPUBLIC SURETY COMPANY thereby, and all of the acts of said Attorneys-in-Fact, pursuant to these presents, are ratified and confirmed. This appointment is made under and by authority of the board of directors at a special meeting held on February 18, 1982.

This Power of Attorney is signed and sealed by facsimile under and by the authority of the following resolutions adopted by the board of directors of the OLD REPUBLIC SURETY COMPANY on February 18, 1982.

RESOLVED that, the president, any vice-president or assistant vice president, in conjunction with the secretary or any assistant secretary, may appoint attorneys-in-fact or agents with authority as defined or limited in the instrument evidencing the appointment in each case, for and on behalf of the company to execute and deliver and affix the seal of the company to bonds, undertakings, recognizances, and suretyship obligations of all kinds; and said officers may remove any such attorney-in-fact or agent and revoke any Power of Attorney previously granted to such person.

RESOLVED FURTHER, that any bond, undertaking, recognizance, or suretyship obligation shall be valid and binding upon the Company

- (i) when signed by the president, any vice president or assistant vice president, and attested and sealed (if a seal be required) by any secretary or assistant secretary; or
- (ii) when signed by the president, any vice president or assistant vice president, secretary or assistant secretary, and countersigned and sealed (if a seal be required) by a duly authorized attorney-in-fact or agent; or
- (iii) when duly executed and sealed (if a seal be required) by one or more attorneys-in-fact or agents pursuant to and within the limits of the authority evidenced by the Power of Attorney issued by the company to such person or persons.

RESOLVED FURTHER that the signature of any authorized officer and the seal of the company may be affixed by facsimile to any Power of Attorney or certification thereof authorizing the execution and delivery of any bond, undertaking, recognizance, or other suretyship obligations of the company; and such signature and seal when so used shall have the same force and effect as though manually affixed.

IN WITNESS WHEREOF, OLD REPUBLIC SURETY COMPANY has caused these presents to be signed by its proper officer, and its corporate seal to be affixed this 4th day of August, 2023.

Karen J. Haffner
Assistant Secretary



OLD REPUBLIC SURETY COMPANY

Alan Pavlic
President

STATE OF WISCONSIN, COUNTY OF WAUKESHA - SS

On this 4th day of August, 2023, personally came before me, Alan Pavlic and Karen J Haffner, to me known to be the individuals and officers of the OLD REPUBLIC SURETY COMPANY who executed the above instrument, and they each acknowledged the execution of the same, and being by me duly sworn, did severally depose and say: that they are the said officers of the corporation aforesaid, and that the seal affixed to the above instrument is the seal of the corporation, and that said corporate seal and their signatures as such officers were duly affixed and subscribed to the said instrument by the authority of the board of directors of said corporation.



Kathryn R. Pearson
Notary Public

My Commission Expires: September 28, 2026
(Expiration of notary's commission does not invalidate this instrument)

CERTIFICATE

I, the undersigned, assistant secretary of the OLD REPUBLIC SURETY COMPANY, a Wisconsin corporation, CERTIFY that the foregoing and attached Power of Attorney remains in full force and has not been revoked; and furthermore, that the Resolutions of the board of directors set forth in the Power of Attorney, are now in force.



78 8820

Signed and sealed at the City of Brookfield, WI this 27th day of June, 2024.

Karen J. Haffner
Assistant Secretary

ORSC 22262 (3-06)

Parker, Smith & Feek Ins LLC

SECTION 6 - APPLICATION AND CERTIFICATION FOR PAYMENT

AIA DOCUMENT G702

PAGE ONE OF

PAGES

TO OWNER:

Incline Village G. I. D., Engineering Dept.
1220 Sweetwater Road, Incline Village, NV
775-832-1267

PROJECT: SPS #5 Wetwell and
Manhole Rehabilitation

APPLICATION NO:

PERIOD TO

Distribution to:

<input type="checkbox"/>	OWNER
<input type="checkbox"/>	ARCHITECT
<input type="checkbox"/>	CONTRACTOR
<input type="checkbox"/>	ENGINEER
<input type="checkbox"/>	

FROM CONTRACTOR:

P.O. Number:

CIP Number: 2299DI1104
PWP WA-2024-055
CONTRACT DATE:

CONTRACTOR'S APPLICATION FOR PAYMENT

Application is made for payment, as shown below, in connection with the Contract. Continuation Sheet, AIA Document G703, is attached.

The undersigned Contractor certifies that to the best of the Contractor's knowledge, information and belief the Work covered by this Application for Payment has been completed in accordance with the Contract Documents, that all amounts have been paid by the Contractor for Work for which previous Certificates for Payment were issued and payments received from the Owner, and that current payment shown herein is now due.

1. ORIGINAL CONTRACT SUM	\$	0.00
2. Net change by Change Orders	\$	0.00
3. CONTRACT SUM TO DATE (Line 1 ± 2)	\$	0.00
4. TOTAL COMPLETED & STORED TO DATE (Column G on G703)	\$	0.00
5. RETAINAGE:		
a. 5 % of Completed Work (Column D + E on G703)	\$	0.00
b. % of Stored Material (Column F on G703)	\$	
Total Retainage (Lines 5a + 5b or Total in Column I of G703)	\$	0.00
6. TOTAL EARNED LESS RETAINAGE (Line 4 Less Line 5 Total)	\$	0.00
7. LESS PREVIOUS CERTIFICATES FOR PAYMENT (Line 6 from prior Certificate)	\$	
8. CURRENT PAYMENT DUE	\$	0.00
9. BALANCE TO FINISH, INCL. RETAINAGE (Line 3 less Line 6)	\$	0.00

CONTRACTOR:

By: _____ Date: _____

State of: _____ County of: _____
Subscribed and sworn to before me this _____ day of _____
Notary Public:
My Commission expires:

ENGINEER'S CERTIFICATE FOR PAYMENT

In accordance with the Contract Documents, based on on-site observations and the data comprising the application, the Engineer certifies to the Owner that to the best of the Engineer's knowledge, information and belief the Work has progressed as indicated, the quality of the Work is in accordance with the Contract Documents, and the Contractor is entitled to payment of the AMOUNT CERTIFIED.

AMOUNT CERTIFIED \$ **0.00**

(Attach explanation if amount certified differs from the amount applied. Initial all figures on this Application and on the Continuation Sheet that are changed to conform with the amount certified.)

OWNER:

By: _____ Date: _____

This Certificate is not negotiable. The AMOUNT CERTIFIED is payable only to the Contractor named herein. Issuance, payment and acceptance of payment are without prejudice to any rights of the Owner or Contractor under this Contract.

CHANGE ORDER SUMMARY	ADDITIONS	DEDUCTIONS
Total changes approved in previous months by OWNER:	\$0.00	\$0.00
Total approved this Month:	\$0.00	\$0.00
TOTALS:	\$0.00	\$0.00
NET CHANGES by Change Order:	\$0.00	

Section 6 - Page 1

SECTION 9 - GENERAL CONDITIONS OF THE CONSTRUCTION CONTRACT

TABLE OF CONTENTS

	Page
Article 1—Definitions and Terminology.....	1
1.01 Defined Terms.....	1
1.02 Terminology	6
Article 2—Preliminary Matters.....	7
2.01 Delivery of Performance and Payment Bonds; Evidence of Insurance.....	7
2.02 Copies of Documents	7
2.03 Before Starting Construction	7
2.04 Preconstruction Conference; Designation of Authorized Representatives.....	8
2.05 Acceptance of Schedules	8
2.06 Electronic Transmittals	8
Article 3—Contract Documents: Intent, Requirements, Reuse.....	9
3.01 Intent.....	9
3.02 Reference Standards.....	9
3.03 Reporting and Resolving Discrepancies	10
3.04 Requirements of the Contract Documents.....	10
3.05 Reuse of Documents	11
Article 4—Commencement and Progress of the Work	11
4.01 Commencement of Contract Times; Notice to Proceed.....	11
4.02 Starting the Work.....	11
4.03 Reference Points	12
4.04 Progress Schedule.....	12
4.05 Delays in Contractor’s Progress	12
Article 5—Site; Subsurface and Physical Conditions; Hazardous Environmental Conditions	14
5.01 Availability of Lands	14
5.02 Use of Site and Other Areas.....	14
5.03 Subsurface and Physical Conditions.....	15
5.04 Differing Subsurface or Physical Conditions	16

5.05	Underground Facilities.....	18
5.06	Hazardous Environmental Conditions at Site	19
Article 6—Bonds and Insurance.....		22
6.01	Performance, Payment, and Other Bonds.....	22
6.02	Insurance—General Provisions.....	22
6.03	Contractor’s Insurance.....	24
6.04	Builder’s Risk and Other Property Insurance.....	25
6.05	Property Losses; Subrogation	26
6.06	Receipt and Application of Property Insurance Proceeds	27
Article 7—Contractor’s Responsibilities		28
7.01	Contractor’s Means and Methods of Construction	28
7.02	Supervision and Superintendence	28
7.03	Labor; Working Hours	28
7.04	Services, Materials, and Equipment	28
7.05	“Or Equals”.....	29
7.06	Substitutes	30
7.07	Concerning Subcontractors and Suppliers.....	31
7.08	Patent Fees and Royalties.....	33
7.09	Permits	33
7.10	Taxes	34
7.11	Laws and Regulations.....	34
7.12	Record Documents.....	34
7.13	Safety and Protection	34
7.14	Hazard Communication Programs	36
7.15	Emergencies.....	36
7.16	Submittals	36
7.17	Contractor’s General Warranty and Guarantee	39
7.18	Indemnification	40
7.19	Delegation of Professional Design Services	40
Article 8—Other Work at the Site.....		41
8.01	Other Work	41
8.02	Coordination	42
8.03	Legal Relationships.....	42

Article 9—Owner’s Responsibilities	43
9.01 Communications to Contractor	43
9.02 Replacement of Engineer	43
9.03 Furnish Data	43
9.04 Pay When Due.....	43
9.05 Lands and Easements; Reports, Tests, and Drawings.....	44
9.06 Insurance.....	44
9.07 Change Orders	44
9.08 Inspections, Tests, and Approvals.....	44
9.09 Limitations on Owner’s Responsibilities	44
9.10 Undisclosed Hazardous Environmental Condition.....	44
9.11 Evidence of Financial Arrangements.....	44
9.12 Safety Programs	44
Article 10—Engineer’s Status During Construction	45
10.01 Owner’s Representative.....	45
10.02 Visits to Site.....	45
10.03 Resident Project Representative.....	45
10.04 Engineer’s Authority	45
10.05 Determinations for Unit Price Work	46
10.06 Decisions on Requirements of Contract Documents and Acceptability of Work	46
10.07 Limitations on Engineer’s Authority and Responsibilities	46
10.08 Compliance with Safety Program.....	46
Article 11—Changes to the Contract	47
11.01 Amending and Supplementing the Contract	47
11.02 Change Orders	47
11.03 Work Change Directives.....	47
11.04 Field Orders.....	48
11.05 Owner-Authorized Changes in the Work	48
11.06 Unauthorized Changes in the Work.....	48
11.07 Change of Contract Price	48
11.08 Change of Contract Times.....	50
11.09 Change Proposals.....	50
11.10 Notification to Surety.....	51

Article 12—Claims.....	51
12.01 Claims.....	51
Article 13—Cost of the Work; Allowances; Unit Price Work	53
13.01 Cost of the Work	53
13.02 Allowances	56
13.03 Unit Price Work.....	56
Article 14—Tests and Inspections; Correction, Removal, or Acceptance of Defective Work	57
14.01 Access to Work.....	57
14.02 Tests, Inspections, and Approvals.....	57
14.03 Defective Work	58
14.04 Acceptance of Defective Work.....	59
14.05 Uncovering Work	59
14.06 Owner May Stop the Work	60
14.07 Owner May Correct Defective Work.....	60
Article 15—Payments to Contractor; Set-Offs; Completion; Correction Period	60
15.01 Progress Payments.....	60
15.02 Contractor’s Warranty of Title	64
15.03 Substantial Completion.....	64
15.04 Partial Use or Occupancy	65
15.05 Final Inspection	65
15.06 Final Payment.....	65
15.07 Waiver of Claims	67
15.08 Correction Period	67
Article 16—Suspension of Work and Termination	68
16.01 Owner May Suspend Work	68
16.02 Owner May Terminate for Cause.....	68
16.03 Owner May Terminate for Convenience.....	69
16.04 Contractor May Stop Work or Terminate	69
Article 17—Final Resolution of Disputes	70
17.01 Methods and Procedures.....	70
Article 18—Miscellaneous	70
18.01 Giving Notice	70
18.02 Computation of Times.....	71

18.03	Cumulative Remedies	71
18.04	Limitation of Damages	71
18.05	No Waiver	71
18.06	Survival of Obligations	71
18.07	Controlling Law	71
18.08	Assignment of Contract.....	71
18.09	Successors and Assigns	72
18.10	Headings.....	72

STANDARD GENERAL CONDITIONS OF THE CONSTRUCTION CONTRACT

ARTICLE 1—DEFINITIONS AND TERMINOLOGY

1.01 *Defined Terms*

- A. Wherever used in the Bidding Requirements or Contract Documents, a term printed with initial capital letters, including the term's singular and plural forms, will have the meaning indicated in the definitions below. In addition to terms specifically defined, terms with initial capital letters in the Contract Documents include references to identified articles and paragraphs, and the titles of other documents or forms.
1. *Addenda*—Written or graphic instruments issued prior to the opening of Bids which clarify, correct, or change the Bidding Requirements or the proposed Contract Documents.
 2. *Agreement*—The written instrument, executed by Owner and Contractor, that sets forth the Contract Price and Contract Times, identifies the parties and the Engineer, and designates the specific items that are Contract Documents.
 3. *Application for Payment*—The document prepared by Contractor, in a form acceptable to Engineer, to request progress or final payments, and which is to be accompanied by such supporting documentation as is required by the Contract Documents.
 4. *Bid*—The offer of a Bidder submitted on the prescribed form setting forth the prices for the Work to be performed.
 5. *Bidder*—An individual or entity that submits a Bid to Owner.
 6. *Bidding Documents*—The Bidding Requirements, the proposed Contract Documents, and all Addenda.
 7. *Bidding Requirements*—The Advertisement or invitation to bid, Instructions to Bidders, Bid Bond or other Bid security, if any, the Bid Form, and the Bid with any attachments.
 8. *Change Order*—A document which is signed by Contractor and Owner and authorizes an addition, deletion, or revision in the Work or an adjustment in the Contract Price or the Contract Times, or other revision to the Contract, issued on or after the Effective Date of the Contract.
 9. *Change Proposal*—A written request by Contractor, duly submitted in compliance with the procedural requirements set forth herein, seeking an adjustment in Contract Price or Contract Times; contesting an initial decision by Engineer concerning the requirements of the Contract Documents or the acceptability of Work under the Contract Documents; challenging a set-off against payments due; or seeking other relief with respect to the terms of the Contract.
 10. *Claim*
 - a. A demand or assertion by Owner directly to Contractor, duly submitted in compliance with the procedural requirements set forth herein, seeking an adjustment of Contract Price or Contract Times; contesting an initial decision by Engineer concerning the

- requirements of the Contract Documents or the acceptability of Work under the Contract Documents; contesting Engineer's decision regarding a Change Proposal; seeking resolution of a contractual issue that Engineer has declined to address; or seeking other relief with respect to the terms of the Contract.
- b. A demand or assertion by Contractor directly to Owner, duly submitted in compliance with the procedural requirements set forth herein, contesting Engineer's decision regarding a Change Proposal, or seeking resolution of a contractual issue that Engineer has declined to address.
 - c. A demand or assertion by Owner or Contractor, duly submitted in compliance with the procedural requirements set forth herein, made pursuant to Paragraph 12.01.A.4, concerning disputes arising after Engineer has issued a recommendation of final payment.
 - d. A demand for money or services by a third party is not a Claim.
11. *Constituent of Concern*—Asbestos, petroleum, radioactive materials, polychlorinated biphenyls (PCBs), lead-based paint (as defined by the HUD/EPA standard), hazardous waste, and any substance, product, waste, or other material of any nature whatsoever that is or becomes listed, regulated, or addressed pursuant to Laws and Regulations regulating, relating to, or imposing liability or standards of conduct concerning, any hazardous, toxic, or dangerous waste, substance, or material.
 12. *Contract*—The entire and integrated written contract between Owner and Contractor concerning the Work.
 13. *Contract Documents*—Those items so designated in the Agreement, and which together comprise the Contract.
 14. *Contract Price*—The money that Owner has agreed to pay Contractor for completion of the Work in accordance with the Contract Documents.
 15. *Contract Times*—The number of days or the dates by which Contractor shall: (a) achieve Milestones, if any; (b) achieve Substantial Completion; and (c) complete the Work.
 16. *Contractor*—The individual or entity with which Owner has contracted for performance of the Work.
 17. *Cost of the Work*—See Paragraph 13.01 for definition.
 18. *Drawings*—The part of the Contract that graphically shows the scope, extent, and character of the Work to be performed by Contractor.
 19. *Effective Date of the Contract*—The date, indicated in the Agreement, on which the Contract becomes effective.
 20. *Electronic Document*—Any Project-related correspondence, attachments to correspondence, data, documents, drawings, information, or graphics, including but not limited to Shop Drawings and other Submittals, that are in an electronic or digital format.
 21. *Electronic Means*—Electronic mail (email), upload/download from a secure Project website, or other communications methods that allow: (a) the transmission or communication of Electronic Documents; (b) the documentation of transmissions, including sending and receipt; (c) printing of the transmitted Electronic Document by the

recipient; (d) the storage and archiving of the Electronic Document by sender and recipient; and (e) the use by recipient of the Electronic Document for purposes permitted by this Contract. Electronic Means does not include the use of text messaging, or of Facebook, Twitter, Instagram, or similar social media services for transmission of Electronic Documents.

22. *Engineer*—The individual or entity named as such in the Agreement.
23. *Field Order*—A written order issued by Engineer which requires minor changes in the Work but does not change the Contract Price or the Contract Times.
24. *Hazardous Environmental Condition*—The presence at the Site of Constituents of Concern in such quantities or circumstances that may present a danger to persons or property exposed thereto.
 - a. The presence at the Site of materials that are necessary for the execution of the Work, or that are to be incorporated into the Work, and that are controlled and contained pursuant to industry practices, Laws and Regulations, and the requirements of the Contract, is not a Hazardous Environmental Condition.
 - b. The presence of Constituents of Concern that are to be removed or remediated as part of the Work is not a Hazardous Environmental Condition.
 - c. The presence of Constituents of Concern as part of the routine, anticipated, and obvious working conditions at the Site, is not a Hazardous Environmental Condition.
25. *Laws and Regulations; Laws or Regulations*—Any and all applicable laws, statutes, rules, regulations, ordinances, codes, and binding decrees, resolutions, and orders of any and all governmental bodies, agencies, authorities, and courts having jurisdiction.
26. *Liens*—Charges, security interests, or encumbrances upon Contract-related funds, real property, or personal property.
27. *Milestone*—A principal event in the performance of the Work that the Contract requires Contractor to achieve by an intermediate completion date, or by a time prior to Substantial Completion of all the Work.
28. *Notice of Award*—The written notice by Owner to a Bidder of Owner's acceptance of the Bid.
29. *Notice to Proceed*—A written notice by Owner to Contractor fixing the date on which the Contract Times will commence to run and on which Contractor shall start to perform the Work.
30. *Owner*—The individual or entity with which Contractor has contracted regarding the Work, and which has agreed to pay Contractor for the performance of the Work, pursuant to the terms of the Contract.
31. *Progress Schedule*—A schedule, prepared and maintained by Contractor, describing the sequence and duration of the activities comprising Contractor's plan to accomplish the Work within the Contract Times.
32. *Project*—The total undertaking to be accomplished for Owner by engineers, contractors, and others, including planning, study, design, construction, testing, commissioning, and start-up, and of which the Work to be performed under the Contract Documents is a part.

33. *Resident Project Representative*—The authorized representative of Engineer assigned to assist Engineer at the Site. As used herein, the term Resident Project Representative (RPR) includes any assistants or field staff of Resident Project Representative.
34. *Samples*—Physical examples of materials, equipment, or workmanship that are representative of some portion of the Work and that establish the standards by which such portion of the Work will be judged.
35. *Schedule of Submittals*—A schedule, prepared and maintained by Contractor, of required submittals and the time requirements for Engineer’s review of the submittals.
36. *Schedule of Values*—A schedule, prepared and maintained by Contractor, allocating portions of the Contract Price to various portions of the Work and used as the basis for reviewing Contractor’s Applications for Payment.
37. *Shop Drawings*—All drawings, diagrams, illustrations, schedules, and other data or information that are specifically prepared or assembled by or for Contractor and submitted by Contractor to illustrate some portion of the Work. Shop Drawings, whether approved or not, are not Drawings and are not Contract Documents.
38. *Site*—Lands or areas indicated in the Contract Documents as being furnished by Owner upon which the Work is to be performed, including rights-of-way and easements, and such other lands or areas furnished by Owner which are designated for the use of Contractor.

See SC-1.01

39. *Specifications*—The part of the Contract that consists of written requirements for materials, equipment, systems, standards, and workmanship as applied to the Work, and certain administrative requirements and procedural matters applicable to the Work.
40. *Subcontractor*—An individual or entity having a direct contract with Contractor or with any other Subcontractor for the performance of a part of the Work.
41. *Submittal*—A written or graphic document, prepared by or for Contractor, which the Contract Documents require Contractor to submit to Engineer, or that is indicated as a Submittal in the Schedule of Submittals accepted by Engineer. Submittals may include Shop Drawings and Samples; schedules; product data; Owner-delegated designs; sustainable design information; information on special procedures; testing plans; results of tests and evaluations, source quality-control testing and inspections, and field or Site quality-control testing and inspections; warranties and certifications; Suppliers’ instructions and reports; records of delivery of spare parts and tools; operations and maintenance data; Project photographic documentation; record documents; and other such documents required by the Contract Documents. Submittals, whether or not approved or accepted by Engineer, are not Contract Documents. Change Proposals, Change Orders, Claims, notices, Applications for Payment, and requests for interpretation or clarification are not Submittals.
42. *Substantial Completion*—The time at which the Work (or a specified part thereof) has progressed to the point where, in the opinion of Engineer, the Work (or a specified part thereof) is sufficiently complete, in accordance with the Contract Documents, so that the Work (or a specified part thereof) can be utilized for the purposes for which it is intended.

The terms “substantially complete” and “substantially completed” as applied to all or part of the Work refer to Substantial Completion of such Work.

43. *Successful Bidder*—The Bidder to which the Owner makes an award of contract.
44. *Supplementary Conditions*—The part of the Contract that amends or supplements these General Conditions.
45. *Supplier*—A manufacturer, fabricator, supplier, distributor, or vendor having a direct contract with Contractor or with any Subcontractor to furnish materials or equipment to be incorporated in the Work by Contractor or a Subcontractor.
46. *Technical Data*
- a. Those items expressly identified as Technical Data in the Supplementary Conditions, with respect to either (1) existing subsurface conditions at or adjacent to the Site, or existing physical conditions at or adjacent to the Site including existing surface or subsurface structures (except Underground Facilities) or (2) Hazardous Environmental Conditions at the Site.
 - b. If no such express identifications of Technical Data have been made with respect to conditions at the Site, then Technical Data is defined, with respect to conditions at the Site under Paragraphs 5.03, 5.04, and 5.06, as the data contained in boring logs, recorded measurements of subsurface water levels, assessments of the condition of subsurface facilities, laboratory test results, and other factual, objective information regarding conditions at the Site that are set forth in any geotechnical, environmental, or other Site or facilities conditions report prepared for the Project and made available to Contractor.
 - c. Information and data regarding the presence or location of Underground Facilities are not intended to be categorized, identified, or defined as Technical Data, and instead Underground Facilities are shown or indicated on the Drawings.
47. *Underground Facilities*—All active or not-in-service underground lines, pipelines, conduits, ducts, encasements, cables, wires, manholes, vaults, tanks, tunnels, or other such facilities or systems at the Site, including but not limited to those facilities or systems that produce, transmit, distribute, or convey telephone or other communications, cable television, fiber optic transmissions, power, electricity, light, heat, gases, oil, crude oil products, liquid petroleum products, water, steam, waste, wastewater, storm water, other liquids or chemicals, or traffic or other control systems. An abandoned facility or system is not an Underground Facility.
48. *Unit Price Work*—Work to be paid for on the basis of unit prices.
49. *Work*—The entire construction or the various separately identifiable parts thereof required to be provided under the Contract Documents. Work includes and is the result of performing or providing all labor, services, and documentation necessary to produce such construction; furnishing, installing, and incorporating all materials and equipment into such construction; and may include related services such as testing, start-up, and commissioning, all as required by the Contract Documents.
50. *Work Change Directive*—A written directive to Contractor issued on or after the Effective Date of the Contract, signed by Owner and recommended by Engineer, ordering an addition, deletion, or revision in the Work.

1.02 Terminology

- A. The words and terms discussed in Paragraphs 1.02.B, C, D, and E are not defined terms that require initial capital letters, but, when used in the Bidding Requirements or Contract Documents, have the indicated meaning.
- B. *Intent of Certain Terms or Adjectives:* The Contract Documents include the terms “as allowed,” “as approved,” “as ordered,” “as directed” or terms of like effect or import to authorize an exercise of professional judgment by Engineer. In addition, the adjectives “reasonable,” “suitable,” “acceptable,” “proper,” “satisfactory,” or adjectives of like effect or import are used to describe an action or determination of Engineer as to the Work. It is intended that such exercise of professional judgment, action, or determination will be solely to evaluate, in general, the Work for compliance with the information in the Contract Documents and with the design concept of the Project as a functioning whole as shown or indicated in the Contract Documents (unless there is a specific statement indicating otherwise). The use of any such term or adjective is not intended to and shall not be effective to assign to Engineer any duty or authority to supervise or direct the performance of the Work, or any duty or authority to undertake responsibility contrary to the provisions of Article 10 or any other provision of the Contract Documents.
- C. *Day:* The word “day” means a calendar day of 24 hours measured from midnight to the next midnight.
- D. *Defective:* The word “defective,” when modifying the word “Work,” refers to Work that is unsatisfactory, faulty, or deficient in that it:
1. does not conform to the Contract Documents;
 2. does not meet the requirements of any applicable inspection, reference standard, test, or approval referred to in the Contract Documents; or
 3. has been damaged prior to Engineer’s recommendation of final payment (unless responsibility for the protection thereof has been assumed by Owner at Substantial Completion in accordance with Paragraph 15.03 or Paragraph 15.04).
- E. *Furnish, Install, Perform, Provide*
1. The word “furnish,” when used in connection with services, materials, or equipment, means to supply and deliver said services, materials, or equipment to the Site (or some other specified location) ready for use or installation and in usable or operable condition.
 2. The word “install,” when used in connection with services, materials, or equipment, means to put into use or place in final position said services, materials, or equipment complete and ready for intended use.
 3. The words “perform” or “provide,” when used in connection with services, materials, or equipment, means to furnish and install said services, materials, or equipment complete and ready for intended use.
 4. If the Contract Documents establish an obligation of Contractor with respect to specific services, materials, or equipment, but do not expressly use any of the four words “furnish,” “install,” “perform,” or “provide,” then Contractor shall furnish and install said services, materials, or equipment complete and ready for intended use.

- F. *Contract Price or Contract Times*: References to a change in “Contract Price or Contract Times” or “Contract Times or Contract Price” or similar, indicate that such change applies to (1) Contract Price, (2) Contract Times, or (3) both Contract Price and Contract Times, as warranted, even if the term “or both” is not expressed.
- G. Unless stated otherwise in the Contract Documents, words or phrases that have a well-known technical or construction industry or trade meaning are used in the Contract Documents in accordance with such recognized meaning.

ARTICLE 2—PRELIMINARY MATTERS

2.01 *Delivery of Performance and Payment Bonds; Evidence of Insurance*

- A. *Performance and Payment Bonds*: When Contractor delivers the signed counterparts of the Agreement to Owner, Contractor shall also deliver to Owner the performance bond and payment bond (if the Contract requires Contractor to furnish such bonds).
- B. ~~*Evidence of Contractor’s Insurance*: When Contractor delivers the signed counterparts of the Agreement to Owner, Contractor shall also deliver to Owner, with copies to each additional insured (as identified in the Contract), the certificates, endorsements, and other evidence of insurance required to be provided by Contractor in accordance with Article 6, except to the extent the Supplementary Conditions expressly establish other dates for delivery of specific insurance policies.~~
- C. ~~*Evidence of Owner’s Insurance*: After receipt of the signed counterparts of the Agreement and all required bonds and insurance documentation, Owner shall promptly deliver to Contractor, with copies to each additional insured (as identified in the Contract), the certificates and other evidence of insurance required to be provided by Owner under Article 6.~~

See SC-2.01

2.02 *Copies of Documents*

- A. ~~Owner shall furnish to Contractor four printed copies of the Contract (including one fully signed counterpart of the Agreement), and one copy in electronic portable document format (PDF). Additional printed copies will be furnished upon request at the cost of reproduction.~~

See SC-2.02

- B. Owner shall maintain and safeguard at least one original printed record version of the Contract, including Drawings and Specifications signed and sealed by Engineer and other design professionals. Owner shall make such original printed record version of the Contract available to Contractor for review. Owner may delegate the responsibilities under this provision to Engineer.

2.03 *Before Starting Construction*

- A. *Preliminary Schedules*: Within 10 days after the Effective Date of the Contract (or as otherwise required by the Contract Documents), Contractor shall submit to Engineer for timely review:
 1. a preliminary Progress Schedule indicating the times (numbers of days or dates) for starting and completing the various stages of the Work, including any Milestones specified in the Contract;
 2. a preliminary Schedule of Submittals; and

3. a preliminary Schedule of Values for all of the Work which includes quantities and prices of items which when added together equal the Contract Price and subdivides the Work into component parts in sufficient detail to serve as the basis for progress payments during performance of the Work. Such prices will include an appropriate amount of overhead and profit applicable to each item of Work.

2.04 *Preconstruction Conference; Designation of Authorized Representatives*

- A. Before any Work at the Site is started, a conference attended by Owner, Contractor, Engineer, and others as appropriate will be held to establish a working understanding among the parties as to the Work, and to discuss the schedules referred to in Paragraph 2.03.A, procedures for handling Shop Drawings, Samples, and other Submittals, processing Applications for Payment, electronic or digital transmittals, and maintaining required records.
- B. At this conference Owner and Contractor each shall designate, in writing, a specific individual to act as its authorized representative with respect to the services and responsibilities under the Contract. Such individuals shall have the authority to transmit and receive information, render decisions relative to the Contract, and otherwise act on behalf of each respective party.

2.05 *Acceptance of Schedules*

- A. At least 10 days before submission of the first Application for Payment a conference, attended by Contractor, Engineer, and others as appropriate, will be held to review the schedules submitted in accordance with Paragraph 2.03.A. No progress payment will be made to Contractor until acceptable schedules are submitted to Engineer.
 1. The Progress Schedule will be acceptable to Engineer if it provides an orderly progression of the Work to completion within the Contract Times. Such acceptance will not impose on Engineer responsibility for the Progress Schedule, for sequencing, scheduling, or progress of the Work, nor interfere with or relieve Contractor from Contractor's full responsibility therefor.
 2. Contractor's Schedule of Submittals will be acceptable to Engineer if it provides a workable arrangement for reviewing and processing the required submittals.
 3. Contractor's Schedule of Values will be acceptable to Engineer as to form and substance if it provides a reasonable allocation of the Contract Price to the component parts of the Work.
 4. If a schedule is not acceptable, Contractor will have an additional 10 days to revise and resubmit the schedule.

2.06 *Electronic Transmittals*

- A. Except as otherwise stated elsewhere in the Contract, the Owner, Engineer, and Contractor may send, and shall accept, Electronic Documents transmitted by Electronic Means.
- B. If the Contract does not establish protocols for Electronic Means, then Owner, Engineer, and Contractor shall jointly develop such protocols.
- C. Subject to any governing protocols for Electronic Means, when transmitting Electronic Documents by Electronic Means, the transmitting party makes no representations as to long-term compatibility, usability, or readability of the Electronic Documents resulting from the

recipient's use of software application packages, operating systems, or computer hardware differing from those used in the drafting or transmittal of the Electronic Documents.

ARTICLE 3—CONTRACT DOCUMENTS: INTENT, REQUIREMENTS, REUSE

3.01 *Intent*

- A. The Contract Documents are complementary; what is required by one Contract Document is as binding as if required by all.
- B. It is the intent of the Contract Documents to describe a functionally complete Project (or part thereof) to be constructed in accordance with the Contract Documents.
- C. ~~Unless otherwise stated in the Contract Documents, if there is a discrepancy between the electronic versions of the Contract Documents (including any printed copies derived from such electronic versions) and the printed record version, the printed record version will govern.~~

See SC-3.01

- D. The Contract supersedes prior negotiations, representations, and agreements, whether written or oral.
- E. Engineer will issue clarifications and interpretations of the Contract Documents as provided herein.
- F. Any provision or part of the Contract Documents held to be void or unenforceable under any Law or Regulation will be deemed stricken, and all remaining provisions will continue to be valid and binding upon Owner and Contractor, which agree that the Contract Documents will be reformed to replace such stricken provision or part thereof with a valid and enforceable provision that comes as close as possible to expressing the intention of the stricken provision.
- G. Nothing in the Contract Documents creates:
 - 1. any contractual relationship between Owner or Engineer and any Subcontractor, Supplier, or other individual or entity performing or furnishing any of the Work, for the benefit of such Subcontractor, Supplier, or other individual or entity; or
 - 2. any obligation on the part of Owner or Engineer to pay or to see to the payment of any money due any such Subcontractor, Supplier, or other individual or entity, except as may otherwise be required by Laws and Regulations.

3.02 *Reference Standards*

- A. *Standards Specifications, Codes, Laws and Regulations*
 - 1. Reference in the Contract Documents to standard specifications, manuals, reference standards, or codes of any technical society, organization, or association, or to Laws or Regulations, whether such reference be specific or by implication, means the standard specification, manual, reference standard, code, or Laws or Regulations in effect at the time of opening of Bids (or on the Effective Date of the Contract if there were no Bids), except as may be otherwise specifically stated in the Contract Documents.
 - 2. No provision of any such standard specification, manual, reference standard, or code, and no instruction of a Supplier, will be effective to change the duties or responsibilities of Owner, Contractor, or Engineer from those set forth in the part of the Contract

EJCDC® C-700, Standard General Conditions of the Construction Contract.

Copyright© 2018 National Society of Professional Engineers, American Council of Engineering Companies, and American Society of Civil Engineers. All rights reserved.

Documents prepared by or for Engineer. No such provision or instruction shall be effective to assign to Owner or Engineer any duty or authority to supervise or direct the performance of the Work, or any duty or authority to undertake responsibility inconsistent with the provisions of the part of the Contract Documents prepared by or for Engineer.

3.03 *Reporting and Resolving Discrepancies*

A. *Reporting Discrepancies*

1. *Contractor's Verification of Figures and Field Measurements:* Before undertaking each part of the Work, Contractor shall carefully study the Contract Documents, and check and verify pertinent figures and dimensions therein, particularly with respect to applicable field measurements. Contractor shall promptly report in writing to Engineer any conflict, error, ambiguity, or discrepancy that Contractor discovers, or has actual knowledge of, and shall not proceed with any Work affected thereby until the conflict, error, ambiguity, or discrepancy is resolved by a clarification or interpretation by Engineer, or by an amendment or supplement to the Contract issued pursuant to Paragraph 11.01.
2. *Contractor's Review of Contract Documents:* If, before or during the performance of the Work, Contractor discovers any conflict, error, ambiguity, or discrepancy within the Contract Documents, or between the Contract Documents and (a) any applicable Law or Regulation, (b) actual field conditions, (c) any standard specification, manual, reference standard, or code, or (d) any instruction of any Supplier, then Contractor shall promptly report it to Engineer in writing. Contractor shall not proceed with the Work affected thereby (except in an emergency as required by Paragraph 7.15) until the conflict, error, ambiguity, or discrepancy is resolved, by a clarification or interpretation by Engineer, or by an amendment or supplement to the Contract issued pursuant to Paragraph 11.01.
3. Contractor shall not be liable to Owner or Engineer for failure to report any conflict, error, ambiguity, or discrepancy in the Contract Documents unless Contractor had actual knowledge thereof.

B. *Resolving Discrepancies*

1. Except as may be otherwise specifically stated in the Contract Documents, the provisions of the part of the Contract Documents prepared by or for Engineer take precedence in resolving any conflict, error, ambiguity, or discrepancy between such provisions of the Contract Documents and:
 - a. the provisions of any standard specification, manual, reference standard, or code, or the instruction of any Supplier (whether or not specifically incorporated by reference as a Contract Document); or
 - b. the provisions of any Laws or Regulations applicable to the performance of the Work (unless such an interpretation of the provisions of the Contract Documents would result in violation of such Law or Regulation).

3.04 *Requirements of the Contract Documents*

- A. During the performance of the Work and until final payment, Contractor and Owner shall submit to the Engineer in writing all matters in question concerning the requirements of the Contract Documents (sometimes referred to as requests for information or interpretation—RFIs), or relating to the acceptability of the Work under the Contract Documents, as soon as

possible after such matters arise. Engineer will be the initial interpreter of the requirements of the Contract Documents, and judge of the acceptability of the Work.

- B. Engineer will, with reasonable promptness, render a written clarification, interpretation, or decision on the issue submitted, or initiate an amendment or supplement to the Contract Documents. Engineer's written clarification, interpretation, or decision will be final and binding on Contractor, unless it appeals by submitting a Change Proposal, and on Owner, unless it appeals by filing a Claim.
- C. If a submitted matter in question concerns terms and conditions of the Contract Documents that do not involve (1) the performance or acceptability of the Work under the Contract Documents, (2) the design (as set forth in the Drawings, Specifications, or otherwise), or (3) other engineering or technical matters, then Engineer will promptly notify Owner and Contractor in writing that Engineer is unable to provide a decision or interpretation. If Owner and Contractor are unable to agree on resolution of such a matter in question, either party may pursue resolution as provided in Article 12.

3.05 *Reuse of Documents*

- A. Contractor and its Subcontractors and Suppliers shall not:
 - 1. have or acquire any title to or ownership rights in any of the Drawings, Specifications, or other documents (or copies of any thereof) prepared by or bearing the seal of Engineer or its consultants, including electronic media versions, or reuse any such Drawings, Specifications, other documents, or copies thereof on extensions of the Project or any other project without written consent of Owner and Engineer and specific written verification or adaptation by Engineer; or
 - 2. have or acquire any title or ownership rights in any other Contract Documents, reuse any such Contract Documents for any purpose without Owner's express written consent, or violate any copyrights pertaining to such Contract Documents.
- B. The prohibitions of this Paragraph 3.05 will survive final payment, or termination of the Contract. Nothing herein precludes Contractor from retaining copies of the Contract Documents for record purposes.

ARTICLE 4—COMMENCEMENT AND PROGRESS OF THE WORK

4.01 *Commencement of Contract Times; Notice to Proceed*

- A. The Contract Times will commence to run on the 30th day after the Effective Date of the Contract or, if a Notice to Proceed is given, on the day indicated in the Notice to Proceed. A Notice to Proceed may be given at any time within 30 days after the Effective Date of the Contract. ~~In no event will the Contract Times commence to run later than the 60th day after the day of Bid opening or the 30th day after the Effective Date of the Contract, whichever date is earlier.~~

See SC-4.01

4.02 *Starting the Work*

- A. Contractor shall start to perform the Work on the date when the Contract Times commence to run. No Work may be done at the Site prior to such date.

4.03 *Reference Points*

- A. ~~Owner shall provide engineering surveys to establish reference points for construction which in Engineer's judgment are necessary to enable Contractor to proceed with the Work.~~ Contractor shall be responsible for laying out the Work, shall protect and preserve the established reference points and property monuments, and shall make no changes or relocations without the prior written approval of Owner. Contractor shall report to Engineer whenever any reference point or property monument is lost or destroyed or requires relocation because of necessary changes in grades or locations, and shall be responsible for the accurate replacement or relocation of such reference points or property monuments by professionally qualified personnel.

See SC-4.03

4.04 *Progress Schedule*

- A. Contractor shall adhere to the Progress Schedule established in accordance with Paragraph 2.05 as it may be adjusted from time to time as provided below.
1. Contractor shall submit to Engineer for acceptance (to the extent indicated in Paragraph 2.05) proposed adjustments in the Progress Schedule that will not result in changing the Contract Times.
 2. Proposed adjustments in the Progress Schedule that will change the Contract Times must be submitted in accordance with the requirements of Article 11.
- B. Contractor shall carry on the Work and adhere to the Progress Schedule during all disputes or disagreements with Owner. No Work will be delayed or postponed pending resolution of any disputes or disagreements, or during any appeal process, except as permitted by Paragraph 16.04, or as Owner and Contractor may otherwise agree in writing.

See SC-4.04

4.05 *Delays in Contractor's Progress*

- A. If Owner, Engineer, or anyone for whom Owner is responsible, delays, disrupts, or interferes with the performance or progress of the Work, then Contractor shall be entitled to an equitable adjustment in Contract Price or Contract Times.
- B. Contractor shall not be entitled to an adjustment in Contract Price or Contract Times for delay, disruption, or interference caused by or within the control of Contractor. Delay, disruption, and interference attributable to and within the control of a Subcontractor or Supplier shall be deemed to be within the control of Contractor.
- C. If Contractor's performance or progress is delayed, disrupted, or interfered with by unanticipated causes not the fault of and beyond the control of Owner, Contractor, and those for which they are responsible, then Contractor shall be entitled to an equitable adjustment in Contract Times. Such an adjustment will be Contractor's sole and exclusive remedy for the delays, disruption, and interference described in this paragraph. Causes of delay, disruption, or interference that may give rise to an adjustment in Contract Times under this paragraph include but are not limited to the following:
1. Severe and unavoidable natural catastrophes such as fires, floods, epidemics, and earthquakes;

2. Abnormal weather conditions;
 3. Acts or failures to act of third-party utility owners or other third-party entities (other than those third-party utility owners or other third-party entities performing other work at or adjacent to the Site as arranged by or under contract with Owner, as contemplated in Article 8); and
 4. Acts of war or terrorism.
- D. Contractor's entitlement to an adjustment of Contract Times or Contract Price is limited as follows:
1. Contractor's entitlement to an adjustment of the Contract Times is conditioned on the delay, disruption, or interference adversely affecting an activity on the critical path to completion of the Work, as of the time of the delay, disruption, or interference.
 2. Contractor shall not be entitled to an adjustment in Contract Price for any delay, disruption, or interference if such delay is concurrent with a delay, disruption, or interference caused by or within the control of Contractor. Such a concurrent delay by Contractor shall not preclude an adjustment of Contract Times to which Contractor is otherwise entitled.
 3. Adjustments of Contract Times or Contract Price are subject to the provisions of Article 11.
- E. Each Contractor request or Change Proposal seeking an increase in Contract Times or Contract Price must be supplemented by supporting data that sets forth in detail the following:
1. The circumstances that form the basis for the requested adjustment;
 2. The date upon which each cause of delay, disruption, or interference began to affect the progress of the Work;
 3. The date upon which each cause of delay, disruption, or interference ceased to affect the progress of the Work;
 4. The number of days' increase in Contract Times claimed as a consequence of each such cause of delay, disruption, or interference; and
 5. The impact on Contract Price, in accordance with the provisions of Paragraph 11.07.
- Contractor shall also furnish such additional supporting documentation as Owner or Engineer may require including, where appropriate, a revised progress schedule indicating all the activities affected by the delay, disruption, or interference, and an explanation of the effect of the delay, disruption, or interference on the critical path to completion of the Work.
- F. Delays, disruption, and interference to the performance or progress of the Work resulting from the existence of a differing subsurface or physical condition, an Underground Facility that was not shown or indicated by the Contract Documents, or not shown or indicated with reasonable accuracy, and those resulting from Hazardous Environmental Conditions, are governed by Article 5, together with the provisions of Paragraphs 4.05.D and 4.05.E.
- G. Paragraph 8.03 addresses delays, disruption, and interference to the performance or progress of the Work resulting from the performance of certain other work at or adjacent to the Site.

ARTICLE 5—SITE; SUBSURFACE AND PHYSICAL CONDITIONS; HAZARDOUS ENVIRONMENTAL CONDITIONS

5.01 *Availability of Lands*

- A. Owner shall furnish the Site. Owner shall notify Contractor in writing of any encumbrances or restrictions not of general application but specifically related to use of the Site with which Contractor must comply in performing the Work.
- B. Upon reasonable written request, Owner shall furnish Contractor with a current statement of record legal title and legal description of the lands upon which permanent improvements are to be made and Owner's interest therein as necessary for giving notice of or filing a mechanic's or construction lien against such lands in accordance with applicable Laws and Regulations.
- C. Contractor shall provide for all additional lands and access thereto that may be required for temporary construction facilities or storage of materials and equipment.

5.02 *Use of Site and Other Areas*

A. *Limitation on Use of Site and Other Areas*

- 1. Contractor shall confine construction equipment, temporary construction facilities, the storage of materials and equipment, and the operations of workers to the Site, adjacent areas that Contractor has arranged to use through construction easements or otherwise, and other adjacent areas permitted by Laws and Regulations, and shall not unreasonably encumber the Site and such other adjacent areas with construction equipment or other materials or equipment. Contractor shall assume full responsibility for (a) damage to the Site; (b) damage to any such other adjacent areas used for Contractor's operations; (c) damage to any other adjacent land or areas, or to improvements, structures, utilities, or similar facilities located at such adjacent lands or areas; and (d) for injuries and losses sustained by the owners or occupants of any such land or areas; provided that such damage or injuries result from the performance of the Work or from other actions or conduct of the Contractor or those for which Contractor is responsible.

See SC -5.02

- 2. If a damage or injury claim is made by the owner or occupant of any such land or area because of the performance of the Work, or because of other actions or conduct of the Contractor or those for which Contractor is responsible, Contractor shall (a) take immediate corrective or remedial action as required by Paragraph 7.13, or otherwise; (b) promptly attempt to settle the claim as to all parties through negotiations with such owner or occupant, or otherwise resolve the claim by arbitration or other dispute resolution proceeding, or in a court of competent jurisdiction; and (c) to the fullest extent permitted by Laws and Regulations, indemnify and hold harmless Owner and Engineer, and the officers, directors, members, partners, employees, agents, consultants and subcontractors of each and any of them, from and against any such claim, and against all costs, losses, and damages (including but not limited to all fees and charges of engineers, architects, attorneys, and other professionals and all court or arbitration or other dispute resolution costs) arising out of or relating to any claim or action, legal or equitable, brought by any such owner or occupant against Owner, Engineer, or any other party indemnified hereunder to the extent caused directly or indirectly, in whole or in part by,

or based upon, Contractor's performance of the Work, or because of other actions or conduct of the Contractor or those for which Contractor is responsible.

- B. *Removal of Debris During Performance of the Work:* During the progress of the Work the Contractor shall keep the Site and other adjacent areas free from accumulations of waste materials, rubbish, and other debris. Removal and disposal of such waste materials, rubbish, and other debris will conform to applicable Laws and Regulations.
- C. *Cleaning:* Prior to Substantial Completion of the Work Contractor shall clean the Site and the Work and make it ready for utilization by Owner. At the completion of the Work Contractor shall remove from the Site and adjacent areas all tools, appliances, construction equipment and machinery, and surplus materials and shall restore to original condition all property not designated for alteration by the Contract Documents.
- D. *Loading of Structures:* Contractor shall not load nor permit any part of any structure to be loaded in any manner that will endanger the structure, nor shall Contractor subject any part of the Work or adjacent structures or land to stresses or pressures that will endanger them.

5.03 *Subsurface and Physical Conditions*

- A. *Reports and Drawings:* The Supplementary Conditions identify:
 - 1. Those reports of explorations and tests of subsurface conditions at or adjacent to the Site that contain Technical Data;
 - 2. Those drawings of existing physical conditions at or adjacent to the Site, including those drawings depicting existing surface or subsurface structures at or adjacent to the Site (except Underground Facilities), that contain Technical Data; and
 - 3. Technical Data contained in such reports and drawings.
- B. *Underground Facilities:* Underground Facilities are shown or indicated on the Drawings, pursuant to Paragraph 5.05, and not in the drawings referred to in Paragraph 5.03.A. Information and data regarding the presence or location of Underground Facilities are not intended to be categorized, identified, or defined as Technical Data.
- C. ~~*Reliance by Contractor on Technical Data:* Contractor may rely upon the accuracy of the Technical Data expressly identified in the Supplementary Conditions with respect to such reports and drawings, but such reports and drawings are not Contract Documents. If no such express identification has been made, then Contractor may rely upon the accuracy of the Technical Data as defined in Paragraph 1.01.A.46.b.~~

See SC-5.03

- D. *Limitations of Other Data and Documents:* Except for such reliance on Technical Data, Contractor may not rely upon or make any claim against Owner or Engineer, or any of their officers, directors, members, partners, employees, agents, consultants, or subcontractors, with respect to:
 - 1. The completeness of such reports and drawings for Contractor's purposes, including, but not limited to, any aspects of the means, methods, techniques, sequences, and procedures of construction to be employed by Contractor, and safety precautions and programs incident thereto;

2. Other data, interpretations, opinions, and information contained in such reports or shown or indicated in such drawings;
3. The contents of other Site-related documents made available to Contractor, such as record drawings from other projects at or adjacent to the Site, or Owner's archival documents concerning the Site; or
4. Any Contractor interpretation of or conclusion drawn from any Technical Data or any such other data, interpretations, opinions, or information.

See SC-5.03

5.04 *Differing Subsurface or Physical Conditions*

- A. ~~*Notice by Contractor:* If Contractor believes that any subsurface or physical condition that is uncovered or revealed at the Site:~~
- ~~1. is of such a nature as to establish that any Technical Data on which Contractor is entitled to rely as provided in Paragraph 5.03 is materially inaccurate;~~
 - ~~2. is of such a nature as to require a change in the Drawings or Specifications;~~
 - ~~3. Differs materially from that shown or indicated in the Contract Documents; or~~
 - ~~4. Is of an unusual nature, and differs materially from conditions ordinarily encountered and generally recognized as inherent in work of the character provided for in the Contract Documents;~~

~~then Contractor shall, promptly after becoming aware thereof and before further disturbing the subsurface or physical conditions or performing any Work in connection therewith (except in an emergency as required by Paragraph 7.15), notify Owner and Engineer in writing about such condition. Contractor shall not further disturb such condition or perform any Work in connection therewith (except with respect to an emergency) until receipt of a written statement permitting Contractor to do so.~~

See SC-5.04

- B. *Engineer's Review:* After receipt of written notice as required by the preceding paragraph, Engineer will promptly review the subsurface or physical condition in question; determine whether it is necessary for Owner to obtain additional exploration or tests with respect to the condition; conclude whether the condition falls within any one or more of the differing site condition categories in Paragraph 5.04.A; obtain any pertinent cost or schedule information from Contractor; prepare recommendations to Owner regarding the Contractor's resumption of Work in connection with the subsurface or physical condition in question and the need for any change in the Drawings or Specifications; and advise Owner in writing of Engineer's findings, conclusions, and recommendations.
- C. *Owner's Statement to Contractor Regarding Site Condition:* After receipt of Engineer's written findings, conclusions, and recommendations, Owner shall issue a written statement to Contractor (with a copy to Engineer) regarding the subsurface or physical condition in question, addressing the resumption of Work in connection with such condition, indicating whether any change in the Drawings or Specifications will be made, and adopting or rejecting Engineer's written findings, conclusions, and recommendations, in whole or in part.

- D. *Early Resumption of Work*: If at any time Engineer determines that Work in connection with the subsurface or physical condition in question may resume prior to completion of Engineer's review or Owner's issuance of its statement to Contractor, because the condition in question has been adequately documented, and analyzed on a preliminary basis, then the Engineer may at its discretion instruct Contractor to resume such Work.
- E. *Possible Price and Times Adjustments*
1. Contractor shall be entitled to an equitable adjustment in Contract Price or Contract Times, to the extent that the existence of a differing subsurface or physical condition, or any related delay, disruption, or interference, causes an increase or decrease in Contractor's cost of, or time required for, performance of the Work; subject, however, to the following:
 - a. Such condition must fall within any one or more of the categories described in Paragraph 5.04.A;
 - b. With respect to Work that is paid for on a unit price basis, any adjustment in Contract Price will be subject to the provisions of Paragraph 13.03; and,
 - c. Contractor's entitlement to an adjustment of the Contract Times is subject to the provisions of Paragraphs 4.05.D and 4.05.E.
 2. Contractor shall not be entitled to any adjustment in the Contract Price or Contract Times with respect to a subsurface or physical condition if:
 - a. Contractor knew of the existence of such condition at the time Contractor made a commitment to Owner with respect to Contract Price and Contract Times by the submission of a Bid or becoming bound under a negotiated contract, or otherwise;
 - b. The existence of such condition reasonably could have been discovered or revealed as a result of any examination, investigation, exploration, test, or study of the Site and contiguous areas expressly required by the Bidding Requirements or Contract Documents to be conducted by or for Contractor prior to Contractor's making such commitment; or
 - c. Contractor failed to give the written notice required by Paragraph 5.04.A.
 3. If Owner and Contractor agree regarding Contractor's entitlement to and the amount or extent of any adjustment in the Contract Price or Contract Times, then any such adjustment will be set forth in a Change Order.

See SC-5.04.E.4

- ~~4. Contractor may submit a Change Proposal regarding its entitlement to or the amount or extent of any adjustment in the Contract Price or Contract Times, no later than 30 days after Owner's issuance of the Owner's written statement to Contractor regarding the subsurface or physical condition in question.~~
- F. *Underground Facilities; Hazardous Environmental Conditions*: Paragraph 5.05 governs rights and responsibilities regarding the presence or location of Underground Facilities. Paragraph 5.06 governs rights and responsibilities regarding Hazardous Environmental Conditions. The provisions of Paragraphs 5.03 and 5.04 are not applicable to the presence or location of Underground Facilities, or to Hazardous Environmental Conditions.

5.05 *Underground Facilities*

- A. *Contractor's Responsibilities:* Unless it is otherwise expressly provided in the Supplementary Conditions, the cost of all of the following are included in the Contract Price, and Contractor shall have full responsibility for:
1. reviewing and checking all information and data regarding existing Underground Facilities at the Site;
 2. complying with applicable state and local utility damage prevention Laws and Regulations;
 3. Verifying the actual location of those Underground Facilities shown or indicated in the Contract Documents as being within the area affected by the Work, by exposing such Underground Facilities during the course of construction;
 4. coordination of the Work with the owners (including Owner) of such Underground Facilities, during construction; and
 5. the safety and protection of all existing Underground Facilities at the Site, and repairing any damage thereto resulting from the Work.
- B. *Notice by Contractor:* If Contractor believes that an Underground Facility that is uncovered or revealed at the Site was not shown or indicated on the Drawings, or was not shown or indicated on the Drawings with reasonable accuracy, then Contractor shall, promptly after becoming aware thereof and before further disturbing conditions affected thereby or performing any Work in connection therewith (except in an emergency as required by Paragraph 7.15), notify Owner and Engineer in writing regarding such Underground Facility.
- C. *Engineer's Review:* Engineer will:
1. promptly review the Underground Facility and conclude whether such Underground Facility was not shown or indicated on the Drawings, or was not shown or indicated with reasonable accuracy;
 2. identify and communicate with the owner of the Underground Facility; prepare recommendations to Owner (and if necessary issue any preliminary instructions to Contractor) regarding the Contractor's resumption of Work in connection with the Underground Facility in question;
 3. obtain any pertinent cost or schedule information from Contractor; determine the extent, if any, to which a change is required in the Drawings or Specifications to reflect and document the consequences of the existence or location of the Underground Facility; and
 4. advise Owner in writing of Engineer's findings, conclusions, and recommendations.
- During such time, Contractor shall be responsible for the safety and protection of such Underground Facility.
- D. *Owner's Statement to Contractor Regarding Underground Facility:* After receipt of Engineer's written findings, conclusions, and recommendations, Owner shall issue a written statement to Contractor (with a copy to Engineer) regarding the Underground Facility in question addressing the resumption of Work in connection with such Underground Facility, indicating whether any change in the Drawings or Specifications will be made, and adopting or rejecting Engineer's written findings, conclusions, and recommendations in whole or in part.

- E. *Early Resumption of Work*: If at any time Engineer determines that Work in connection with the Underground Facility may resume prior to completion of Engineer's review or Owner's issuance of its statement to Contractor, because the Underground Facility in question and conditions affected by its presence have been adequately documented, and analyzed on a preliminary basis, then the Engineer may at its discretion instruct Contractor to resume such Work.
- F. *Possible Price and Times Adjustments*
1. Contractor shall be entitled to an equitable adjustment in the Contract Price or Contract Times, to the extent that any existing Underground Facility at the Site that was not shown or indicated on the Drawings, or was not shown or indicated with reasonable accuracy, or any related delay, disruption, or interference, causes an increase or decrease in Contractor's cost of, or time required for, performance of the Work; subject, however, to the following:
 - a. With respect to Work that is paid for on a unit price basis, any adjustment in Contract Price will be subject to the provisions of Paragraph 13.03;
 - b. Contractor's entitlement to an adjustment of the Contract Times is subject to the provisions of Paragraphs 4.05.D and 4.05.E; and
 - c. Contractor gave the notice required in Paragraph 5.05.B.
 2. If Owner and Contractor agree regarding Contractor's entitlement to and the amount or extent of any adjustment in the Contract Price or Contract Times, then any such adjustment will be set forth in a Change Order.
 3. Contractor may submit a Change Proposal regarding its entitlement to or the amount or extent of any adjustment in the Contract Price or Contract Times, no later than 30 days after Owner's issuance of the Owner's written statement to Contractor regarding the Underground Facility in question.
 4. The information and data shown or indicated on the Drawings with respect to existing Underground Facilities at the Site is based on information and data (a) furnished by the owners of such Underground Facilities, or by others, (b) obtained from available records, or (c) gathered in an investigation conducted in accordance with the current edition of ASCE 38, Standard Guideline for the Collection and Depiction of Existing Subsurface Utility Data, by the American Society of Civil Engineers. If such information or data is incorrect or incomplete, Contractor's remedies are limited to those set forth in this Paragraph 5.05.F.

5.06 *Hazardous Environmental Conditions at Site*

- A. ~~*Reports and Drawings*: The Supplementary Conditions identify:~~
- ~~1. Those reports known to Owner relating to Hazardous Environmental Conditions that have been identified at or adjacent to the Site;~~
 - ~~2. Drawings known to Owner relating to Hazardous Environmental Conditions that have been identified at or adjacent to the Site; and~~
 - ~~3. Technical Data contained in such reports and drawings.~~

- ~~B. *Reliance by Contractor on Technical Data Authorized:* Contractor may rely upon the accuracy of the Technical Data expressly identified in the Supplementary Conditions with respect to such reports and drawings, but such reports and drawings are not Contract Documents. If no such express identification has been made, then Contractor may rely on the accuracy of the Technical Data as defined in Paragraph 1.01.A.46.b. Except for such reliance on Technical Data, Contractor may not rely upon or make any claim against Owner or Engineer, or any of their officers, directors, members, partners, employees, agents, consultants, or subcontractors, with respect to:~~
- ~~1. the completeness of such reports and drawings for Contractor's purposes, including, but not limited to, any aspects of the means, methods, techniques, sequences and procedures of construction to be employed by Contractor, and safety precautions and programs incident thereto;~~
 - ~~2. Other data, interpretations, opinions, and information contained in such reports or shown or indicated in such drawings; or~~
 - ~~3. Any Contractor interpretation of or conclusion drawn from any Technical Data or any such other data, interpretations, opinions or information.~~

See SC-5.06

- C. Contractor shall not be responsible for removing or remediating any Hazardous Environmental Condition encountered, uncovered, or revealed at the Site unless such removal or remediation is expressly identified in the Contract Documents to be within the scope of the Work.
- D. Contractor shall be responsible for controlling, containing, and duly removing all Constituents of Concern brought to the Site by Contractor, Subcontractors, Suppliers, or anyone else for whom Contractor is responsible, and for any associated costs; and for the costs of removing and remediating any Hazardous Environmental Condition created by the presence of any such Constituents of Concern.
- E. If Contractor encounters, uncovers, or reveals a Hazardous Environmental Condition whose removal or remediation is not expressly identified in the Contract Documents as being within the scope of the Work, or if Contractor or anyone for whom Contractor is responsible creates a Hazardous Environmental Condition, then Contractor shall immediately: (1) secure or otherwise isolate such condition; (2) stop all Work in connection with such condition and in any area affected thereby (except in an emergency as required by Paragraph 7.15); and (3) notify Owner and Engineer (and promptly thereafter confirm such notice in writing). Owner shall promptly consult with Engineer concerning the necessity for Owner to retain a qualified expert to evaluate such condition or take corrective action, if any. Promptly after consulting with Engineer, Owner shall take such actions as are necessary to permit Owner to timely obtain required permits and provide Contractor the written notice required by Paragraph 5.06.F. If Contractor or anyone for whom Contractor is responsible created the Hazardous Environmental Condition in question, then Owner may remove and remediate the Hazardous Environmental Condition, and impose a set-off against payments to account for the associated costs.
- F. Contractor shall not resume Work in connection with such Hazardous Environmental Condition or in any affected area until after Owner has obtained any required permits related thereto, and delivered written notice to Contractor either (1) specifying that such condition

- and any affected area is or has been rendered safe for the resumption of Work, or (2) specifying any special conditions under which such Work may be resumed safely.
- G. If Owner and Contractor cannot agree as to entitlement to or on the amount or extent, if any, of any adjustment in Contract Price or Contract Times, as a result of such Work stoppage, such special conditions under which Work is agreed to be resumed by Contractor, or any costs or expenses incurred in response to the Hazardous Environmental Condition, then within 30 days of Owner's written notice regarding the resumption of Work, Contractor may submit a Change Proposal, or Owner may impose a set-off. Entitlement to any such adjustment is subject to the provisions of Paragraphs 4.05.D, 4.05.E, 11.07, and 11.08.
 - H. If, after receipt of such written notice, Contractor does not agree to resume such Work based on a reasonable belief it is unsafe, or does not agree to resume such Work under such special conditions, then Owner may order the portion of the Work that is in the area affected by such condition to be deleted from the Work, following the contractual change procedures in Article 11. Owner may have such deleted portion of the Work performed by Owner's own forces or others in accordance with Article 8.
 - I. To the fullest extent permitted by Laws and Regulations, Owner shall indemnify and hold harmless Contractor, Subcontractors, and Engineer, and the officers, directors, members, partners, employees, agents, consultants, and subcontractors of each and any of them, from and against all claims, costs, losses, and damages (including but not limited to all fees and charges of engineers, architects, attorneys, and other professionals, and all court, arbitration, or other dispute resolution costs) arising out of or relating to a Hazardous Environmental Condition, provided that such Hazardous Environmental Condition (1) was not shown or indicated in the Drawings, Specifications, or other Contract Documents, identified as Technical Data entitled to limited reliance pursuant to Paragraph 5.06.B, or identified in the Contract Documents to be included within the scope of the Work, and (2) was not created by Contractor or by anyone for whom Contractor is responsible. Nothing in this Paragraph 5.06.I obligates Owner to indemnify any individual or entity from and against the consequences of that individual's or entity's own negligence.
 - J. To the fullest extent permitted by Laws and Regulations, Contractor shall indemnify and hold harmless Owner and Engineer, and the officers, directors, members, partners, employees, agents, consultants, and subcontractors of each and any of them, from and against all claims, costs, losses, and damages (including but not limited to all fees and charges of engineers, architects, attorneys, and other professionals and all court or arbitration or other dispute resolution costs) arising out of or relating to the failure to control, contain, or remove a Constituent of Concern brought to the Site by Contractor or by anyone for whom Contractor is responsible, or to a Hazardous Environmental Condition created by Contractor or by anyone for whom Contractor is responsible. Nothing in this Paragraph 5.06.J obligates Contractor to indemnify any individual or entity from and against the consequences of that individual's or entity's own negligence.
 - K. The provisions of Paragraphs 5.03, 5.04, and 5.05 do not apply to the presence of Constituents of Concern or to a Hazardous Environmental Condition uncovered or revealed at the Site.

ARTICLE 6—BONDS AND INSURANCE

6.01 *Performance, Payment, and Other Bonds*

- A. Contractor shall furnish a performance bond and a payment bond, each in an amount at least equal to the Contract Price, as security for the faithful performance and payment of Contractor's obligations under the Contract. These bonds must remain in effect until one year after the date when final payment becomes due or until completion of the correction period specified in Paragraph 15.08, whichever is later, except as provided otherwise by Laws or Regulations, the terms of a prescribed bond form, the Supplementary Conditions, or other provisions of the Contract.
- B. Contractor shall also furnish such other bonds (if any) as are required by the Supplementary Conditions or other provisions of the Contract.
- C. All bonds must be in the form included in the Bidding Documents or otherwise specified by Owner prior to execution of the Contract, except as provided otherwise by Laws or Regulations, and must be issued and signed by a surety named in "Companies Holding Certificates of Authority as Acceptable Sureties on Federal Bonds and as Acceptable Reinsuring Companies" as published in Department Circular 570 (as amended and supplemented) by the Bureau of the Fiscal Service, U.S. Department of the Treasury. A bond signed by an agent or attorney-in-fact must be accompanied by a certified copy of that individual's authority to bind the surety. The evidence of authority must show that it is effective on the date the agent or attorney-in-fact signed the accompanying bond.
- D. Contractor shall obtain the required bonds from surety companies that are duly licensed or authorized, in the state or jurisdiction in which the Project is located, to issue bonds in the required amounts.
- E. If the surety on a bond furnished by Contractor is declared bankrupt or becomes insolvent, or the surety ceases to meet the requirements above, then Contractor shall promptly notify Owner and Engineer in writing and shall, within 20 days after the event giving rise to such notification, provide another bond and surety, both of which must comply with the bond and surety requirements above.
- F. If Contractor has failed to obtain a required bond, Owner may exclude the Contractor from the Site and exercise Owner's termination rights under Article 16.
- G. Upon request to Owner from any Subcontractor, Supplier, or other person or entity claiming to have furnished labor, services, materials, or equipment used in the performance of the Work, Owner shall provide a copy of the payment bond to such person or entity.
- H. Upon request to Contractor from any Subcontractor, Supplier, or other person or entity claiming to have furnished labor, services, materials, or equipment used in the performance of the Work, Contractor shall provide a copy of the payment bond to such person or entity.

6.02 *Insurance—General Provisions*

- A. Owner and Contractor shall obtain and maintain insurance as required in this article and in the Supplementary Conditions.

See SC-6.02

- B. All insurance required by the Contract to be purchased and maintained by Owner or Contractor shall be obtained from insurance companies that are duly licensed or authorized in the state or jurisdiction in which the Project is located to issue insurance policies for the required limits and coverages. Unless a different standard is indicated in the Supplementary Conditions, all companies that provide insurance policies required under this Contract shall have an A.M. Best rating of A-VII or better.
- C. Alternative forms of insurance coverage, including but not limited to self-insurance and "Occupational Accident and Excess Employer's Indemnity Policies," are not sufficient to meet the insurance requirements of this Contract, unless expressly allowed in the Supplementary Conditions.
- D. Contractor shall deliver to Owner, with copies to each additional insured identified in the Contract, certificates of insurance and endorsements establishing that Contractor has obtained and is maintaining the policies and coverages required by the Contract. Upon request by Owner or any other insured, Contractor shall also furnish other evidence of such required insurance, including but not limited to copies of policies, documentation of applicable self-insured retentions (if allowed) and deductibles, full disclosure of all relevant exclusions, and evidence of insurance required to be purchased and maintained by Subcontractors or Suppliers. In any documentation furnished under this provision, Contractor, Subcontractors, and Suppliers may block out (redact) (1) any confidential premium or pricing information and (2) any wording specific to a project or jurisdiction other than those applicable to this Contract.
- E. Owner shall deliver to Contractor, with copies to each additional insured identified in the Contract, certificates of insurance and endorsements establishing that Owner has obtained and is maintaining the policies and coverages required of Owner by the Contract (if any). Upon request by Contractor or any other insured, Owner shall also provide other evidence of such required insurance (if any), including but not limited to copies of policies, documentation of applicable self-insured retentions (if allowed) and deductibles, and full disclosure of all relevant exclusions. In any documentation furnished under this provision, Owner may block out (redact) (1) any confidential premium or pricing information and (2) any wording specific to a project or jurisdiction other than those relevant to this Contract.
- F. Failure of Owner or Contractor to demand such certificates or other evidence of the other party's full compliance with these insurance requirements, or failure of Owner or Contractor to identify a deficiency in compliance from the evidence provided, will not be construed as a waiver of the other party's obligation to obtain and maintain such insurance.
- G. In addition to the liability insurance required to be provided by Contractor, the Owner, at Owner's option, may purchase and maintain Owner's own liability insurance. Owner's liability policies, if any, operate separately and independently from policies required to be provided by Contractor, and Contractor cannot rely upon Owner's liability policies for any of Contractor's obligations to the Owner, Engineer, or third parties.
- H. Contractor shall require:
 - 1. Subcontractors to purchase and maintain worker's compensation, commercial general liability, and other insurance that is appropriate for their participation in the Project, and to name as additional insureds Owner and Engineer (and any other individuals or entities

identified in the Supplementary Conditions as additional insureds on Contractor's liability policies) on each Subcontractor's commercial general liability insurance policy; and

2. Suppliers to purchase and maintain insurance that is appropriate for their participation in the Project.
- I. If either party does not purchase or maintain the insurance required of such party by the Contract, such party shall notify the other party in writing of such failure to purchase prior to the start of the Work, or of such failure to maintain prior to any change in the required coverage.
- J. If Contractor has failed to obtain and maintain required insurance, Contractor's entitlement to enter or remain at the Site will end immediately, and Owner may impose an appropriate set-off against payment for any associated costs (including but not limited to the cost of purchasing necessary insurance coverage), and exercise Owner's termination rights under Article 16.

See SC-6.02

- L. Without prejudice to any other right or remedy, if a party has failed to obtain required insurance, the other party may elect (but is in no way obligated) to obtain equivalent insurance to protect such other party's interests at the expense of the party who was required to provide such coverage, and the Contract Price will be adjusted accordingly.
- M. Owner does not represent that insurance coverage and limits established in this Contract necessarily will be adequate to protect Contractor or Contractor's interests. Contractor is responsible for determining whether such coverage and limits are adequate to protect its interests, and for obtaining and maintaining any additional insurance that Contractor deems necessary.
- N. The insurance and insurance limits required herein will not be deemed as a limitation on Contractor's liability, or that of its Subcontractors or Suppliers, under the indemnities granted to Owner and other individuals and entities in the Contract or otherwise.
- O. All the policies of insurance required to be purchased and maintained under this Contract will contain a provision or endorsement that the coverage afforded will not be canceled, or renewal refused, until at least 10 days prior written notice has been given to the purchasing policyholder. Within three days of receipt of any such written notice, the purchasing policyholder shall provide a copy of the notice to each other insured and Engineer.

6.03 *Contractor's Insurance*

- A. *Required Insurance:* Contractor shall purchase and maintain Worker's Compensation, Commercial General Liability, and other insurance pursuant to the specific requirements of the Supplementary Conditions.

See SC-6.03

- B. *General Provisions:* The policies of insurance required by this Paragraph 6.03 as supplemented must:
 1. include at least the specific coverages required;
 2. be written for not less than the limits provided, or those required by Laws or Regulations, whichever is greater;

3. remain in effect at least until the Work is complete (as set forth in Paragraph 15.06.D), and longer if expressly required elsewhere in this Contract, and at all times thereafter when Contractor may be correcting, removing, or replacing defective Work as a warranty or correction obligation, or otherwise, or returning to the Site to conduct other tasks arising from the Contract;
 4. apply with respect to the performance of the Work, whether such performance is by Contractor, any Subcontractor or Supplier, or by anyone directly or indirectly employed by any of them to perform any of the Work, or by anyone for whose acts any of them may be liable; and
 5. include all necessary endorsements to support the stated requirements.
- C. *Additional Insureds*: The Contractor's commercial general liability, automobile liability, employer's liability, umbrella or excess, pollution liability, and unmanned aerial vehicle liability policies, if required by this Contract, must:
1. include and list as additional insureds Owner and Engineer, and any individuals or entities identified as additional insureds in the Supplementary Conditions;
 2. include coverage for the respective officers, directors, members, partners, employees, and consultants of all such additional insureds;
 3. afford primary coverage to these additional insureds for all claims covered thereby (including as applicable those arising from both ongoing and completed operations);
 4. not seek contribution from insurance maintained by the additional insured; and
 5. As to commercial general liability insurance, apply to additional insureds with respect to liability caused in whole or in part by Contractor's acts or omissions, or the acts and omissions of those working on Contractor's behalf, in the performance of Contractor's operations.

See SC-6.03

6.04 *Builder's Risk and Other Property Insurance*

- A. ~~*Builder's Risk*: Unless otherwise provided in the Supplementary Conditions, Contractor shall purchase and maintain builder's risk insurance upon the Work on a completed value basis, in the amount of the Work's full insurable replacement cost (subject to such deductible amounts as may be provided in the Supplementary Conditions or required by Laws and Regulations). The specific requirements applicable to the builder's risk insurance are set forth in the Supplementary Conditions.~~

See SC-6.04

- B. *Property Insurance for Facilities of Owner Where Work Will Occur*: Owner is responsible for obtaining and maintaining property insurance covering each existing structure, building, or facility in which any part of the Work will occur, or to which any part of the Work will attach or be adjoined. Such property insurance will be written on a special perils (all-risk) form, on a replacement cost basis, providing coverage consistent with that required for the builder's risk insurance, and will be maintained until the Work is complete, as set forth in Paragraph 15.06.D.

- C. *Property Insurance for Substantially Complete Facilities:* Promptly after Substantial Completion, and before actual occupancy or use of the substantially completed Work, Owner will obtain property insurance for such substantially completed Work, and maintain such property insurance at least until the Work is complete, as set forth in Paragraph 15.06.D. Such property insurance will be written on a special perils (all-risk) form, on a replacement cost basis, and provide coverage consistent with that required for the builder's risk insurance. The builder's risk insurance may terminate upon written confirmation of Owner's procurement of such property insurance.
- D. *Partial Occupancy or Use by Owner:* If Owner will occupy or use a portion or portions of the Work prior to Substantial Completion of all the Work, as provided in Paragraph 15.04, then Owner (directly, if it is the purchaser of the builder's risk policy, or through Contractor) will provide advance notice of such occupancy or use to the builder's risk insurer, and obtain an endorsement consenting to the continuation of coverage prior to commencing such partial occupancy or use.
- E. *Insurance of Other Property; Additional Insurance:* If the express insurance provisions of the Contract do not require or address the insurance of a property item or interest, then the entity or individual owning such property item will be responsible for insuring it. If Contractor elects to obtain other special insurance to be included in or supplement the builder's risk or property insurance policies provided under this Paragraph 6.04, it may do so at Contractor's expense.

6.05 *Property Losses; Subrogation*

- A. The builder's risk insurance policy purchased and maintained in accordance with Paragraph 6.04 (or an installation floater policy if authorized by the Supplementary Conditions), will contain provisions to the effect that in the event of payment of any loss or damage the insurer will have no rights of recovery against any insureds thereunder, or against Engineer or its consultants, or their officers, directors, members, partners, employees, agents, consultants, or subcontractors.
 - 1. Owner and Contractor waive all rights against each other and the respective officers, directors, members, partners, employees, agents, consultants, and subcontractors of each and any of them, for all losses and damages caused by, arising out of, or resulting from any of the perils, risks, or causes of loss covered by such policies and any other property insurance applicable to the Work; and, in addition, waive all such rights against Engineer, its consultants, all individuals or entities identified in the Supplementary Conditions as builder's risk or installation floater insureds, and the officers, directors, members, partners, employees, agents, consultants, and subcontractors of each and any of them, under such policies for losses and damages so caused.
 - 2. None of the above waivers extends to the rights that any party making such waiver may have to the proceeds of insurance held by Owner or Contractor as trustee or fiduciary, or otherwise payable under any policy so issued.
- B. Any property insurance policy maintained by Owner covering any loss, damage, or consequential loss to Owner's existing structures, buildings, or facilities in which any part of the Work will occur, or to which any part of the Work will attach or adjoin; to adjacent structures, buildings, or facilities of Owner; or to part or all of the completed or substantially completed Work, during partial occupancy or use pursuant to Paragraph 15.04, after Substantial Completion pursuant to Paragraph 15.03, or after final payment pursuant to

Paragraph 15.06, will contain provisions to the effect that in the event of payment of any loss or damage the insurer will have no rights of recovery against any insureds thereunder, or against Contractor, Subcontractors, or Engineer, or the officers, directors, members, partners, employees, agents, consultants, or subcontractors of each and any of them, and that the insured is allowed to waive the insurer's rights of subrogation in a written contract executed prior to the loss, damage, or consequential loss.

1. Owner waives all rights against Contractor, Subcontractors, and Engineer, and the officers, directors, members, partners, employees, agents, consultants and subcontractors of each and any of them, for all losses and damages caused by, arising out of, or resulting from fire or any of the perils, risks, or causes of loss covered by such policies.
- C. The waivers in this Paragraph 6.05 include the waiver of rights due to business interruption, loss of use, or other consequential loss extending beyond direct physical loss or damage to Owner's property or the Work caused by, arising out of, or resulting from fire or other insured peril, risk, or cause of loss.
- D. Contractor shall be responsible for assuring that each Subcontract contains provisions whereby the Subcontractor waives all rights against Owner, Contractor, all individuals or entities identified in the Supplementary Conditions as insureds, the Engineer and its consultants, and the officers, directors, members, partners, employees, agents, consultants, and subcontractors of each and any of them, for all losses and damages caused by, arising out of, relating to, or resulting from fire or other peril, risk, or cause of loss covered by builder's risk insurance, installation floater, and any other property insurance applicable to the Work.

6.06 *Receipt and Application of Property Insurance Proceeds*

- A. Any insured loss under the builder's risk and other policies of property insurance required by Paragraph 6.04 will be adjusted and settled with the named insured that purchased the policy. Such named insured shall act as fiduciary for the other insureds, and give notice to such other insureds that adjustment and settlement of a claim is in progress. Any other insured may state its position regarding a claim for insured loss in writing within 15 days after notice of such claim.
- B. Proceeds for such insured losses may be made payable by the insurer either jointly to multiple insureds, or to the named insured that purchased the policy in its own right and as fiduciary for other insureds, subject to the requirements of any applicable mortgage clause. A named insured receiving insurance proceeds under the builder's risk and other policies of insurance required by Paragraph 6.04 shall maintain such proceeds in a segregated account, and distribute such proceeds in accordance with such agreement as the parties in interest may reach, or as otherwise required under the dispute resolution provisions of this Contract or applicable Laws and Regulations.
- C. If no other special agreement is reached, Contractor shall repair or replace the damaged Work, using allocated insurance proceeds.

ARTICLE 7—CONTRACTOR’S RESPONSIBILITIES

7.01 *Contractor’s Means and Methods of Construction*

- A. Contractor shall be solely responsible for the means, methods, techniques, sequences, and procedures of construction.
- B. If the Contract Documents note, or Contractor determines, that professional engineering or other design services are needed to carry out Contractor’s responsibilities for construction means, methods, techniques, sequences, and procedures, or for Site safety, then Contractor shall cause such services to be provided by a properly licensed design professional, at Contractor’s expense. Such services are not Owner-delegated professional design services under this Contract, and neither Owner nor Engineer has any responsibility with respect to (1) Contractor’s determination of the need for such services, (2) the qualifications or licensing of the design professionals retained or employed by Contractor, (3) the performance of such services, or (4) any errors, omissions, or defects in such services.

See SC-7.01C

7.02 *Supervision and Superintendence*

- A. Contractor shall supervise, inspect, and direct the Work competently and efficiently, devoting such attention thereto and applying such skills and expertise as may be necessary to perform the Work in accordance with the Contract Documents.
- B. At all times during the progress of the Work, Contractor shall assign a competent resident superintendent who will not be replaced without written notice to Owner and Engineer except under extraordinary circumstances.

7.03 *Labor; Working Hours*

- A. Contractor shall provide competent, suitably qualified personnel to survey and lay out the Work and perform construction as required by the Contract Documents. Contractor shall maintain good discipline and order at the Site.
- B. Contractor shall be fully responsible to Owner and Engineer for all acts and omissions of Contractor’s employees; of Suppliers and Subcontractors, and their employees; and of any other individuals or entities performing or furnishing any of the Work, just as Contractor is responsible for Contractor’s own acts and omissions.
- C. Except as otherwise required for the safety or protection of persons or the Work or property at the Site or adjacent thereto, and except as otherwise stated in the Contract Documents, all Work at the Site will be performed during regular working hours, Monday through Friday. Contractor will not perform Work on a Saturday, Sunday, or any legal holiday. Contractor may perform Work outside regular working hours or on Saturdays, Sundays, or legal holidays only with Owner’s written consent, which will not be unreasonably withheld.

7.04 *Services, Materials, and Equipment*

- A. Unless otherwise specified in the Contract Documents, Contractor shall provide and assume full responsibility for all services, materials, equipment, labor, transportation, construction equipment and machinery, tools, appliances, fuel, power, light, heat, telephone, water, sanitary facilities, temporary facilities, and all other facilities and incidentals necessary for the

performance, testing, start up, and completion of the Work, whether or not such items are specifically called for in the Contract Documents.

- B. All materials and equipment incorporated into the Work must be new and of good quality, except as otherwise provided in the Contract Documents. All special warranties and guarantees required by the Specifications will expressly run to the benefit of Owner. If required by Engineer, Contractor shall furnish satisfactory evidence (including reports of required tests) as to the source, kind, and quality of materials and equipment.
- C. All materials and equipment must be stored, applied, installed, connected, erected, protected, used, cleaned, and conditioned in accordance with instructions of the applicable Supplier, except as otherwise may be provided in the Contract Documents.

See SC-7.04

7.05 "Or Equals"

- A. *Contractor's Request; Governing Criteria:* Whenever an item of equipment or material is specified or described in the Contract Documents by using the names of one or more proprietary items or specific Suppliers, the Contract Price has been based upon Contractor furnishing such item as specified. The specification or description of such an item is intended to establish the type, function, appearance, and quality required. Unless the specification or description contains or is followed by words reading that no like, equivalent, or "or equal" item is permitted, Contractor may request that Engineer authorize the use of other items of equipment or material, or items from other proposed Suppliers, under the circumstances described below.
 - 1. If Engineer in its sole discretion determines that an item of equipment or material proposed by Contractor is functionally equal to that named and sufficiently similar so that no change in related Work will be required, Engineer will deem it an "or equal" item. For the purposes of this paragraph, a proposed item of equipment or material will be considered functionally equal to an item so named if:
 - a. in the exercise of reasonable judgment Engineer determines that the proposed item:
 - 1) is at least equal in materials of construction, quality, durability, appearance, strength, and design characteristics;
 - 2) will reliably perform at least equally well the function and achieve the results imposed by the design concept of the completed Project as a functioning whole;
 - 3) has a proven record of performance and availability of responsive service; and
 - 4) is not objectionable to Owner.
 - b. Contractor certifies that, if the proposed item is approved and incorporated into the Work:
 - 1) there will be no increase in cost to the Owner or increase in Contract Times; and
 - 2) the item will conform substantially to the detailed requirements of the item named in the Contract Documents.
- B. *Contractor's Expense:* Contractor shall provide all data in support of any proposed "or equal" item at Contractor's expense.

- C. *Engineer's Evaluation and Determination*: Engineer will be allowed a reasonable time to evaluate each "or-equal" request. Engineer may require Contractor to furnish additional data about the proposed "or-equal" item. Engineer will be the sole judge of acceptability. No "or-equal" item will be ordered, furnished, installed, or utilized until Engineer's review is complete and Engineer determines that the proposed item is an "or-equal," which will be evidenced by an approved Shop Drawing or other written communication. Engineer will advise Contractor in writing of any negative determination.
- D. *Effect of Engineer's Determination*: Neither approval nor denial of an "or-equal" request will result in any change in Contract Price. The Engineer's denial of an "or-equal" request will be final and binding, and may not be reversed through an appeal under any provision of the Contract.
- E. *Treatment as a Substitution Request*: If Engineer determines that an item of equipment or material proposed by Contractor does not qualify as an "or-equal" item, Contractor may request that Engineer consider the item a proposed substitute pursuant to Paragraph 7.06.

7.06 *Substitutes*

- A. *Contractor's Request; Governing Criteria*: Unless the specification or description of an item of equipment or material required to be furnished under the Contract Documents contains or is followed by words reading that no substitution is permitted, Contractor may request that Engineer authorize the use of other items of equipment or material under the circumstances described below. To the extent possible such requests must be made before commencement of related construction at the Site.
 1. Contractor shall submit sufficient information as provided below to allow Engineer to determine if the item of material or equipment proposed is functionally equivalent to that named and an acceptable substitute therefor. Engineer will not accept requests for review of proposed substitute items of equipment or material from anyone other than Contractor.
 2. The requirements for review by Engineer will be as set forth in Paragraph 7.06.B, as supplemented by the Specifications, and as Engineer may decide is appropriate under the circumstances.
 3. Contractor shall make written application to Engineer for review of a proposed substitute item of equipment or material that Contractor seeks to furnish or use. The application:
 - a. will certify that the proposed substitute item will:
 - 1) perform adequately the functions and achieve the results called for by the general design;
 - 2) be similar in substance to the item specified; and
 - 3) be suited to the same use as the item specified.
 - b. will state:
 - 1) the extent, if any, to which the use of the proposed substitute item will necessitate a change in Contract Times;
 - 2) whether use of the proposed substitute item in the Work will require a change in any of the Contract Documents (or in the provisions of any other direct contract

with Owner for other work on the Project) to adapt the design to the proposed substitute item; and

3) whether incorporation or use of the proposed substitute item in connection with the Work is subject to payment of any license fee or royalty.

c. will identify:

1) all variations of the proposed substitute item from the item specified; and

2) available engineering, sales, maintenance, repair, and replacement services.

d. will contain an itemized estimate of all costs or credits that will result directly or indirectly from use of such substitute item, including but not limited to changes in Contract Price, shared savings, costs of redesign, and claims of other contractors affected by any resulting change.

B. *Engineer's Evaluation and Determination*: Engineer will be allowed a reasonable time to evaluate each substitute request, and to obtain comments and direction from Owner. Engineer may require Contractor to furnish additional data about the proposed substitute item. Engineer will be the sole judge of acceptability. No substitute will be ordered, furnished, installed, or utilized until Engineer's review is complete and Engineer determines that the proposed item is an acceptable substitute. Engineer's determination will be evidenced by a Field Order or a proposed Change Order accounting for the substitution itself and all related impacts, including changes in Contract Price or Contract Times. Engineer will advise Contractor in writing of any negative determination.

C. *Special Guarantee*: Owner may require Contractor to furnish at Contractor's expense a special performance guarantee or other surety with respect to any substitute.

D. *Reimbursement of Engineer's Cost*: Engineer will record Engineer's costs in evaluating a substitute proposed or submitted by Contractor. Whether or not Engineer approves a substitute so proposed or submitted by Contractor, Contractor shall reimburse Owner for the reasonable charges of Engineer for evaluating each such proposed substitute. Contractor shall also reimburse Owner for the reasonable charges of Engineer for making changes in the Contract Documents (or in the provisions of any other direct contract with Owner) resulting from the acceptance of each proposed substitute.

E. *Contractor's Expense*: Contractor shall provide all data in support of any proposed substitute at Contractor's expense.

F. *Effect of Engineer's Determination*: If Engineer approves the substitution request, Contractor shall execute the proposed Change Order and proceed with the substitution. The Engineer's denial of a substitution request will be final and binding, and may not be reversed through an appeal under any provision of the Contract. Contractor may challenge the scope of reimbursement costs imposed under Paragraph 7.06.D, by timely submittal of a Change Proposal.

7.07 *Concerning Subcontractors and Suppliers*

A. Contractor may retain Subcontractors and Suppliers for the performance of parts of the Work. Such Subcontractors and Suppliers must be acceptable to Owner. The Contractor's retention of a Subcontractor or Supplier for the performance of parts of the Work will not relieve

Contractor's obligation to Owner to perform and complete the Work in accordance with the Contract Documents.

See SC-7.07

- B. Contractor shall retain specific Subcontractors and Suppliers for the performance of designated parts of the Work if required by the Contract to do so.
- C. Subsequent to the submittal of Contractor's Bid or final negotiation of the terms of the Contract, Owner may not require Contractor to retain any Subcontractor or Supplier to furnish or perform any of the Work against which Contractor has reasonable objection.
- D. Prior to entry into any binding subcontract or purchase order, Contractor shall submit to Owner the identity of the proposed Subcontractor or Supplier (unless Owner has already deemed such proposed Subcontractor or Supplier acceptable during the bidding process or otherwise). Such proposed Subcontractor or Supplier shall be deemed acceptable to Owner unless Owner raises a substantive, reasonable objection within 5 days.
- E. Owner may require the replacement of any Subcontractor or Supplier. Owner also may require Contractor to retain specific replacements; provided, however, that Owner may not require a replacement to which Contractor has a reasonable objection. If Contractor has submitted the identity of certain Subcontractors or Suppliers for acceptance by Owner, and Owner has accepted it (either in writing or by failing to make written objection thereto), then Owner may subsequently revoke the acceptance of any such Subcontractor or Supplier so identified solely on the basis of substantive, reasonable objection after due investigation. Contractor shall submit an acceptable replacement for the rejected Subcontractor or Supplier.
- F. If Owner requires the replacement of any Subcontractor or Supplier retained by Contractor to perform any part of the Work, then Contractor shall be entitled to an adjustment in Contract Price or Contract Times, with respect to the replacement; and Contractor shall initiate a Change Proposal for such adjustment within 30 days of Owner's requirement of replacement.
- G. No acceptance by Owner of any such Subcontractor or Supplier, whether initially or as a replacement, will constitute a waiver of the right of Owner to the completion of the Work in accordance with the Contract Documents.
- H. On a monthly basis, Contractor shall submit to Engineer a complete list of all Subcontractors and Suppliers having a direct contract with Contractor, and of all other Subcontractors and Suppliers known to Contractor at the time of submittal.
- I. Contractor shall be solely responsible for scheduling and coordinating the work of Subcontractors and Suppliers.
- J. The divisions and sections of the Specifications and the identifications of any Drawings do not control Contractor in dividing the Work among Subcontractors or Suppliers, or in delineating the Work to be performed by any specific trade.
- K. All Work performed for Contractor by a Subcontractor or Supplier must be pursuant to an appropriate contractual agreement that specifically binds the Subcontractor or Supplier to the applicable terms and conditions of the Contract for the benefit of Owner and Engineer.

- L. Owner may furnish to any Subcontractor or Supplier, to the extent practicable, information about amounts paid to Contractor for Work performed for Contractor by the Subcontractor or Supplier.
- M. Contractor shall restrict all Subcontractors and Suppliers from communicating with Engineer or Owner, except through Contractor or in case of an emergency, or as otherwise expressly allowed in this Contract.

7.08 *Patent Fees and Royalties*

- A. Contractor shall pay all license fees and royalties and assume all costs incident to the use in the performance of the Work or the incorporation in the Work of any invention, design, process, product, or device which is the subject of patent rights or copyrights held by others. If an invention, design, process, product, or device is specified in the Contract Documents for use in the performance of the Work and if, to the actual knowledge of Owner or Engineer, its use is subject to patent rights or copyrights calling for the payment of any license fee or royalty to others, the existence of such rights will be disclosed in the Contract Documents.
- B. To the fullest extent permitted by Laws and Regulations, Owner shall indemnify and hold harmless Contractor, and its officers, directors, members, partners, employees, agents, consultants, and subcontractors, from and against all claims, costs, losses, and damages (including but not limited to all fees and charges of engineers, architects, attorneys, and other professionals, and all court or arbitration or other dispute resolution costs) arising out of or relating to any infringement of patent rights or copyrights incident to the use in the performance of the Work or resulting from the incorporation in the Work of any invention, design, process, product, or device specified in the Contract Documents, but not identified as being subject to payment of any license fee or royalty to others required by patent rights or copyrights.
- C. To the fullest extent permitted by Laws and Regulations, Contractor shall indemnify and hold harmless Owner and Engineer, and the officers, directors, members, partners, employees, agents, consultants and subcontractors of each and any of them, from and against all claims, costs, losses, and damages (including but not limited to all fees and charges of engineers, architects, attorneys, and other professionals and all court or arbitration or other dispute resolution costs) arising out of or relating to any infringement of patent rights or copyrights incident to the use in the performance of the Work or resulting from the incorporation in the Work of any invention, design, process, product, or device not specified in the Contract Documents.

7.09 *Permits*

- A. Unless otherwise provided in the Contract Documents, Contractor shall obtain and pay for all construction permits, licenses, and certificates of occupancy. Owner shall assist Contractor, when necessary, in obtaining such permits and licenses. Contractor shall pay all governmental charges and inspection fees necessary for the prosecution of the Work which are applicable at the time of the submission of Contractor's Bid (or when Contractor became bound under a negotiated contract). Owner shall pay all charges of utility owners for connections for providing permanent service to the Work.

See SC-7.09

7.10 *Taxes*

- A. Contractor shall pay all sales, consumer, use, and other similar taxes required to be paid by Contractor in accordance with the Laws and Regulations of the place of the Project which are applicable during the performance of the Work.

7.11 *Laws and Regulations*

- A. Contractor shall give all notices required by and shall comply with all Laws and Regulations applicable to the performance of the Work. Neither Owner nor Engineer shall be responsible for monitoring Contractor's compliance with any Laws or Regulations.
- B. If Contractor performs any Work or takes any other action knowing or having reason to know that it is contrary to Laws or Regulations, Contractor shall bear all resulting costs and losses, and shall indemnify and hold harmless Owner and Engineer, and the officers, directors, members, partners, employees, agents, consultants, and subcontractors of each and any of them, from and against all claims, costs, losses, and damages (including but not limited to all fees and charges of engineers, architects, attorneys, and other professionals and all court or arbitration or other dispute resolution costs) arising out of or relating to such Work or other action. It is not Contractor's responsibility to make certain that the Work described in the Contract Documents is in accordance with Laws and Regulations, but this does not relieve Contractor of its obligations under Paragraph 3.03.
- C. Owner or Contractor may give written notice to the other party of any changes after the submission of Contractor's Bid (or after the date when Contractor became bound under a negotiated contract) in Laws or Regulations having an effect on the cost or time of performance of the Work, including but not limited to changes in Laws or Regulations having an effect on procuring permits and on sales, use, value-added, consumption, and other similar taxes. If Owner and Contractor are unable to agree on entitlement to or on the amount or extent, if any, of any adjustment in Contract Price or Contract Times resulting from such changes, then within 30 days of such written notice Contractor may submit a Change Proposal, or Owner may initiate a Claim.

See SC-7.11

7.12 *Record Documents*

- A. Contractor shall maintain in a safe place at the Site one printed record copy of all Drawings, Specifications, Addenda, Change Orders, Work Change Directives, Field Orders, written interpretations and clarifications, and approved Shop Drawings. Contractor shall keep such record documents in good order and annotate them to show changes made during construction. These record documents, together with all approved Samples, will be available to Engineer for reference. Upon completion of the Work, Contractor shall deliver these record documents to Engineer.

7.13 *Safety and Protection*

- A. Contractor shall be solely responsible for initiating, maintaining, and supervising all safety precautions and programs in connection with the Work. Such responsibility does not relieve Subcontractors of their responsibility for the safety of persons or property in the performance of their work, nor for compliance with applicable safety Laws and Regulations.

- B. Contractor shall designate a qualified and experienced safety representative whose duties and responsibilities are the prevention of Work-related accidents and the maintenance and supervision of safety precautions and programs.
- C. Contractor shall take all necessary precautions for the safety of, and shall provide the necessary protection to prevent damage, injury, or loss to:
 - 1. all persons on the Site or who may be affected by the Work;
 - 2. all the Work and materials and equipment to be incorporated therein, whether in storage on or off the Site; and
 - 3. other property at the Site or adjacent thereto, including trees, shrubs, lawns, walks, pavements, roadways, structures, other work in progress, utilities, and Underground Facilities not designated for removal, relocation, or replacement in the course of construction.
- D. All damage, injury, or loss to any property referred to in Paragraph 7.13.C.2 or 7.13.C.3 caused, directly or indirectly, in whole or in part, by Contractor, any Subcontractor, Supplier, or any other individual or entity directly or indirectly employed by any of them to perform any of the Work, or anyone for whose acts any of them may be liable, shall be remedied by Contractor at its expense (except damage or loss attributable to the fault of Drawings or Specifications or to the acts or omissions of Owner or Engineer or anyone employed by any of them, or anyone for whose acts any of them may be liable, and not attributable, directly or indirectly, in whole or in part, to the fault or negligence of Contractor or any Subcontractor, Supplier, or other individual or entity directly or indirectly employed by any of them).
- E. Contractor shall comply with all applicable Laws and Regulations relating to the safety of persons or property, or to the protection of persons or property from damage, injury, or loss; and shall erect and maintain all necessary safeguards for such safety and protection.
- F. Contractor shall notify Owner; the owners of adjacent property; the owners of Underground Facilities and other utilities (if the identity of such owners is known to Contractor); and other contractors and utility owners performing work at or adjacent to the Site, in writing, when Contractor knows that prosecution of the Work may affect them, and shall cooperate with them in the protection, removal, relocation, and replacement of their property or work in progress.
- G. Contractor shall comply with the applicable requirements of Owner's safety programs, if any. Any Owner's safety programs that are applicable to the Work are identified or included in the Supplementary Conditions or Specifications.

See SC-7.13

- H. Contractor shall inform Owner and Engineer of the specific requirements of Contractor's safety program with which Owner's and Engineer's employees and representatives must comply while at the Site.
- I. Contractor's duties and responsibilities for safety and protection will continue until all the Work is completed, Engineer has issued a written notice to Owner and Contractor in accordance with Paragraph 15.06.C that the Work is acceptable, and Contractor has left the Site (except as otherwise expressly provided in connection with Substantial Completion).

- J. Contractor's duties and responsibilities for safety and protection will resume whenever Contractor or any Subcontractor or Supplier returns to the Site to fulfill warranty or correction obligations, or to conduct other tasks arising from the Contract Documents.

7.14 *Hazard Communication Programs*

- A. Contractor shall be responsible for coordinating any exchange of safety data sheets (formerly known as material safety data sheets) or other hazard communication information required to be made available to or exchanged between or among employers at the Site in accordance with Laws or Regulations.

7.15 *Emergencies*

- A. In emergencies affecting the safety or protection of persons or the Work or property at the Site or adjacent thereto, Contractor is obligated to act to prevent damage, injury, or loss. Contractor shall give Engineer prompt written notice if Contractor believes that any significant changes in the Work or variations from the Contract Documents have been caused by an emergency, or are required as a result of Contractor's response to an emergency. If Engineer determines that a change in the Contract Documents is required because of an emergency or Contractor's response, a Work Change Directive or Change Order will be issued.

7.16 *Submittals*

A. *Shop Drawing and Sample Requirements*

1. Before submitting a Shop Drawing or Sample, Contractor shall:
 - a. review and coordinate the Shop Drawing or Sample with other Shop Drawings and Samples and with the requirements of the Work and the Contract Documents;
 - b. determine and verify:
 - 1) all field measurements, quantities, dimensions, specified performance and design criteria, installation requirements, materials, catalog numbers, and similar information with respect to the Submittal;
 - 2) the suitability of all materials and equipment offered with respect to the indicated application, fabrication, shipping, handling, storage, assembly, and installation pertaining to the performance of the Work; and
 - 3) all information relative to Contractor's responsibilities for means, methods, techniques, sequences, and procedures of construction, and safety precautions and programs incident thereto;
 - c. confirm that the Submittal is complete with respect to all related data included in the Submittal.
2. Each Shop Drawing or Sample must bear a stamp or specific written certification that Contractor has satisfied Contractor's obligations under the Contract Documents with respect to Contractor's review of that Submittal, and that Contractor approves the Submittal.
3. With each Shop Drawing or Sample, Contractor shall give Engineer specific written notice of any variations that the Submittal may have from the requirements of the Contract Documents. This notice must be set forth in a written communication separate from the

Submittal; and, in addition, in the case of a Shop Drawing by a specific notation made on the Shop Drawing itself.

B. *Submittal Procedures for Shop Drawings and Samples:* Contractor shall label and submit Shop Drawings and Samples to Engineer for review and approval in accordance with the accepted Schedule of Submittals.

1. *Shop Drawings*

- a. Contractor shall submit the number of copies required in the Specifications.
- b. Data shown on the Shop Drawings must be complete with respect to quantities, dimensions, specified performance and design criteria, materials, and similar data to show Engineer the services, materials, and equipment Contractor proposes to provide, and to enable Engineer to review the information for the limited purposes required by Paragraph 7.16.C.

2. *Samples*

- a. Contractor shall submit the number of Samples required in the Specifications.
- b. Contractor shall clearly identify each Sample as to material, Supplier, pertinent data such as catalog numbers, the use for which intended and other data as Engineer may require to enable Engineer to review the Submittal for the limited purposes required by Paragraph 7.16.C.

3. Where a Shop Drawing or Sample is required by the Contract Documents or the Schedule of Submittals, any related Work performed prior to Engineer's review and approval of the pertinent submittal will be at the sole expense and responsibility of Contractor.

C. *Engineer's Review of Shop Drawings and Samples*

1. Engineer will provide timely review of Shop Drawings and Samples in accordance with the accepted Schedule of Submittals. Engineer's review and approval will be only to determine if the items covered by the Submittals will, after installation or incorporation in the Work, comply with the requirements of the Contract Documents, and be compatible with the design concept of the completed Project as a functioning whole as indicated by the Contract Documents.
2. Engineer's review and approval will not extend to means, methods, techniques, sequences, or procedures of construction, or to safety precautions or programs incident thereto.
3. Engineer's review and approval of a separate item as such will not indicate approval of the assembly in which the item functions.
4. Engineer's review and approval of a Shop Drawing or Sample will not relieve Contractor from responsibility for any variation from the requirements of the Contract Documents unless Contractor has complied with the requirements of Paragraph 7.16.A.3 and Engineer has given written approval of each such variation by specific written notation thereof incorporated in or accompanying the Shop Drawing or Sample. Engineer will document any such approved variation from the requirements of the Contract Documents in a Field Order or other appropriate Contract modification.

5. Engineer's review and approval of a Shop Drawing or Sample will not relieve Contractor from responsibility for complying with the requirements of Paragraphs 7.16.A and B.
6. Engineer's review and approval of a Shop Drawing or Sample, or of a variation from the requirements of the Contract Documents, will not, under any circumstances, change the Contract Times or Contract Price, unless such changes are included in a Change Order.
7. Neither Engineer's receipt, review, acceptance, or approval of a Shop Drawing or Sample will result in such item becoming a Contract Document.
8. Contractor shall perform the Work in compliance with the requirements and commitments set forth in approved Shop Drawings and Samples, subject to the provisions of Paragraph 7.16.C.4.

D. Resubmittal Procedures for Shop Drawings and Samples

1. Contractor shall make corrections required by Engineer and shall return the required number of corrected copies of Shop Drawings and submit, as required, new Samples for review and approval. Contractor shall direct specific attention in writing to revisions other than the corrections called for by Engineer on previous Submittals.
2. Contractor shall furnish required Shop Drawing and Sample submittals with sufficient information and accuracy to obtain required approval of an item with no more than two resubmittals. Engineer will record Engineer's time for reviewing a third or subsequent resubmittal of a Shop Drawing or Sample, and Contractor shall be responsible for Engineer's charges to Owner for such time. Owner may impose a set-off against payments due Contractor to secure reimbursement for such charges.
3. If Contractor requests a change of a previously approved Shop Drawing or Sample, Contractor shall be responsible for Engineer's charges to Owner for its review time, and Owner may impose a set-off against payments due Contractor to secure reimbursement for such charges, unless the need for such change is beyond the control of Contractor.

E. Submittals Other than Shop Drawings, Samples, and Owner-Delegated Designs

1. The following provisions apply to all Submittals other than Shop Drawings, Samples, and Owner-delegated designs:
 - a. Contractor shall submit all such Submittals to the Engineer in accordance with the Schedule of Submittals and pursuant to the applicable terms of the Contract Documents.
 - b. Engineer will provide timely review of all such Submittals in accordance with the Schedule of Submittals and return such Submittals with a notation of either Accepted or Not Accepted. Any such Submittal that is not returned within the time established in the Schedule of Submittals will be deemed accepted.
 - c. Engineer's review will be only to determine if the Submittal is acceptable under the requirements of the Contract Documents as to general form and content of the Submittal.
 - d. If any such Submittal is not accepted, Contractor shall confer with Engineer regarding the reason for the non-acceptance, and resubmit an acceptable document.

2. Procedures for the submittal and acceptance of the Progress Schedule, the Schedule of Submittals, and the Schedule of Values are set forth in Paragraphs 2.03, 2.04, and 2.05.
- F. Owner-delegated Designs: Submittals pursuant to Owner-delegated designs are governed by the provisions of Paragraph 7.19.

7.17 *Contractor's General Warranty and Guarantee*

- A. Contractor warrants and guarantees to Owner that all Work will be in accordance with the Contract Documents and will not be defective. Engineer is entitled to rely on Contractor's warranty and guarantee.
- B. Owner's rights under this warranty and guarantee are in addition to, and are not limited by, Owner's rights under the correction period provisions of Paragraph 15.08. The time in which Owner may enforce its warranty and guarantee rights under this Paragraph 7.17 is limited only by applicable Laws and Regulations restricting actions to enforce such rights; provided, however, that after the end of the correction period under Paragraph 15.08:
1. Owner shall give Contractor written notice of any defective Work within 60 days of the discovery that such Work is defective; and
 2. Such notice will be deemed the start of an event giving rise to a Claim under Paragraph 12.01.B, such that any related Claim must be brought within 30 days of the notice.
- C. Contractor's warranty and guarantee hereunder excludes defects or damage caused by:
1. abuse, or improper modification, maintenance, or operation, by persons other than Contractor, Subcontractors, Suppliers, or any other individual or entity for whom Contractor is responsible; or
 2. normal wear and tear under normal usage.
- D. Contractor's obligation to perform and complete the Work in accordance with the Contract Documents is absolute. None of the following will constitute an acceptance of Work that is not in accordance with the Contract Documents, a release of Contractor's obligation to perform the Work in accordance with the Contract Documents, or a release of Owner's warranty and guarantee rights under this Paragraph 7.17:
1. Observations by Engineer;
 2. Recommendation by Engineer or payment by Owner of any progress or final payment;
 3. The issuance of a certificate of Substantial Completion by Engineer or any payment related thereto by Owner;
 4. Use or occupancy of the Work or any part thereof by Owner;
 5. Any review and approval of a Shop Drawing or Sample submittal;
 6. The issuance of a notice of acceptability by Engineer;
 7. The end of the correction period established in Paragraph 15.08;
 8. Any inspection, test, or approval by others; or
 9. Any correction of defective Work by Owner.

- E. If the Contract requires the Contractor to accept the assignment of a contract entered into by Owner, then the specific warranties, guarantees, and correction obligations contained in the assigned contract will govern with respect to Contractor's performance obligations to Owner for the Work described in the assigned contract.

7.18 *Indemnification*

- A. To the fullest extent permitted by Laws and Regulations, and in addition to any other obligations of Contractor under the Contract or otherwise, Contractor shall indemnify and hold harmless Owner and Engineer, and the officers, directors, members, partners, employees, agents, consultants and subcontractors of each and any of them, from losses, damages, costs, and judgments (including but not limited to all fees and charges of engineers, architects, attorneys, and other professionals, and all court or arbitration or other dispute resolution costs) arising from third-party claims or actions relating to or resulting from the performance or furnishing of the Work, provided that any such claim, action, loss, cost, judgment or damage is attributable to bodily injury, sickness, disease, or death, or to damage to or destruction of tangible property (other than the Work itself), including the loss of use resulting therefrom, but only to the extent caused by any negligent act or omission of Contractor, any Subcontractor, any Supplier, or any individual or entity directly or indirectly employed by any of them to perform any of the Work, or anyone for whose acts any of them may be liable.
- B. In any and all claims against Owner or Engineer, or any of their officers, directors, members, partners, employees, agents, consultants, or subcontractors, by any employee (or the survivor or personal representative of such employee) of Contractor, any Subcontractor, any Supplier, or any individual or entity directly or indirectly employed by any of them to perform any of the Work, or anyone for whose acts any of them may be liable, the indemnification obligation under Paragraph 7.18.A will not be limited in any way by any limitation on the amount or type of damages, compensation, or benefits payable by or for Contractor or any such Subcontractor, Supplier, or other individual or entity under workers' compensation acts, disability benefit acts, or other employee benefit acts.

See SC-7.18

7.19 *Delegation of Professional Design Services*

- A. Owner may require Contractor to provide professional design services for a portion of the Work by express delegation in the Contract Documents. Such delegation will specify the performance and design criteria that such services must satisfy, and the Submittals that Contractor must furnish to Engineer with respect to the Owner-delegated design.
- B. Contractor shall cause such Owner-delegated professional design services to be provided pursuant to the professional standard of care by a properly licensed design professional, whose signature and seal must appear on all drawings, calculations, specifications, certifications, and Submittals prepared by such design professional. Such design professional must issue all certifications of design required by Laws and Regulations.
- C. If a Shop Drawing or other Submittal related to the Owner-delegated design is prepared by Contractor, a Subcontractor, or others for submittal to Engineer, then such Shop Drawing or other Submittal must bear the written approval of Contractor's design professional when submitted by Contractor to Engineer.

- D. Owner and Engineer shall be entitled to rely upon the adequacy, accuracy, and completeness of the services, certifications, and approvals performed or provided by the design professionals retained or employed by Contractor under an Owner-delegated design, subject to the professional standard of care and the performance and design criteria stated in the Contract Documents.
- E. Pursuant to this Paragraph 7.19, Engineer's review, approval, and other determinations regarding design drawings, calculations, specifications, certifications, and other Submittals furnished by Contractor pursuant to an Owner-delegated design will be only for the following limited purposes:
 - 1. Checking for conformance with the requirements of this Paragraph 7.19;
 - 2. Confirming that Contractor (through its design professionals) has used the performance and design criteria specified in the Contract Documents; and
 - 3. Establishing that the design furnished by Contractor is consistent with the design concept expressed in the Contract Documents.
- F. Contractor shall not be responsible for the adequacy of performance or design criteria specified by Owner or Engineer.
- G. Contractor is not required to provide professional services in violation of applicable Laws and Regulations.

ARTICLE 8—OTHER WORK AT THE SITE

8.01 *Other Work*

- A. In addition to and apart from the Work under the Contract Documents, the Owner may perform other work at or adjacent to the Site. Such other work may be performed by Owner's employees, or through contracts between the Owner and third parties. Owner may also arrange to have third-party utility owners perform work on their utilities and facilities at or adjacent to the Site.
- B. If Owner performs other work at or adjacent to the Site with Owner's employees, or through contracts for such other work, then Owner shall give Contractor written notice thereof prior to starting any such other work. If Owner has advance information regarding the start of any third-party utility work that Owner has arranged to take place at or adjacent to the Site, Owner shall provide such information to Contractor.
- C. Contractor shall afford proper and safe access to the Site to each contractor that performs such other work, each utility owner performing other work, and Owner, if Owner is performing other work with Owner's employees, and provide a reasonable opportunity for the introduction and storage of materials and equipment and the execution of such other work.
- D. Contractor shall do all cutting, fitting, and patching of the Work that may be required to properly connect or otherwise make its several parts come together and properly integrate with such other work. Contractor shall not endanger any work of others by cutting, excavating, or otherwise altering such work; provided, however, that Contractor may cut or alter others' work with the written consent of Engineer and the others whose work will be affected.

- E. If the proper execution or results of any part of Contractor's Work depends upon work performed by others, Contractor shall inspect such other work and promptly report to Engineer in writing any delays, defects, or deficiencies in such other work that render it unavailable or unsuitable for the proper execution and results of Contractor's Work. Contractor's failure to so report will constitute an acceptance of such other work as fit and proper for integration with Contractor's Work except for latent defects and deficiencies in such other work.
- F. The provisions of this article are not applicable to work that is performed by third-party utilities or other third-party entities without a contract with Owner, or that is performed without having been arranged by Owner. If such work occurs, then any related delay, disruption, or interference incurred by Contractor is governed by the provisions of Paragraph 4.05.C.3.

8.02 *Coordination*

- A. If Owner intends to contract with others for the performance of other work at or adjacent to the Site, to perform other work at or adjacent to the Site with Owner's employees, or to arrange to have utility owners perform work at or adjacent to the Site, the following will be set forth in the Supplementary Conditions or provided to Contractor prior to the start of any such other work:
 - 1. The identity of the individual or entity that will have authority and responsibility for coordination of the activities among the various contractors;
 - 2. An itemization of the specific matters to be covered by such authority and responsibility; and
 - 3. The extent of such authority and responsibilities.
- B. Unless otherwise provided in the Supplementary Conditions, Owner shall have sole authority and responsibility for such coordination.

8.03 *Legal Relationships*

- A. If, in the course of performing other work for Owner at or adjacent to the Site, the Owner's employees, any other contractor working for Owner, or any utility owner that Owner has arranged to perform work, causes damage to the Work or to the property of Contractor or its Subcontractors, or delays, disrupts, interferes with, or increases the scope or cost of the performance of the Work, through actions or inaction, then Contractor shall be entitled to an equitable adjustment in the Contract Price or the Contract Times. Contractor must submit any Change Proposal seeking an equitable adjustment in the Contract Price or the Contract Times under this paragraph within 30 days of the damaging, delaying, disrupting, or interfering event. The entitlement to, and extent of, any such equitable adjustment will take into account information (if any) regarding such other work that was provided to Contractor in the Contract Documents prior to the submittal of the Bid or the final negotiation of the terms of the Contract, and any remedies available to Contractor under Laws or Regulations concerning utility action or inaction. When applicable, any such equitable adjustment in Contract Price will be conditioned on Contractor assigning to Owner all Contractor's rights against such other contractor or utility owner with respect to the damage, delay, disruption, or interference that is the subject of the adjustment. Contractor's entitlement to an adjustment of the Contract Times or Contract Price is subject to the provisions of Paragraphs 4.05.D and 4.05.E.

- B. Contractor shall take reasonable and customary measures to avoid damaging, delaying, disrupting, or interfering with the work of Owner, any other contractor, or any utility owner performing other work at or adjacent to the Site.
 - 1. If Contractor fails to take such measures and as a result damages, delays, disrupts, or interferes with the work of any such other contractor or utility owner, then Owner may impose a set-off against payments due Contractor, and assign to such other contractor or utility owner the Owner's contractual rights against Contractor with respect to the breach of the obligations set forth in this Paragraph 8.03.B.
 - 2. When Owner is performing other work at or adjacent to the Site with Owner's employees, Contractor shall be liable to Owner for damage to such other work, and for the reasonable direct delay, disruption, and interference costs incurred by Owner as a result of Contractor's failure to take reasonable and customary measures with respect to Owner's other work. In response to such damage, delay, disruption, or interference, Owner may impose a set-off against payments due Contractor.
- C. If Contractor damages, delays, disrupts, or interferes with the work of any other contractor, or any utility owner performing other work at or adjacent to the Site, through Contractor's failure to take reasonable and customary measures to avoid such impacts, or if any claim arising out of Contractor's actions, inactions, or negligence in performance of the Work at or adjacent to the Site is made by any such other contractor or utility owner against Contractor, Owner, or Engineer, then Contractor shall (1) promptly attempt to settle the claim as to all parties through negotiations with such other contractor or utility owner, or otherwise resolve the claim by arbitration or other dispute resolution proceeding or at law, and (2) indemnify and hold harmless Owner and Engineer, and the officers, directors, members, partners, employees, agents, consultants and subcontractors of each and any of them from and against any such claims, and against all costs, losses, and damages (including but not limited to all fees and charges of engineers, architects, attorneys, and other professionals and all court or arbitration or other dispute resolution costs) arising out of or relating to such damage, delay, disruption, or interference.

ARTICLE 9—OWNER'S RESPONSIBILITIES

9.01 *Communications to Contractor*

- A. Except as otherwise provided in these General Conditions, Owner shall issue all communications to Contractor through Engineer.

9.02 *Replacement of Engineer*

- A. Owner may at its discretion appoint an engineer to replace Engineer, provided Contractor makes no reasonable objection to the replacement engineer. The replacement engineer's status under the Contract Documents will be that of the former Engineer.

9.03 *Furnish Data*

- A. Owner shall promptly furnish the data required of Owner under the Contract Documents.

9.04 *Pay When Due*

- A. Owner shall make payments to Contractor when they are due as provided in the Agreement.

- 9.05 *Lands and Easements; Reports, Tests, and Drawings*
- A. Owner's duties with respect to providing lands and easements are set forth in Paragraph 5.01.
 - B. Owner's duties with respect to providing engineering surveys to establish reference points are set forth in Paragraph 4.03.
 - C. Article 5 refers to Owner's identifying and making available to Contractor copies of reports of explorations and tests of conditions at the Site, and drawings of physical conditions relating to existing surface or subsurface structures at the Site.
- 9.06 *Insurance*
- A. Owner's responsibilities, if any, with respect to purchasing and maintaining liability and property insurance are set forth in Article 6.
- 9.07 *Change Orders*
- A. Owner's responsibilities with respect to Change Orders are set forth in Article 11.
- 9.08 *Inspections, Tests, and Approvals*
- A. Owner's responsibility with respect to certain inspections, tests, and approvals is set forth in Paragraph 14.02.B.
- 9.09 *Limitations on Owner's Responsibilities*
- A. The Owner shall not supervise, direct, or have control or authority over, nor be responsible for, Contractor's means, methods, techniques, sequences, or procedures of construction, or the safety precautions and programs incident thereto, or for any failure of Contractor to comply with Laws and Regulations applicable to the performance of the Work. Owner will not be responsible for Contractor's failure to perform the Work in accordance with the Contract Documents.
- 9.10 *Undisclosed Hazardous Environmental Condition*
- A. Owner's responsibility in respect to an undisclosed Hazardous Environmental Condition is set forth in Paragraph 5.06.
- 9.11 *Evidence of Financial Arrangements*
- A. Upon request of Contractor, Owner shall furnish Contractor reasonable evidence that financial arrangements have been made to satisfy Owner's obligations under the Contract (including obligations under proposed changes in the Work).
- 9.12 *Safety Programs*
- A. While at the Site, Owner's employees and representatives shall comply with the specific applicable requirements of Contractor's safety programs of which Owner has been informed.
 - B. Owner shall furnish copies of any applicable Owner safety programs to Contractor.

See SC-9.12

ARTICLE 10—ENGINEER'S STATUS DURING CONSTRUCTION

10.01 *Owner's Representative*

- A. Engineer will be Owner's representative during the construction period. The duties and responsibilities and the limitations of authority of Engineer as Owner's representative during construction are set forth in the Contract.

10.02 *Visits to Site*

- A. Engineer will make visits to the Site at intervals appropriate to the various stages of construction as Engineer deems necessary in order to observe, as an experienced and qualified design professional, the progress that has been made and the quality of the various aspects of Contractor's executed Work. Based on information obtained during such visits and observations, Engineer, for the benefit of Owner, will determine, in general, if the Work is proceeding in accordance with the Contract Documents. Engineer will not be required to make exhaustive or continuous inspections on the Site to check the quality or quantity of the Work. Engineer's efforts will be directed toward providing for Owner a greater degree of confidence that the completed Work will conform generally to the Contract Documents. On the basis of such visits and observations, Engineer will keep Owner informed of the progress of the Work and will endeavor to guard Owner against defective Work.
- B. Engineer's visits and observations are subject to all the limitations on Engineer's authority and responsibility set forth in Paragraph 10.07. Particularly, but without limitation, during or as a result of Engineer's visits or observations of Contractor's Work, Engineer will not supervise, direct, control, or have authority over or be responsible for Contractor's means, methods, techniques, sequences, or procedures of construction, or the safety precautions and programs incident thereto, or for any failure of Contractor to comply with Laws and Regulations applicable to the performance of the Work.

10.03 *Resident Project Representative*

- A. If Owner and Engineer have agreed that Engineer will furnish a Resident Project Representative to represent Engineer at the Site and assist Engineer in observing the progress and quality of the Work, then the authority and responsibilities of any such Resident Project Representative will be as provided in the Supplementary Conditions, and limitations on the responsibilities thereof will be as provided in the Supplementary Conditions and in Paragraph 10.07.
- B. If Owner designates an individual or entity who is not Engineer's consultant, agent, or employee to represent Owner at the Site, then the responsibilities and authority of such individual or entity will be as provided in the Supplementary Conditions.

10.04 *Engineer's Authority*

- A. Engineer has the authority to reject Work in accordance with Article 14.
- B. Engineer's authority as to Submittals is set forth in Paragraph 7.16.
- C. Engineer's authority as to design drawings, calculations, specifications, certifications and other Submittals from Contractor in response to Owner's delegation (if any) to Contractor of professional design services, is set forth in Paragraph 7.19.
- D. Engineer's authority as to changes in the Work is set forth in Article 11.

E. Engineer's authority as to Applications for Payment is set forth in Article 15.

10.05 *Determinations for Unit Price Work*

A. ~~Engineer will determine the actual quantities and classifications of Unit Price Work performed by Contractor as set forth in Paragraph 13.03.~~

See SC-10.05

10.06 *Decisions on Requirements of Contract Documents and Acceptability of Work*

A. Engineer will render decisions regarding the requirements of the Contract Documents, and judge the acceptability of the Work, pursuant to the specific procedures set forth herein for initial interpretations, Change Proposals, and acceptance of the Work. In rendering such decisions and judgments, Engineer will not show partiality to Owner or Contractor, and will not be liable to Owner, Contractor, or others in connection with any proceedings, interpretations, decisions, or judgments conducted or rendered in good faith.

10.07 *Limitations on Engineer's Authority and Responsibilities*

- A. Neither Engineer's authority or responsibility under this Article 10 or under any other provision of the Contract, nor any decision made by Engineer in good faith either to exercise or not exercise such authority or responsibility or the undertaking, exercise, or performance of any authority or responsibility by Engineer, will create, impose, or give rise to any duty in contract, tort, or otherwise owed by Engineer to Contractor, any Subcontractor, any Supplier, any other individual or entity, or to any surety for or employee or agent of any of them.
- B. Engineer will not supervise, direct, control, or have authority over or be responsible for Contractor's means, methods, techniques, sequences, or procedures of construction, or the safety precautions and programs incident thereto, or for any failure of Contractor to comply with Laws and Regulations applicable to the performance of the Work. Engineer will not be responsible for Contractor's failure to perform the Work in accordance with the Contract Documents.
- C. Engineer will not be responsible for the acts or omissions of Contractor or of any Subcontractor, any Supplier, or of any other individual or entity performing any of the Work.
- D. Engineer's review of the final Application for Payment and accompanying documentation, and all maintenance and operating instructions, schedules, guarantees, bonds, certificates of inspection, tests and approvals, and other documentation required to be delivered by Contractor under Paragraph 15.06.A, will only be to determine generally that their content complies with the requirements of, and in the case of certificates of inspections, tests, and approvals, that the results certified indicate compliance with the Contract Documents.
- E. The limitations upon authority and responsibility set forth in this Paragraph 10.07 also apply to the Resident Project Representative, if any.

See SC-10.07

10.08 *Compliance with Safety Program*

A. While at the Site, Engineer's employees and representatives will comply with the specific applicable requirements of Owner's and Contractor's safety programs of which Engineer has been informed.

ARTICLE 11—CHANGES TO THE CONTRACT

11.01 *Amending and Supplementing the Contract*

- A. The Contract may be amended or supplemented by a Change Order, a Work Change Directive, or a Field Order.
- B. If an amendment or supplement to the Contract includes a change in the Contract Price or the Contract Times, such amendment or supplement must be set forth in a Change Order.
- C. All changes to the Contract that involve (1) the performance or acceptability of the Work, (2) the design (as set forth in the Drawings, Specifications, or otherwise), or (3) other engineering or technical matters, must be supported by Engineer's recommendation. Owner and Contractor may amend other terms and conditions of the Contract without the recommendation of the Engineer.

11.02 *Change Orders*

- A. Owner and Contractor shall execute appropriate Change Orders covering:
 - 1. Changes in Contract Price or Contract Times which are agreed to by the parties, including any undisputed sum or amount of time for Work actually performed in accordance with a Work Change Directive;
 - 2. Changes in Contract Price resulting from an Owner set-off, unless Contractor has duly contested such set-off;
 - 3. Changes in the Work which are: (a) ordered by Owner pursuant to Paragraph 11.05, (b) required because of Owner's acceptance of defective Work under Paragraph 14.04 or Owner's correction of defective Work under Paragraph 14.07, or (c) agreed to by the parties, subject to the need for Engineer's recommendation if the change in the Work involves the design (as set forth in the Drawings, Specifications, or otherwise) or other engineering or technical matters; and
 - 4. Changes that embody the substance of any final and binding results under: Paragraph 11.03.B, resolving the impact of a Work Change Directive; Paragraph 11.09, concerning Change Proposals; Article 12, Claims; Paragraph 13.02.D, final adjustments resulting from allowances; Paragraph 13.03.D, final adjustments relating to determination of quantities for Unit Price Work; and similar provisions.
- B. If Owner or Contractor refuses to execute a Change Order that is required to be executed under the terms of Paragraph 11.02.A, it will be deemed to be of full force and effect, as if fully executed.

11.03 *Work Change Directives*

- A. A Work Change Directive will not change the Contract Price or the Contract Times but is evidence that the parties expect that the modification ordered or documented by a Work Change Directive will be incorporated in a subsequently issued Change Order, following negotiations by the parties as to the Work Change Directive's effect, if any, on the Contract Price and Contract Times; or, if negotiations are unsuccessful, by a determination under the terms of the Contract Documents governing adjustments, expressly including Paragraph 11.07 regarding change of Contract Price.

See SC-11.03.B

- B. If Owner has issued a Work Change Directive and:
 - 1. ~~Contractor believes that an adjustment in Contract Times or Contract Price is necessary, then Contractor shall submit any Change Proposal seeking such an adjustment no later than 30 days after the completion of the Work set out in the Work Change Directive.~~
 - 2. ~~Owner believes that an adjustment in Contract Times or Contract Price is necessary, then Owner shall submit any Claim seeking such an adjustment no later than 60 days after issuance of the Work Change Directive.~~

11.04 *Field Orders*

- A. Engineer may authorize minor changes in the Work if the changes do not involve an adjustment in the Contract Price or the Contract Times and are compatible with the design concept of the completed Project as a functioning whole as indicated by the Contract Documents. Such changes will be accomplished by a Field Order and will be binding on Owner and also on Contractor, which shall perform the Work involved promptly.
- B. If Contractor believes that a Field Order justifies an adjustment in the Contract Price or Contract Times, then before proceeding with the Work at issue, Contractor shall submit a Change Proposal as provided herein.

11.05 *Owner-Authorized Changes in the Work*

- A. Without invalidating the Contract and without notice to any surety, Owner may, at any time or from time to time, order additions, deletions, or revisions in the Work. Changes involving the design (as set forth in the Drawings, Specifications, or otherwise) or other engineering or technical matters will be supported by Engineer's recommendation.
- B. Such changes in the Work may be accomplished by a Change Order, if Owner and Contractor have agreed as to the effect, if any, of the changes on Contract Times or Contract Price; or by a Work Change Directive. Upon receipt of any such document, Contractor shall promptly proceed with the Work involved; or, in the case of a deletion in the Work, promptly cease construction activities with respect to such deleted Work. Added or revised Work must be performed under the applicable conditions of the Contract Documents.
- C. Nothing in this Paragraph 11.05 obligates Contractor to undertake work that Contractor reasonably concludes cannot be performed in a manner consistent with Contractor's safety obligations under the Contract Documents or Laws and Regulations.

11.06 *Unauthorized Changes in the Work*

- A. Contractor shall not be entitled to an increase in the Contract Price or an extension of the Contract Times with respect to any work performed that is not required by the Contract Documents, as amended, modified, or supplemented, except in the case of an emergency as provided in Paragraph 7.15 or in the case of uncovering Work as provided in Paragraph 14.05.C.2.

11.07 *Change of Contract Price*

- A. The Contract Price may only be changed by a Change Order. Any Change Proposal for an adjustment in the Contract Price must comply with the provisions of Paragraph 11.09. Any Claim for an adjustment of Contract Price must comply with the provisions of Article 12.
- B. An adjustment in the Contract Price will be determined as follows:

1. Where the Work involved is covered by unit prices contained in the Contract Documents, then by application of such unit prices to the quantities of the items involved (subject to the provisions of Paragraph 13.03);
 2. Where the Work involved is not covered by unit prices contained in the Contract Documents, then by a mutually agreed lump sum (which may include an allowance for overhead and profit not necessarily in accordance with Paragraph 11.07.C.2); or
 3. Where the Work involved is not covered by unit prices contained in the Contract Documents and the parties do not reach mutual agreement to a lump sum, then on the basis of the Cost of the Work (determined as provided in Paragraph 13.01) plus a Contractor's fee for overhead and profit (determined as provided in Paragraph 11.07.C).
- C. *Contractor's Fee*: When applicable, the Contractor's fee for overhead and profit will be determined as follows:
1. A mutually acceptable fixed fee; or
 2. If a fixed fee is not agreed upon, then a fee based on the following percentages of the various portions of the Cost of the Work:
 - a. For costs incurred under Paragraphs 13.01.B.1 and 13.01.B.2, the Contractor's fee will be 15 percent;
 - b. For costs incurred under Paragraph 13.01.B.3, the Contractor's fee will be 5 percent;
 - c. Where one or more tiers of subcontracts are on the basis of Cost of the Work plus a fee and no fixed fee is agreed upon, the intent of Paragraphs 11.07.C.2.a and 11.07.C.2.b is that the Contractor's fee will be based on: (1) a fee of 15 percent of the costs incurred under Paragraphs 13.01.B.1 and 13.01.B.2 by the Subcontractor that actually performs the Work, at whatever tier, and (2) with respect to Contractor itself and to any Subcontractors of a tier higher than that of the Subcontractor that actually performs the Work, a fee of 5 percent of the amount (fee plus underlying costs incurred) attributable to the next lower tier Subcontractor; provided, however, that for any such subcontracted Work the maximum total fee to be paid by Owner will be no greater than 27 percent of the costs incurred by the Subcontractor that actually performs the Work;
 - d. No fee will be payable on the basis of costs itemized under Paragraphs 13.01.B.4, 13.01.B.5, and 13.01.C;
 - e. The amount of credit to be allowed by Contractor to Owner for any change which results in a net decrease in Cost of the Work will be the amount of the actual net decrease in Cost of the Work and a deduction of an additional amount equal to 5 percent of such actual net decrease in Cost of the Work; and
 - f. When both additions and credits are involved in any one change or Change Proposal, the adjustment in Contractor's fee will be computed by determining the sum of the costs in each of the cost categories in Paragraph 13.01.B (specifically, payroll costs, Paragraph 13.01.B.1; incorporated materials and equipment costs, Paragraph 13.01.B.2; Subcontract costs, Paragraph 13.01.B.3; special consultants costs, Paragraph 13.01.B.4; and other costs, Paragraph 13.01.B.5) and applying to each such cost category sum the appropriate fee from Paragraphs 11.07.C.2.a through 11.07.C.2.e, inclusive.

See SC-11.07.D & E

11.08 *Change of Contract Times*

- A. The Contract Times may only be changed by a Change Order. Any Change Proposal for an adjustment in the Contract Times must comply with the provisions of Paragraph 11.09. Any Claim for an adjustment in the Contract Times must comply with the provisions of Article 12.
- B. Delay, disruption, and interference in the Work, and any related changes in Contract Times, are addressed in and governed by Paragraph 4.05.

See SC-11.08.C

11.09 *Change Proposals*

- A. *Purpose and Content:* Contractor shall submit a Change Proposal to Engineer to request an adjustment in the Contract Times or Contract Price; contest an initial decision by Engineer concerning the requirements of the Contract Documents or relating to the acceptability of the Work under the Contract Documents; challenge a set-off against payment due; or seek other relief under the Contract. The Change Proposal will specify any proposed change in Contract Times or Contract Price, or other proposed relief, and explain the reason for the proposed change, with citations to any governing or applicable provisions of the Contract Documents. Each Change Proposal will address only one issue, or a set of closely related issues.
- B. *Change Proposal Procedures*
 - 1. *Submittal:* Contractor shall submit each Change Proposal to Engineer within 30 days after the start of the event giving rise thereto, or after such initial decision.
 - 2. *Supporting Data:* The Contractor shall submit supporting data, including the proposed change in Contract Price or Contract Time (if any), to the Engineer and Owner within 15 days after the submittal of the Change Proposal.
 - a. Change Proposals based on or related to delay, interruption, or interference must comply with the provisions of Paragraphs 4.05.D and 4.05.E.
 - b. Change proposals related to a change of Contract Price must include full and detailed accounts of materials incorporated into the Work and labor and equipment used for the subject Work.

The supporting data must be accompanied by a written statement that the supporting data are accurate and complete, and that any requested time or price adjustment is the entire adjustment to which Contractor believes it is entitled as a result of said event.

- 3. *Engineer's Initial Review:* Engineer will advise Owner regarding the Change Proposal, and consider any comments or response from Owner regarding the Change Proposal. If in its discretion Engineer concludes that additional supporting data is needed before conducting a full review and making a decision regarding the Change Proposal, then Engineer may request that Contractor submit such additional supporting data by a date specified by Engineer, prior to Engineer beginning its full review of the Change Proposal.
- 4. *Engineer's Full Review and Action on the Change Proposal:* Upon receipt of Contractor's supporting data (including any additional data requested by Engineer), Engineer will conduct a full review of each Change Proposal and, within 30 days after such receipt of

the Contractor's supporting data, either approve the Change Proposal in whole, deny it in whole, or approve it in part and deny it in part. Such actions must be in writing, with a copy provided to Owner and Contractor. If Engineer does not take action on the Change Proposal within 30 days, then either Owner or Contractor may at any time thereafter submit a letter to the other party indicating that as a result of Engineer's inaction the Change Proposal is deemed denied, thereby commencing the time for appeal of the denial under Article 12.

5. *Binding Decision*: Engineer's decision is final and binding upon Owner and Contractor, unless Owner or Contractor appeals the decision by filing a Claim under Article 12.
- C. *Resolution of Certain Change Proposals*: If the Change Proposal does not involve the design (as set forth in the Drawings, Specifications, or otherwise), the acceptability of the Work, or other engineering or technical matters, then Engineer will notify the parties in writing that the Engineer is unable to resolve the Change Proposal. For purposes of further resolution of such a Change Proposal, such notice will be deemed a denial, and Contractor may choose to seek resolution under the terms of Article 12.
- D. *Post-Completion*: Contractor shall not submit any Change Proposals after Engineer issues a written recommendation of final payment pursuant to Paragraph 15.06.B.

11.10 *Notification to Surety*

- A. If the provisions of any bond require notice to be given to a surety of any change affecting the general scope of the Work or the provisions of the Contract Documents (including, but not limited to, Contract Price or Contract Times), the giving of any such notice will be Contractor's responsibility. The amount of each applicable bond will be adjusted to reflect the effect of any such change.

ARTICLE 12—CLAIMS

12.01 *Claims*

- A. *Claims Process*: The following disputes between Owner and Contractor are subject to the Claims process set forth in this article:
 1. Appeals by Owner or Contractor of Engineer's decisions regarding Change Proposals;
 2. Owner demands for adjustments in the Contract Price or Contract Times, or other relief under the Contract Documents;
 3. Disputes that Engineer has been unable to address because they do not involve the design (as set forth in the Drawings, Specifications, or otherwise), the acceptability of the Work, or other engineering or technical matters; and
 4. Subject to the waiver provisions of Paragraph 15.07, any dispute arising after Engineer has issued a written recommendation of final payment pursuant to Paragraph 15.06.B.
- B. *Submittal of Claim*: The party submitting a Claim shall deliver it directly to the other party to the Contract promptly (but in no event later than 30 days after the start of the event giving rise thereto; in the case of appeals regarding Change Proposals within 30 days of the decision under appeal. The party submitting the Claim shall also furnish a copy to the Engineer, for its information only. The responsibility to substantiate a Claim rests with the party making the Claim. In the case of a Claim by Contractor seeking an increase in the Contract Times or

Contract Price, Contractor shall certify that the Claim is made in good faith, that the supporting data are accurate and complete, and that to the best of Contractor's knowledge and belief the amount of time or money requested accurately reflects the full amount to which Contractor is entitled.

- C. *Review and Resolution:* The party receiving a Claim shall review it thoroughly, giving full consideration to its merits. The two parties shall seek to resolve the Claim through the exchange of information and direct negotiations. The parties may extend the time for resolving the Claim by mutual agreement. All actions taken on a Claim will be stated in writing and submitted to the other party, with a copy to Engineer.
- D. *Mediation*
 - 1. At any time after initiation of a Claim, Owner and Contractor may mutually agree to mediation of the underlying dispute. The agreement to mediate will stay the Claim submittal and response process.
 - 2. If Owner and Contractor agree to mediation, then after 60 days from such agreement, either Owner or Contractor may unilaterally terminate the mediation process, and the Claim submittal and decision process will resume as of the date of the termination. If the mediation proceeds but is unsuccessful in resolving the dispute, the Claim submittal and decision process will resume as of the date of the conclusion of the mediation, as determined by the mediator.
 - 3. Owner and Contractor shall each pay one-half of the mediator's fees and costs.
- E. *Partial Approval:* If the party receiving a Claim approves the Claim in part and denies it in part, such action will be final and binding unless within 30 days of such action the other party invokes the procedure set forth in Article 17 for final resolution of disputes.
- F. *Denial of Claim:* If efforts to resolve a Claim are not successful, the party receiving the Claim may deny it by giving written notice of denial to the other party. If the receiving party does not take action on the Claim within 90 days, then either Owner or Contractor may at any time thereafter submit a letter to the other party indicating that as a result of the inaction, the Claim is deemed denied, thereby commencing the time for appeal of the denial. A denial of the Claim will be final and binding unless within 30 days of the denial the other party invokes the procedure set forth in Article 17 for the final resolution of disputes.
- G. *Final and Binding Results:* If the parties reach a mutual agreement regarding a Claim, whether through approval of the Claim, direct negotiations, mediation, or otherwise; or if a Claim is approved in part and denied in part, or denied in full, and such actions become final and binding; then the results of the agreement or action on the Claim will be incorporated in a Change Order or other written document to the extent they affect the Contract, including the Work, the Contract Times, or the Contract Price.

ARTICLE 13—COST OF THE WORK; ALLOWANCES; UNIT PRICE WORK

13.01 *Cost of the Work*

- A. *Purposes for Determination of Cost of the Work:* The term Cost of the Work means the sum of all costs necessary for the proper performance of the Work at issue, as further defined below. The provisions of this Paragraph 13.01 are used for two distinct purposes:
1. To determine Cost of the Work when Cost of the Work is a component of the Contract Price, under cost-plus-fee, time-and-materials, or other cost-based terms; or
 2. When needed to determine the value of a Change Order, Change Proposal, Claim, set-off, or other adjustment in Contract Price. When the value of any such adjustment is determined on the basis of Cost of the Work, Contractor is entitled only to those additional or incremental costs required because of the change in the Work or because of the event giving rise to the adjustment.
- B. *Costs Included:* Except as otherwise may be agreed to in writing by Owner, costs included in the Cost of the Work will be in amounts no higher than those commonly incurred in the locality of the Project, will not include any of the costs itemized in Paragraph 13.01.C, and will include only the following items:
1. Payroll costs for employees in the direct employ of Contractor in the performance of the Work under schedules of job classifications agreed upon by Owner and Contractor in advance of the subject Work. Such employees include, without limitation, superintendents, foremen, safety managers, safety representatives, and other personnel employed full time on the Work. Payroll costs for employees not employed full time on the Work will be apportioned on the basis of their time spent on the Work. Payroll costs include, but are not limited to, salaries and wages plus the cost of fringe benefits, which include social security contributions, unemployment, excise, and payroll taxes, workers' compensation, health and retirement benefits, sick leave, and vacation and holiday pay applicable thereto. The expenses of performing Work outside of regular working hours, on Saturday, Sunday, or legal holidays, will be included in the above to the extent authorized by Owner.
 2. Cost of all materials and equipment furnished and incorporated in the Work, including costs of transportation and storage thereof, and Suppliers' field services required in connection therewith. All cash discounts accrue to Contractor unless Owner deposits funds with Contractor with which to make payments, in which case the cash discounts will accrue to Owner. All trade discounts, rebates, and refunds and returns from sale of surplus materials and equipment will accrue to Owner, and Contractor shall make provisions so that they may be obtained.
 3. Payments made by Contractor to Subcontractors for Work performed by Subcontractors. If required by Owner, Contractor shall obtain competitive bids from subcontractors acceptable to Owner and Contractor and shall deliver such bids to Owner, which will then determine, with the advice of Engineer, which bids, if any, will be acceptable. If any subcontract provides that the Subcontractor is to be paid on the basis of Cost of the Work plus a fee, the Subcontractor's Cost of the Work and fee will be determined in the same manner as Contractor's Cost of the Work and fee as provided in this Paragraph 13.01.

4. Costs of special consultants (including but not limited to engineers, architects, testing laboratories, surveyors, attorneys, and accountants) employed or retained for services specifically related to the Work.
5. Other costs consisting of the following:
 - a. The proportion of necessary transportation, travel, and subsistence expenses of Contractor's employees incurred in discharge of duties connected with the Work.
 - b. Cost, including transportation and maintenance, of all materials, supplies, equipment, machinery, appliances, office, and temporary facilities at the Site, which are consumed in the performance of the Work, and cost, less market value, of such items used but not consumed which remain the property of Contractor.
 - 1) In establishing included costs for materials such as scaffolding, plating, or sheeting, consideration will be given to the actual or the estimated life of the material for use on other projects; or rental rates may be established on the basis of purchase or salvage value of such items, whichever is less. Contractor will not be eligible for compensation for such items in an amount that exceeds the purchase cost of such item.
 - c. *Construction Equipment Rental*
 - 1) Rentals of all construction equipment and machinery, and the parts thereof, in accordance with rental agreements approved by Owner as to price (including any surcharge or special rates applicable to overtime use of the construction equipment or machinery), and the costs of transportation, loading, unloading, assembly, dismantling, and removal thereof. All such costs will be in accordance with the terms of said rental agreements. The rental of any such equipment, machinery, or parts must cease when the use thereof is no longer necessary for the Work.
 - 2) Costs for equipment and machinery owned by Contractor or a Contractor-related entity will be paid at a rate shown for such equipment in the equipment rental rate book specified in the Supplementary Conditions. An hourly rate will be computed by dividing the monthly rates by 176. These computed rates will include all operating costs.
 - 3) With respect to Work that is the result of a Change Order, Change Proposal, Claim, set-off, or other adjustment in Contract Price ("changed Work"), included costs will be based on the time the equipment or machinery is in use on the changed Work and the costs of transportation, loading, unloading, assembly, dismantling, and removal when directly attributable to the changed Work. The cost of any such equipment or machinery, or parts thereof, must cease to accrue when the use thereof is no longer necessary for the changed Work.
 - d. Sales, consumer, use, and other similar taxes related to the Work, and for which Contractor is liable, as imposed by Laws and Regulations.
 - e. Deposits lost for causes other than negligence of Contractor, any Subcontractor, or anyone directly or indirectly employed by any of them or for whose acts any of them may be liable, and royalty payments and fees for permits and licenses.

- f. Losses and damages (and related expenses) caused by damage to the Work, not compensated by insurance or otherwise, sustained by Contractor in connection with the performance of the Work (except losses and damages within the deductible amounts of builder's risk or other property insurance established in accordance with Paragraph 6.04), provided such losses and damages have resulted from causes other than the negligence of Contractor, any Subcontractor, or anyone directly or indirectly employed by any of them or for whose acts any of them may be liable. Such losses include settlements made with the written consent and approval of Owner. No such losses, damages, and expenses will be included in the Cost of the Work for the purpose of determining Contractor's fee.
 - g. The cost of utilities, fuel, and sanitary facilities at the Site.
 - h. Minor expenses such as communication service at the Site, express and courier services, and similar petty cash items in connection with the Work.
 - i. The costs of premiums for all bonds and insurance that Contractor is required by the Contract Documents to purchase and maintain.
- C. *Costs Excluded*: The term Cost of the Work does not include any of the following items:
- 1. Payroll costs and other compensation of Contractor's officers, executives, principals, general managers, engineers, architects, estimators, attorneys, auditors, accountants, purchasing and contracting agents, expeditors, timekeepers, clerks, and other personnel employed by Contractor, whether at the Site or in Contractor's principal or branch office for general administration of the Work and not specifically included in the agreed upon schedule of job classifications referred to in Paragraph 13.01.B.1 or specifically covered by Paragraph 13.01.B.4. The payroll costs and other compensation excluded here are to be considered administrative costs covered by the Contractor's fee.
 - 2. The cost of purchasing, renting, or furnishing small tools and hand tools.
 - 3. Expenses of Contractor's principal and branch offices other than Contractor's office at the Site.
 - 4. Any part of Contractor's capital expenses, including interest on Contractor's capital employed for the Work and charges against Contractor for delinquent payments.
 - 5. Costs due to the negligence of Contractor, any Subcontractor, or anyone directly or indirectly employed by any of them or for whose acts any of them may be liable, including but not limited to, the correction of defective Work, disposal of materials or equipment wrongly supplied, and making good any damage to property.
 - 6. Expenses incurred in preparing and advancing Claims.
 - 7. Other overhead or general expense costs of any kind and the costs of any item not specifically and expressly included in Paragraph 13.01.B.
- D. *Contractor's Fee*
- 1. When the Work as a whole is performed on the basis of cost-plus-a-fee, then:
 - a. Contractor's fee for the Work set forth in the Contract Documents as of the Effective Date of the Contract will be determined as set forth in the Agreement.

- b. for any Work covered by a Change Order, Change Proposal, Claim, set-off, or other adjustment in Contract Price on the basis of Cost of the Work, Contractor's fee will be determined as follows:
 - 1) When the fee for the Work as a whole is a percentage of the Cost of the Work, the fee will automatically adjust as the Cost of the Work changes.
 - 2) When the fee for the Work as a whole is a fixed fee, the fee for any additions or deletions will be determined in accordance with Paragraph 11.07.C.2.
- 2. When the Work as a whole is performed on the basis of a stipulated sum, or any other basis other than cost-plus-a-fee, then Contractor's fee for any Work covered by a Change Order, Change Proposal, Claim, set-off, or other adjustment in Contract Price on the basis of Cost of the Work will be determined in accordance with Paragraph 11.07.C.2.
- E. *Documentation and Audit*: Whenever the Cost of the Work for any purpose is to be determined pursuant to this Article 13, Contractor and pertinent Subcontractors will establish and maintain records of the costs in accordance with generally accepted accounting practices. Subject to prior written notice, Owner will be afforded reasonable access, during normal business hours, to all Contractor's accounts, records, books, correspondence, instructions, drawings, receipts, vouchers, memoranda, and similar data relating to the Cost of the Work and Contractor's fee. Contractor shall preserve all such documents for a period of three years after the final payment by Owner. Pertinent Subcontractors will afford such access to Owner, and preserve such documents, to the same extent required of Contractor.

13.02 Allowances

- A. It is understood that Contractor has included in the Contract Price all allowances so named in the Contract Documents and shall cause the Work so covered to be performed for such sums and by such persons or entities as may be acceptable to Owner and Engineer.
- B. *Cash Allowances*: Contractor agrees that:
 - 1. the cash allowances include the cost to Contractor (less any applicable trade discounts) of materials and equipment required by the allowances to be delivered at the Site, and all applicable taxes; and
 - 2. Contractor's costs for unloading and handling on the Site, labor, installation, overhead, profit, and other expenses contemplated for the cash allowances have been included in the Contract Price and not in the allowances, and no demand for additional payment for any of the foregoing will be valid.
- C. *Owner's Contingency Allowance*: Contractor agrees that an Owner's contingency allowance, if any, is for the sole use of Owner to cover unanticipated costs.
- D. Prior to final payment, an appropriate Change Order will be issued as recommended by Engineer to reflect actual amounts due Contractor for Work covered by allowances, and the Contract Price will be correspondingly adjusted.

13.03 Unit Price Work

- A. Where the Contract Documents provide that all or part of the Work is to be Unit Price Work, initially the Contract Price will be deemed to include for all Unit Price Work an amount equal to the sum of the unit price for each separately identified item of Unit Price Work times the estimated quantity of each item as indicated in the Agreement.

- B. The estimated quantities of items of Unit Price Work are not guaranteed and are solely for the purpose of comparison of Bids and determining an initial Contract Price. Payments to Contractor for Unit Price Work will be based on actual quantities.
- C. Each unit price will be deemed to include an amount considered by Contractor to be adequate to cover Contractor's overhead and profit for each separately identified item.
- D. Engineer will determine the actual quantities and classifications of Unit Price Work performed by Contractor. Engineer will review with Contractor the Engineer's preliminary determinations on such matters before rendering a written decision thereon (by recommendation of an Application for Payment or otherwise). Engineer's written decision thereon will be final and binding (except as modified by Engineer to reflect changed factual conditions or more accurate data) upon Owner and Contractor, and the final adjustment of Contract Price will be set forth in a Change Order, subject to the provisions of the following paragraph.
- E. *Adjustments in Unit Price*
 - 1. Contractor or Owner shall be entitled to an adjustment in the unit price with respect to an item of Unit Price Work if:
 - a. the quantity of the item of Unit Price Work performed by Contractor differs materially and significantly from the estimated quantity of such item indicated in the Agreement; and
 - b. Contractor's unit costs to perform the item of Unit Price Work have changed materially and significantly as a result of the quantity change.
 - 2. The adjustment in unit price will account for and be coordinated with any related changes in quantities of other items of Work, and in Contractor's costs to perform such other Work, such that the resulting overall change in Contract Price is equitable to Owner and Contractor.
 - 3. Adjusted unit prices will apply to all units of that item.

ARTICLE 14—TESTS AND INSPECTIONS; CORRECTION, REMOVAL, OR ACCEPTANCE OF DEFECTIVE WORK

14.01 *Access to Work*

- A. Owner, Engineer, their consultants and other representatives and personnel of Owner, independent testing laboratories, and authorities having jurisdiction have access to the Site and the Work at reasonable times for their observation, inspection, and testing. Contractor shall provide them proper and safe conditions for such access and advise them of Contractor's safety procedures and programs so that they may comply with such procedures and programs as applicable.

14.02 *Tests, Inspections, and Approvals*

- A. Contractor shall give Engineer timely notice of readiness of the Work (or specific parts thereof) for all required inspections and tests, and shall cooperate with inspection and testing personnel to facilitate required inspections and tests.
- B. Owner shall retain and pay for the services of an independent inspector, testing laboratory, or other qualified individual or entity to perform all inspections and tests expressly required

by the Contract Documents to be furnished and paid for by Owner, except that costs incurred in connection with tests or inspections of covered Work will be governed by the provisions of Paragraph 14.05.

- C. If Laws or Regulations of any public body having jurisdiction require any Work (or part thereof) specifically to be inspected, tested, or approved by an employee or other representative of such public body, Contractor shall assume full responsibility for arranging and obtaining such inspections, tests, or approvals, pay all costs in connection therewith, and furnish Engineer the required certificates of inspection or approval.
- D. Contractor shall be responsible for arranging, obtaining, and paying for all inspections and tests required:
 - 1. by the Contract Documents, unless the Contract Documents expressly allocate responsibility for a specific inspection or test to Owner;
 - 2. to attain Owner's and Engineer's acceptance of materials or equipment to be incorporated in the Work;
 - 3. by manufacturers of equipment furnished under the Contract Documents;
 - 4. for testing, adjusting, and balancing of mechanical, electrical, and other equipment to be incorporated into the Work; and
 - 5. for acceptance of materials, mix designs, or equipment submitted for approval prior to Contractor's purchase thereof for incorporation in the Work.

Such inspections and tests will be performed by independent inspectors, testing laboratories, or other qualified individuals or entities acceptable to Owner and Engineer.

- E. If the Contract Documents require the Work (or part thereof) to be approved by Owner, Engineer, or another designated individual or entity, then Contractor shall assume full responsibility for arranging and obtaining such approvals.
- F. If any Work (or the work of others) that is to be inspected, tested, or approved is covered by Contractor without written concurrence of Engineer, Contractor shall, if requested by Engineer, uncover such Work for observation. Such uncovering will be at Contractor's expense unless Contractor had given Engineer timely notice of Contractor's intention to cover the same and Engineer had not acted with reasonable promptness in response to such notice.

14.03 *Defective Work*

- A. *Contractor's Obligation:* It is Contractor's obligation to assure that the Work is not defective.
- B. *Engineer's Authority:* Engineer has the authority to determine whether Work is defective, and to reject defective Work.
- C. *Notice of Defects:* Prompt written notice of all defective Work of which Owner or Engineer has actual knowledge will be given to Contractor.
- D. *Correction, or Removal and Replacement:* Promptly after receipt of written notice of defective Work, Contractor shall correct all such defective Work, whether or not fabricated, installed, or completed, or, if Engineer has rejected the defective Work, remove it from the Project and replace it with Work that is not defective.

- E. *Preservation of Warranties*: When correcting defective Work, Contractor shall take no action that would void or otherwise impair Owner's special warranty and guarantee, if any, on said Work.
- F. *Costs and Damages*: In addition to its correction, removal, and replacement obligations with respect to defective Work, Contractor shall pay all claims, costs, losses, and damages arising out of or relating to defective Work, including but not limited to the cost of the inspection, testing, correction, removal, replacement, or reconstruction of such defective Work, fines levied against Owner by governmental authorities because the Work is defective, and the costs of repair or replacement of work of others resulting from defective Work. Prior to final payment, if Owner and Contractor are unable to agree as to the measure of such claims, costs, losses, and damages resulting from defective Work, then Owner may impose a reasonable set-off against payments due under Article 15.

14.04 *Acceptance of Defective Work*

- A. If, instead of requiring correction or removal and replacement of defective Work, Owner prefers to accept it, Owner may do so (subject, if such acceptance occurs prior to final payment, to Engineer's confirmation that such acceptance is in general accord with the design intent and applicable engineering principles, and will not endanger public safety). Contractor shall pay all claims, costs, losses, and damages attributable to Owner's evaluation of and determination to accept such defective Work (such costs to be approved by Engineer as to reasonableness), and for the diminished value of the Work to the extent not otherwise paid by Contractor. If any such acceptance occurs prior to final payment, the necessary revisions in the Contract Documents with respect to the Work will be incorporated in a Change Order. If the parties are unable to agree as to the decrease in the Contract Price, reflecting the diminished value of Work so accepted, then Owner may impose a reasonable set-off against payments due under Article 15. If the acceptance of defective Work occurs after final payment, Contractor shall pay an appropriate amount to Owner.

14.05 *Uncovering Work*

- A. Engineer has the authority to require additional inspection or testing of the Work, whether or not the Work is fabricated, installed, or completed.
- B. If any Work is covered contrary to the written request of Engineer, then Contractor shall, if requested by Engineer, uncover such Work for Engineer's observation, and then replace the covering, all at Contractor's expense.
- C. If Engineer considers it necessary or advisable that covered Work be observed by Engineer or inspected or tested by others, then Contractor, at Engineer's request, shall uncover, expose, or otherwise make available for observation, inspection, or testing as Engineer may require, that portion of the Work in question, and provide all necessary labor, material, and equipment.
 - 1. If it is found that the uncovered Work is defective, Contractor shall be responsible for all claims, costs, losses, and damages arising out of or relating to such uncovering, exposure, observation, inspection, and testing, and of satisfactory replacement or reconstruction (including but not limited to all costs of repair or replacement of work of others); and pending Contractor's full discharge of this responsibility the Owner shall be entitled to impose a reasonable set-off against payments due under Article 15.

2. If the uncovered Work is not found to be defective, Contractor shall be allowed an increase in the Contract Price or an extension of the Contract Times, directly attributable to such uncovering, exposure, observation, inspection, testing, replacement, and reconstruction. If the parties are unable to agree as to the amount or extent thereof, then Contractor may submit a Change Proposal within 30 days of the determination that the Work is not defective.

14.06 *Owner May Stop the Work*

- A. If the Work is defective, or Contractor fails to supply sufficient skilled workers or suitable materials or equipment, or fails to perform the Work in such a way that the completed Work will conform to the Contract Documents, then Owner may order Contractor to stop the Work, or any portion thereof, until the cause for such order has been eliminated; however, this right of Owner to stop the Work will not give rise to any duty on the part of Owner to exercise this right for the benefit of Contractor, any Subcontractor, any Supplier, any other individual or entity, or any surety for, or employee or agent of any of them.

14.07 *Owner May Correct Defective Work*

- A. If Contractor fails within a reasonable time after written notice from Engineer to correct defective Work, or to remove and replace defective Work as required by Engineer, then Owner may, after 7 days' written notice to Contractor, correct or remedy any such deficiency.
- B. In exercising the rights and remedies under this Paragraph 14.07, Owner shall proceed expeditiously. In connection with such corrective or remedial action, Owner may exclude Contractor from all or part of the Site, take possession of all or part of the Work and suspend Contractor's services related thereto, and incorporate in the Work all materials and equipment stored at the Site or for which Owner has paid Contractor but which are stored elsewhere. Contractor shall allow Owner, Owner's representatives, agents and employees, Owner's other contractors, and Engineer and Engineer's consultants access to the Site to enable Owner to exercise the rights and remedies under this paragraph.
- C. All claims, costs, losses, and damages incurred or sustained by Owner in exercising the rights and remedies under this Paragraph 14.07 will be charged against Contractor as set-offs against payments due under Article 15. Such claims, costs, losses and damages will include but not be limited to all costs of repair, or replacement of work of others destroyed or damaged by correction, removal, or replacement of Contractor's defective Work.
- D. Contractor shall not be allowed an extension of the Contract Times because of any delay in the performance of the Work attributable to the exercise by Owner of Owner's rights and remedies under this Paragraph 14.07.

ARTICLE 15—PAYMENTS TO CONTRACTOR; SET-OFFS; COMPLETION; CORRECTION PERIOD

15.01 *Progress Payments*

- A. *Basis for Progress Payments:* The Schedule of Values established as provided in Article 2 will serve as the basis for progress payments and will be incorporated into a form of Application for Payment acceptable to Engineer. Progress payments for Unit Price Work will be based on the number of units completed during the pay period, as determined under the provisions of Paragraph 13.03. Progress payments for cost-based Work will be based on Cost of the Work completed by Contractor during the pay period.

B. Applications for Payments

1. At least 20 days before the date established in the Agreement for each progress payment (but not more often than once a month), Contractor shall submit to Engineer for review an Application for Payment filled out and signed by Contractor covering the Work completed as of the date of the Application and accompanied by such supporting documentation as is required by the Contract Documents.
2. If payment is requested on the basis of materials and equipment not incorporated in the Work but delivered and suitably stored at the Site or at another location agreed to in writing, the Application for Payment must also be accompanied by: (a) a bill of sale, invoice, copies of subcontract or purchase order payments, or other documentation establishing full payment by Contractor for the materials and equipment; (b) at Owner's request, documentation warranting that Owner has received the materials and equipment free and clear of all Liens; and (c) evidence that the materials and equipment are covered by appropriate property insurance, a warehouse bond, or other arrangements to protect Owner's interest therein, all of which must be satisfactory to Owner.
3. Beginning with the second Application for Payment, each Application must include an affidavit of Contractor stating that all previous progress payments received by Contractor have been applied to discharge Contractor's legitimate obligations associated with prior Applications for Payment.
4. The amount of retainage with respect to progress payments will be as stipulated in the Agreement.

C. Review of Applications

1. Engineer will, within 10 days after receipt of each Application for Payment, including each resubmittal, either indicate in writing a recommendation of payment and present the Application to Owner, or return the Application to Contractor indicating in writing Engineer's reasons for refusing to recommend payment. In the latter case, Contractor may make the necessary corrections and resubmit the Application.
2. Engineer's recommendation of any payment requested in an Application for Payment will constitute a representation by Engineer to Owner, based on Engineer's observations of the executed Work as an experienced and qualified design professional, and on Engineer's review of the Application for Payment and the accompanying data and schedules, that to the best of Engineer's knowledge, information and belief:
 - a. the Work has progressed to the point indicated;
 - b. the quality of the Work is generally in accordance with the Contract Documents (subject to an evaluation of the Work as a functioning whole prior to or upon Substantial Completion, the results of any subsequent tests called for in the Contract Documents, a final determination of quantities and classifications for Unit Price Work under Paragraph 13.03, and any other qualifications stated in the recommendation); and
 - c. the conditions precedent to Contractor's being entitled to such payment appear to have been fulfilled in so far as it is Engineer's responsibility to observe the Work.

3. By recommending any such payment Engineer will not thereby be deemed to have represented that:
 - a. inspections made to check the quality or the quantity of the Work as it has been performed have been exhaustive, extended to every aspect of the Work in progress, or involved detailed inspections of the Work beyond the responsibilities specifically assigned to Engineer in the Contract; or
 - b. there may not be other matters or issues between the parties that might entitle Contractor to be paid additionally by Owner or entitle Owner to withhold payment to Contractor.
4. Neither Engineer's review of Contractor's Work for the purposes of recommending payments nor Engineer's recommendation of any payment, including final payment, will impose responsibility on Engineer:
 - a. to supervise, direct, or control the Work;
 - b. for the means, methods, techniques, sequences, or procedures of construction, or the safety precautions and programs incident thereto;
 - c. for Contractor's failure to comply with Laws and Regulations applicable to Contractor's performance of the Work;
 - d. to make any examination to ascertain how or for what purposes Contractor has used the money paid by Owner; or
 - e. to determine that title to any of the Work, materials, or equipment has passed to Owner free and clear of any Liens.
5. Engineer may refuse to recommend the whole or any part of any payment if, in Engineer's opinion, it would be incorrect to make the representations to Owner stated in Paragraph 15.01.C.2.
6. Engineer will recommend reductions in payment (set-offs) necessary in Engineer's opinion to protect Owner from loss because:
 - a. the Work is defective, requiring correction or replacement;
 - b. the Contract Price has been reduced by Change Orders;
 - c. Owner has been required to correct defective Work in accordance with Paragraph 14.07, or has accepted defective Work pursuant to Paragraph 14.04;
 - d. Owner has been required to remove or remediate a Hazardous Environmental Condition for which Contractor is responsible; or
 - e. Engineer has actual knowledge of the occurrence of any of the events that would constitute a default by Contractor and therefore justify termination for cause under the Contract Documents.

D. Payment Becomes Due

1. Ten days after presentation of the Application for Payment to Owner with Engineer's recommendation, the amount recommended (subject to any Owner set-offs) will become due, and when due will be paid by Owner to Contractor.

E. *Reductions in Payment by Owner*

1. In addition to any reductions in payment (set-offs) recommended by Engineer, Owner is entitled to impose a set-off against payment based on any of the following:
 - a. Claims have been made against Owner based on Contractor's conduct in the performance or furnishing of the Work, or Owner has incurred costs, losses, or damages resulting from Contractor's conduct in the performance or furnishing of the Work, including but not limited to claims, costs, losses, or damages from workplace injuries, adjacent property damage, non-compliance with Laws and Regulations, and patent infringement;
 - b. Contractor has failed to take reasonable and customary measures to avoid damage, delay, disruption, and interference with other work at or adjacent to the Site;
 - c. Contractor has failed to provide and maintain required bonds or insurance;
 - d. Owner has been required to remove or remediate a Hazardous Environmental Condition for which Contractor is responsible;
 - e. Owner has incurred extra charges or engineering costs related to submittal reviews, evaluations of proposed substitutes, tests and inspections, or return visits to manufacturing or assembly facilities;
 - f. The Work is defective, requiring correction or replacement;
 - g. Owner has been required to correct defective Work in accordance with Paragraph 14.07, or has accepted defective Work pursuant to Paragraph 14.04;
 - h. The Contract Price has been reduced by Change Orders;
 - i. An event has occurred that would constitute a default by Contractor and therefore justify a termination for cause;
 - j. Liquidated or other damages have accrued as a result of Contractor's failure to achieve Milestones, Substantial Completion, or final completion of the Work;
 - k. Liens have been filed in connection with the Work, except where Contractor has delivered a specific bond satisfactory to Owner to secure the satisfaction and discharge of such Liens; or
 - l. Other items entitle Owner to a set-off against the amount recommended.
2. If Owner imposes any set-off against payment, whether based on its own knowledge or on the written recommendations of Engineer, Owner will give Contractor immediate written notice (with a copy to Engineer) stating the reasons for such action and the specific amount of the reduction, and promptly pay Contractor any amount remaining after deduction of the amount so withheld. Owner shall promptly pay Contractor the amount so withheld, or any adjustment thereto agreed to by Owner and Contractor, if Contractor remedies the reasons for such action. The reduction imposed will be binding on Contractor unless it duly submits a Change Proposal contesting the reduction.
3. Upon a subsequent determination that Owner's refusal of payment was not justified, the amount wrongfully withheld will be treated as an amount due as determined by Paragraph 15.01.D.1 and subject to interest as provided in the Agreement.

15.02 *Contractor's Warranty of Title*

- A. Contractor warrants and guarantees that title to all Work, materials, and equipment furnished under the Contract will pass to Owner free and clear of (1) all Liens and other title defects, and (2) all patent, licensing, copyright, or royalty obligations, no later than 7 days after the time of payment by Owner.

15.03 *Substantial Completion*

- A. When Contractor considers the entire Work ready for its intended use Contractor shall notify Owner and Engineer in writing that the entire Work is substantially complete and request that Engineer issue a certificate of Substantial Completion. Contractor shall at the same time submit to Owner and Engineer an initial draft of punch list items to be completed or corrected before final payment.
- B. Promptly after Contractor's notification, Owner, Contractor, and Engineer shall make an inspection of the Work to determine the status of completion. If Engineer does not consider the Work substantially complete, Engineer will notify Contractor in writing giving the reasons therefor.
- C. If Engineer considers the Work substantially complete, Engineer will deliver to Owner a preliminary certificate of Substantial Completion which will fix the date of Substantial Completion. Engineer shall attach to the certificate a punch list of items to be completed or corrected before final payment. Owner shall have 7 days after receipt of the preliminary certificate during which to make written objection to Engineer as to any provisions of the certificate or attached punch list. If, after considering the objections to the provisions of the preliminary certificate, Engineer concludes that the Work is not substantially complete, Engineer will, within 14 days after submission of the preliminary certificate to Owner, notify Contractor in writing that the Work is not substantially complete, stating the reasons therefor. If Owner does not object to the provisions of the certificate, or if despite consideration of Owner's objections Engineer concludes that the Work is substantially complete, then Engineer will, within said 14 days, execute and deliver to Owner and Contractor a final certificate of Substantial Completion (with a revised punch list of items to be completed or corrected) reflecting such changes from the preliminary certificate as Engineer believes justified after consideration of any objections from Owner.
- D. At the time of receipt of the preliminary certificate of Substantial Completion, Owner and Contractor will confer regarding Owner's use or occupancy of the Work following Substantial Completion, review the builder's risk insurance policy with respect to the end of the builder's risk coverage, and confirm the transition to coverage of the Work under a permanent property insurance policy held by Owner. Unless Owner and Contractor agree otherwise in writing, Owner shall bear responsibility for security, operation, protection of the Work, property insurance, maintenance, heat, and utilities upon Owner's use or occupancy of the Work.
- E. After Substantial Completion the Contractor shall promptly begin work on the punch list of items to be completed or corrected prior to final payment. In appropriate cases Contractor may submit monthly Applications for Payment for completed punch list items, following the progress payment procedures set forth above.

- F. Owner shall have the right to exclude Contractor from the Site after the date of Substantial Completion subject to allowing Contractor reasonable access to remove its property and complete or correct items on the punch list.

15.04 *Partial Use or Occupancy*

- A. Prior to Substantial Completion of all the Work, Owner may use or occupy any substantially completed part of the Work which has specifically been identified in the Contract Documents, or which Owner, Engineer, and Contractor agree constitutes a separately functioning and usable part of the Work that can be used by Owner for its intended purpose without significant interference with Contractor's performance of the remainder of the Work, subject to the following conditions:
 - 1. At any time, Owner may request in writing that Contractor permit Owner to use or occupy any such part of the Work that Owner believes to be substantially complete. If and when Contractor agrees that such part of the Work is substantially complete, Contractor, Owner, and Engineer will follow the procedures of Paragraph 15.03.A through 15.03.E for that part of the Work.
 - 2. At any time, Contractor may notify Owner and Engineer in writing that Contractor considers any such part of the Work substantially complete and request Engineer to issue a certificate of Substantial Completion for that part of the Work.
 - 3. Within a reasonable time after either such request, Owner, Contractor, and Engineer shall make an inspection of that part of the Work to determine its status of completion. If Engineer does not consider that part of the Work to be substantially complete, Engineer will notify Owner and Contractor in writing giving the reasons therefor. If Engineer considers that part of the Work to be substantially complete, the provisions of Paragraph 15.03 will apply with respect to certification of Substantial Completion of that part of the Work and the division of responsibility in respect thereof and access thereto.
 - 4. No use or occupancy or separate operation of part of the Work may occur prior to compliance with the requirements of Paragraph 6.04 regarding builder's risk or other property insurance.

15.05 *Final Inspection*

- A. Upon written notice from Contractor that the entire Work or an agreed portion thereof is complete, Engineer will promptly make a final inspection with Owner and Contractor and will notify Contractor in writing of all particulars in which this inspection reveals that the Work, or agreed portion thereof, is incomplete or defective. Contractor shall immediately take such measures as are necessary to complete such Work or remedy such deficiencies.

15.06 *Final Payment*

A. *Application for Payment*

- 1. After Contractor has, in the opinion of Engineer, satisfactorily completed all corrections identified during the final inspection and has delivered, in accordance with the Contract Documents, all maintenance and operating instructions, schedules, guarantees, bonds, certificates or other evidence of insurance, certificates of inspection, annotated record documents (as provided in Paragraph 7.12), and other documents, Contractor may make application for final payment.

2. The final Application for Payment must be accompanied (except as previously delivered) by:
 - a. all documentation called for in the Contract Documents;
 - b. consent of the surety, if any, to final payment;
 - c. satisfactory evidence that all title issues have been resolved such that title to all Work, materials, and equipment has passed to Owner free and clear of any Liens or other title defects, or will so pass upon final payment.
 - d. a list of all duly pending Change Proposals and Claims; and
 - e. complete and legally effective releases or waivers (satisfactory to Owner) of all Lien rights arising out of the Work, and of Liens filed in connection with the Work.
 3. In lieu of the releases or waivers of Liens specified in Paragraph 15.06.A.2 and as approved by Owner, Contractor may furnish receipts or releases in full and an affidavit of Contractor that: (a) the releases and receipts include all labor, services, material, and equipment for which a Lien could be filed; and (b) all payrolls, material and equipment bills, and other indebtedness connected with the Work for which Owner might in any way be responsible, or which might in any way result in liens or other burdens on Owner's property, have been paid or otherwise satisfied. If any Subcontractor or Supplier fails to furnish such a release or receipt in full, Contractor may furnish a bond or other collateral satisfactory to Owner to indemnify Owner against any Lien, or Owner at its option may issue joint checks payable to Contractor and specified Subcontractors and Suppliers.
- B. *Engineer's Review of Final Application and Recommendation of Payment:* If, on the basis of Engineer's observation of the Work during construction and final inspection, and Engineer's review of the final Application for Payment and accompanying documentation as required by the Contract Documents, Engineer is satisfied that the Work has been completed and Contractor's other obligations under the Contract have been fulfilled, Engineer will, within 10 days after receipt of the final Application for Payment, indicate in writing Engineer's recommendation of final payment and present the final Application for Payment to Owner for payment. Such recommendation will account for any set-offs against payment that are necessary in Engineer's opinion to protect Owner from loss for the reasons stated above with respect to progress payments. Otherwise, Engineer will return the Application for Payment to Contractor, indicating in writing the reasons for refusing to recommend final payment, in which case Contractor shall make the necessary corrections and resubmit the Application for Payment.
- C. *Notice of Acceptability:* In support of its recommendation of payment of the final Application for Payment, Engineer will also give written notice to Owner and Contractor that the Work is acceptable, subject to stated limitations in the notice and to the provisions of Paragraph 15.07.
- D. *Completion of Work:* The Work is complete (subject to surviving obligations) when it is ready for final payment as established by the Engineer's written recommendation of final payment and issuance of notice of the acceptability of the Work.
- E. *Final Payment Becomes Due:* Upon receipt from Engineer of the final Application for Payment and accompanying documentation, Owner shall set off against the amount recommended by Engineer for final payment any further sum to which Owner is entitled, including but not

limited to set-offs for liquidated damages and set-offs allowed under the provisions of this Contract with respect to progress payments. Owner shall pay the resulting balance due to Contractor within 30 days of Owner's receipt of the final Application for Payment from Engineer.

15.07 *Waiver of Claims*

- A. By making final payment, Owner waives its claim or right to liquidated damages or other damages for late completion by Contractor, except as set forth in an outstanding Claim, appeal under the provisions of Article 17, set-off, or express reservation of rights by Owner. Owner reserves all other claims or rights after final payment.
- B. The acceptance of final payment by Contractor will constitute a waiver by Contractor of all claims and rights against Owner other than those pending matters that have been duly submitted as a Claim, or appealed under the provisions of Article 17.

15.08 *Correction Period*

- A. If within one year after the date of Substantial Completion (or such longer period of time as may be prescribed by the Supplementary Conditions or the terms of any applicable special guarantee required by the Contract Documents), Owner gives Contractor written notice that any Work has been found to be defective, or that Contractor's repair of any damages to the Site or adjacent areas has been found to be defective, then after receipt of such notice of defect Contractor shall promptly, without cost to Owner and in accordance with Owner's written instructions:
 - 1. correct the defective repairs to the Site or such adjacent areas;
 - 2. correct such defective Work;
 - 3. remove the defective Work from the Project and replace it with Work that is not defective, if the defective Work has been rejected by Owner, and
 - 4. satisfactorily correct or repair or remove and replace any damage to other Work, to the work of others, or to other land or areas resulting from the corrective measures.
- B. Owner shall give any such notice of defect within 60 days of the discovery that such Work or repairs is defective. If such notice is given within such 60 days but after the end of the correction period, the notice will be deemed a notice of defective Work under Paragraph 7.17.B.
- C. If, after receipt of a notice of defect within 60 days and within the correction period, Contractor does not promptly comply with the terms of Owner's written instructions, or in an emergency where delay would cause serious risk of loss or damage, Owner may have the defective Work corrected or repaired or may have the rejected Work removed and replaced. Contractor shall pay all costs, losses, and damages (including but not limited to all fees and charges of engineers, architects, attorneys, and other professionals and all court or arbitration or other dispute resolution costs) arising out of or relating to such correction or repair or such removal and replacement (including but not limited to all costs of repair or replacement of work of others). Contractor's failure to pay such costs, losses, and damages within 10 days of invoice from Owner will be deemed the start of an event giving rise to a Claim under Paragraph 12.01.B, such that any related Claim must be brought within 30 days of the failure to pay.

- D. In special circumstances where a particular item of equipment is placed in continuous service before Substantial Completion of all the Work, the correction period for that item may start to run from an earlier date if so provided in the Specifications.
- E. Where defective Work (and damage to other Work resulting therefrom) has been corrected or removed and replaced under this paragraph, the correction period hereunder with respect to such Work will be extended for an additional period of one year after such correction or removal and replacement has been satisfactorily completed.
- F. Contractor's obligations under this paragraph are in addition to all other obligations and warranties. The provisions of this paragraph are not to be construed as a substitute for, or a waiver of, the provisions of any applicable statute of limitation or repose.

ARTICLE 16—SUSPENSION OF WORK AND TERMINATION

16.01 *Owner May Suspend Work*

- A. At any time and without cause, Owner may suspend the Work or any portion thereof for a period of not more than 90 consecutive days by written notice to Contractor and Engineer. Such notice will fix the date on which Work will be resumed. Contractor shall resume the Work on the date so fixed. Contractor shall be entitled to an adjustment in the Contract Price or an extension of the Contract Times directly attributable to any such suspension. Any Change Proposal seeking such adjustments must be submitted no later than 30 days after the date fixed for resumption of Work.

16.02 *Owner May Terminate for Cause*

- A. The occurrence of any one or more of the following events will constitute a default by Contractor and justify termination for cause:
 1. Contractor's persistent failure to perform the Work in accordance with the Contract Documents (including, but not limited to, failure to supply sufficient skilled workers or suitable materials or equipment, or failure to adhere to the Progress Schedule);
 2. Failure of Contractor to perform or otherwise to comply with a material term of the Contract Documents;
 3. Contractor's disregard of Laws or Regulations of any public body having jurisdiction; or
 4. Contractor's repeated disregard of the authority of Owner or Engineer.
- B. If one or more of the events identified in Paragraph 16.02.A occurs, then after giving Contractor (and any surety) 10 days' written notice that Owner is considering a declaration that Contractor is in default and termination of the Contract, Owner may proceed to:
 1. declare Contractor to be in default, and give Contractor (and any surety) written notice that the Contract is terminated; and
 2. enforce the rights available to Owner under any applicable performance bond.
- C. Subject to the terms and operation of any applicable performance bond, if Owner has terminated the Contract for cause, Owner may exclude Contractor from the Site, take possession of the Work, incorporate in the Work all materials and equipment stored at the Site or for which Owner has paid Contractor but which are stored elsewhere, and complete the Work as Owner may deem expedient.

- D. Owner may not proceed with termination of the Contract under Paragraph 16.02.B if Contractor within 7 days of receipt of notice of intent to terminate begins to correct its failure to perform and proceeds diligently to cure such failure.
- E. If Owner proceeds as provided in Paragraph 16.02.B, Contractor shall not be entitled to receive any further payment until the Work is completed. If the unpaid balance of the Contract Price exceeds the cost to complete the Work, including all related claims, costs, losses, and damages (including but not limited to all fees and charges of engineers, architects, attorneys, and other professionals) sustained by Owner, such excess will be paid to Contractor. If the cost to complete the Work including such related claims, costs, losses, and damages exceeds such unpaid balance, Contractor shall pay the difference to Owner. Such claims, costs, losses, and damages incurred by Owner will be reviewed by Engineer as to their reasonableness and, when so approved by Engineer, incorporated in a Change Order. When exercising any rights or remedies under this paragraph, Owner shall not be required to obtain the lowest price for the Work performed.
- F. Where Contractor's services have been so terminated by Owner, the termination will not affect any rights or remedies of Owner against Contractor then existing or which may thereafter accrue, or any rights or remedies of Owner against Contractor or any surety under any payment bond or performance bond. Any retention or payment of money due Contractor by Owner will not release Contractor from liability.
- G. If and to the extent that Contractor has provided a performance bond under the provisions of Paragraph 6.01.A, the provisions of that bond will govern over any inconsistent provisions of Paragraphs 16.02.B and 16.02.D.

16.03 *Owner May Terminate for Convenience*

- A. Upon 7 days' written notice to Contractor and Engineer, Owner may, without cause and without prejudice to any other right or remedy of Owner, terminate the Contract. In such case, Contractor shall be paid for (without duplication of any items):
 - 1. completed and acceptable Work executed in accordance with the Contract Documents prior to the effective date of termination, including fair and reasonable sums for overhead and profit on such Work;
 - 2. expenses sustained prior to the effective date of termination in performing services and furnishing labor, materials, or equipment as required by the Contract Documents in connection with uncompleted Work, plus fair and reasonable sums for overhead and profit on such expenses; and
 - 3. other reasonable expenses directly attributable to termination, including costs incurred to prepare a termination for convenience cost proposal.
- B. Contractor shall not be paid for any loss of anticipated profits or revenue, post-termination overhead costs, or other economic loss arising out of or resulting from such termination.

16.04 *Contractor May Stop Work or Terminate*

- A. If, through no act or fault of Contractor, (1) the Work is suspended for more than 90 consecutive days by Owner or under an order of court or other public authority, or (2) Engineer fails to act on any Application for Payment within 30 days after it is submitted, or (3) Owner fails for 30 days to pay Contractor any sum finally determined to be due, then Contractor may, upon 7 days' written notice to Owner and Engineer, and provided Owner or

Engineer do not remedy such suspension or failure within that time, terminate the contract and recover from Owner payment on the same terms as provided in Paragraph 16.03.

- B. In lieu of terminating the Contract and without prejudice to any other right or remedy, if Engineer has failed to act on an Application for Payment within 30 days after it is submitted, or Owner has failed for 30 days to pay Contractor any sum finally determined to be due, Contractor may, 7 days after written notice to Owner and Engineer, stop the Work until payment is made of all such amounts due Contractor, including interest thereon. The provisions of this paragraph are not intended to preclude Contractor from submitting a Change Proposal for an adjustment in Contract Price or Contract Times or otherwise for expenses or damage directly attributable to Contractor's stopping the Work as permitted by this paragraph.

ARTICLE 17—FINAL RESOLUTION OF DISPUTES

17.01 *Methods and Procedures*

- A. *Disputes Subject to Final Resolution:* The following disputed matters are subject to final resolution under the provisions of this article:
1. A timely appeal of an approval in part and denial in part of a Claim, or of a denial in full, pursuant to Article 12; and
 2. Disputes between Owner and Contractor concerning the Work, or obligations under the Contract Documents, that arise after final payment has been made.
- B. *Final Resolution of Disputes:* For any dispute subject to resolution under this article, Owner or Contractor may:
1. elect in writing to invoke the dispute resolution process provided for in the Supplementary Conditions;
 2. agree with the other party to submit the dispute to another dispute resolution process; or
 3. If no dispute resolution process is provided for in the Supplementary Conditions or mutually agreed to, give written notice to the other party of the intent to submit the dispute to a court of competent jurisdiction.

See SC-17.02

ARTICLE 18—MISCELLANEOUS

18.01 *Giving Notice*

- A. Whenever any provision of the Contract requires the giving of written notice to Owner, Engineer, or Contractor, it will be deemed to have been validly given only if delivered:
1. in person, by a commercial courier service or otherwise, to the recipient's place of business;
 2. by registered or certified mail, postage prepaid, to the recipient's place of business; or
 3. by e-mail to the recipient, with the words "Formal Notice" or similar in the e-mail's subject line.

18.02 *Computation of Times*

- A. When any period of time is referred to in the Contract by days, it will be computed to exclude the first and include the last day of such period. If the last day of any such period falls on a Saturday or Sunday or on a day made a legal holiday by the law of the applicable jurisdiction, such day will be omitted from the computation.

18.03 *Cumulative Remedies*

- A. The duties and obligations imposed by these General Conditions and the rights and remedies available hereunder to the parties hereto are in addition to, and are not to be construed in any way as a limitation of, any rights and remedies available to any or all of them which are otherwise imposed or available by Laws or Regulations, by special warranty or guarantee, or by other provisions of the Contract. The provisions of this paragraph will be as effective as if repeated specifically in the Contract Documents in connection with each particular duty, obligation, right, and remedy to which they apply.

18.04 *Limitation of Damages*

- A. With respect to any and all Change Proposals, Claims, disputes subject to final resolution, and other matters at issue, neither Owner nor Engineer, nor any of their officers, directors, members, partners, employees, agents, consultants, or subcontractors, shall be liable to Contractor for any claims, costs, losses, or damages sustained by Contractor on or in connection with any other project or anticipated project.

18.05 *No Waiver*

- A. A party's non-enforcement of any provision will not constitute a waiver of that provision, nor will it affect the enforceability of that provision or of the remainder of this Contract.

18.06 *Survival of Obligations*

- A. All representations, indemnifications, warranties, and guarantees made in, required by, or given in accordance with the Contract, as well as all continuing obligations indicated in the Contract, will survive final payment, completion, and acceptance of the Work or termination of the Contract or of the services of Contractor.

18.07 *Controlling Law*

- A. This Contract is to be governed by the law of the state in which the Project is located.

18.08 *Assignment of Contract*

- A. Unless expressly agreed to elsewhere in the Contract, no assignment by a party to this Contract of any rights under or interests in the Contract will be binding on the other party without the written consent of the party sought to be bound; and, specifically but without limitation, money that may become due and money that is due may not be assigned without such consent (except to the extent that the effect of this restriction may be limited by law), and unless specifically stated to the contrary in any written consent to an assignment, no assignment will release or discharge the assignor from any duty or responsibility under the Contract.

18.09 *Successors and Assigns*

- A. Owner and Contractor each binds itself, its successors, assigns, and legal representatives to the other party hereto, its successors, assigns, and legal representatives in respect to all covenants, agreements, and obligations contained in the Contract Documents.

18.10 *Headings*

- A. Article and paragraph headings are inserted for convenience only and do not constitute parts of these General Conditions.

END OF GENERAL CONDITIONS

SECTION 10 - SUPPLEMENTARY CONDITIONS

TABLE OF CONTENTS

	Page
Article 1— Definitions and Terminology.....	1
Article 2— Preliminary Matters	1
Article 3— Contract Documents: Intent, Requirements, Reuse	1
Article 4— Commencement and Progress of the Work	2
Article 5— Site, Subsurface and Physical Conditions, Hazardous Environmental Conditions.....	2
Article 6— Bonds and Insurance	4
Article 7— Contractor’s Responsibilities	5
Article 8— Other Work at the Site	9
Article 9— Owner’s Responsibilities	9
Article 10— Engineer’s Status During Construction	9
Article 11— Changes to the Contract	10
Article 12— Claims	10
Article 13— Cost of Work; Allowances, Unit Price Work.....	11
Article 14— Tests and Inspections; Correction, Removal, or Acceptance of Defective Work.....	11
Article 15— Payments to Contractor, Set Offs; Completions; Correction Period	11
Article 16— Suspension of Work and Termination	11
Article 17— Final Resolutions of Disputes	11
Article 18— Miscellaneous	12

These Supplementary Conditions amend or supplement EJCDC® C-700, Standard General Conditions of the Construction Contract (2018). The General Conditions remain in full force and effect except as amended.

The terms used in these Supplementary Conditions have the meanings stated in the General Conditions. Additional terms used in these Supplementary Conditions have the meanings stated below, which are applicable to both the singular and plural thereof.

The address system used in these Supplementary Conditions is the same as the address system used in the General Conditions, with the prefix "SC" added—for example, "Paragraph SC-4.05."

Article 1—DEFINITIONS AND TERMINOLOGY

SC-1.01. Renumber Paragraph 1.01.A.38 to 1.01.A.38.a, and add the following new paragraph:

- A. 1.01.A.38.b. Specialist—The term Specialist refers to a person, partnership, firm, or corporation of established reputation (or if newly organized, whose personnel have previously established a reputation in the same field), which is regularly engaged in, and which maintains a regular force of workers skilled in either (as applicable) manufacturing or fabricating items required by the Contract Documents, or otherwise performing Work required by the Contract Documents. Where the Specifications require the installation by a Specialist, that term shall also be deemed to mean either the manufacturer of the item, a person, partnership, firm, or corporation licensed by the manufacturer, or a person, partnership, firm, or corporation who will perform the Work under the manufacturer's direct supervision.

Article 2—PRELIMINARY MATTERS

2.01 *Delivery of Bonds and Evidence of Insurance*

SC-2.01 Delete Paragraphs 2.01.B. and C. in their entirety and insert the following in their place:

- B. *Evidence of Contractor's Insurance:* When Contractor delivers the signed counterparts of the Agreement to Owner, Contractor shall also deliver to Owner copies of the policies (including all endorsements, and identification of applicable self-insured retentions and deductibles) of insurance required to be provided by Contractor in this Contract. Contractor may block out (redact) any confidential premium or pricing information contained in any policy or endorsement furnished under this provision.

2.02 *Copies of Documents*

SC-2.02 Amend Paragraph 2.02.A. to read as follows:

Owner shall furnish to Contractor hard copies of the Contract Documents as are reasonably necessary, with a maximum of five (5) sets, for execution of the work. Additional copies will be furnished, upon request, at the cost of production.

Article 3—CONTRACT DOCUMENTS: INTENT, REQUIREMENTS, REUSE

3.01 *Intent*

SC-3.01 Delete Paragraph 3.01.C in its entirety.

Article 4—COMMENCEMENT AND PROGRESS OF THE WORK

4.01 *Commencement of Contract Times; Notice to Proceed*

SC-4.01. Delete the third sentence of Paragraph 4.01.A in its entirety.

4.03 *Reference Points*

SC-4.03. Delete the first sentence of Paragraph 4.03.A in its entirety.

4.04 *Progress Schedule*

SC-4.04. Add the following new paragraphs to the end of Paragraph 4.04.B:

4.04.C. The Contractor shall submit a construction schedule within ten (10) days of Notice of Award. Thereafter, the Contractor shall submit an updated construction schedule every month.

4.04.D. Contractor shall comply with the requirements of Washoe County Development Code Division 4, Article 414, "Noise and Lighting Standards" in the performance of the Work. However, NO equipment operation, including "warm up," shall occur prior to 8:00 a.m. nor after 7:00 p.m., excluding Saturdays, Sundays, and holidays recognized by Owner. The Engineer shall have final say as to the adequacy of the equipment for other than day use, and no additional payment shall be made to Contractor for the rental of equipment to meet these limitations.

Article 5—SITE, SUBSURFACE AND PHYSICAL CONDITIONS, HAZARDOUS ENVIRONMENTAL CONDITIONS

5.02 *Use of Site and Other Areas*

SC-5.02. Add the following language to the end of Paragraph 5.02.A.1:

Contractor shall not enter upon nor use property not under Owner control until appropriate easements have been executed and a copy is on file at the Site.

5.03 *Subsurface and Physical Conditions*

SC-5.03. Delete Paragraph 5.03.C in its entirety and insert the following in its place:

5.03.C Those reports known to Owner of explorations and tests of subsurface conditions at or adjacent to the Site is as follows:

5.03.C.1. No subsurface explorations and/or tests have been performed. The Contractor shall have full responsibility with respect to subsurface conditions at the sites.

SC-5.03 Add the following new paragraphs immediately after Paragraph 5.03.C:

5.03.D. Contractor may examine copies of reports and drawings identified immediately above that were not included with the Bidding Documents at 1220 Sweetwater Road, Incline Village, NV during regular business hours, or may request copies from Engineer at the cost of reproduction.

5.03.E. The Contractor shall verify the locations and dimensions of all existing equipment and structures, whether shown on the plans or not, and shall have full responsibility with respect to physical conditions in or relating to such structures and equipment.

5.03.F. Contractor is advised that the Lake Tahoe basin is known for large rocks and boulders buried under the surface, and it is common to find boulders within the work area.

5.04 *Differing Subsurface or Physical Conditions*

SC-5.04 Delete Paragraph 5.04.A in its entirety and insert the following in its place:

5.04.A. Notice by Contractor: If Contractor believes that any subsurface condition that is uncovered or revealed at the Site differs materially from conditions ordinarily encountered in the Tahoe Basin and generally recognized as inherent in work of the character provided for in the Contract Documents; then Contractor shall, promptly after becoming aware thereof and before further disturbing the subsurface conditions or performing any Work in connection therewith (except in an emergency as required by Paragraph 7.15), notify Owner and Engineer in writing about such condition. Contractor shall not further disturb such condition or perform any Work in connection therewith (except with respect to an emergency) until receipt of a written statement permitting Contractor to do so. Owner shall issue a written statement to Contractor regarding the subsurface or physical condition in question, addressing the resumption or continuation of Work in connection with such condition, indicating whether any change in the Drawings or Specifications will be made. Contractor shall not be entitled to any adjustment in the Contract Price or Contract Times with respect to a subsurface or physical condition if:

5.04.A.2.a. Contractor knew of the existence of such condition at the time Contractor made a commitment to Owner with respect to Contract Price and Contract Times by becoming bound under a negotiated contract, or otherwise; or

5.04.A.2.b. The existence of such condition reasonably could have been discovered or revealed as a result of any examination, investigation, exploration, test, or study of the Site and contiguous areas expressly required by the Contract Documents to be conducted by or for Contractor prior to Contractor's making such commitment; or

5.04.A.2.c. Contractor failed to give the written notice as required by SC-5.04.A.

SC-5.04 Delete Paragraph 5.04.E.4 in its entirety and insert the following in its place:

5.04.E.4 Contractor may submit a Change Proposal regarding its entitlement to or the amount or extent of any adjustment in the Contract Price or Contract Times, no later than 7 days after Owner's issuance of the Owner's written statement to Contractor regarding the subsurface or physical condition in question-

5.06 *Hazardous Environmental Conditions*

SC-5.06. Delete Paragraphs 5.06.A and Paragraph 5.06.B in their entirety and insert the following in their place:

5.06.A. No reports or drawings related to Hazardous Environmental Conditions are known to Owner.

Article 6—**BONDS AND INSURANCE**

6.02 *Insurance—General Provisions*

SC-6.02. Add the following new paragraph immediately after Paragraph 6.02.A:

6.02.A.1. Surety and insurance companies from which the bonds and insurance for this Project are purchased shall have an A.M. Best’s rating of no less “A (FSC-VII).”

SC-6.02. Add the following new paragraph immediately after Paragraph 6.02.J:

6.02.K. Contractor shall furnish properly executed certificates of insurance to Owner prior to commencement of Work under this agreement. Such certificates shall: clearly evidence all coverage required herein, including specific evidence of an endorsement naming Owner and Engineer as an additional insured, as well as all exclusions to the policies; indicate whether coverage provided is on a claims-made or occurrence basis; provide that such insurance shall not be materially changed, terminated or allowed to expire except on 30 days prior written notice to Owner; and be forwarded to: IVGID Engineering Division, 1220 Sweetwater Road, Incline Village, NV 89451. Any failure to comply with reporting provisions of the policies shall not affect coverage provided to the District, its officers, employees or volunteers.

6.03 *Contractor’s Insurance*

SC-6.03. Add the following new paragraphs immediately following Paragraph 6.03.A:

6.03.A.1. Workman's Compensation: It is understood and agreed that there shall be no Industrial Insurance coverage provided for the Contractor or any Subcontractor by the District; and in view of NRS 616.280 and 617.210 requiring that Contractor comply with the provisions of Chapters 616 and 617 of NRS, Contractor shall, before commencing work under the provisions of this Agreement, furnish to the District a Certificate of Insurance from an admitted insurance company in the State of Nevada.

6.03.A.2. General Liability: Contractor shall purchase General Liability including appropriate Auto Liability with a \$2,000,000 combined single limit per occurrence, for bodily injury, personal injury and property damage.

6.03.A.3. Commercial Insurance: Contractor shall procure and maintain for the duration of the Contract, insurance against claims for injuries to persons or damages to property, which may arise from or in connection with the performance of the work hereunder by the Contractor, his/her agents, representatives, employees, or subcontractors. Contractor shall purchase General Liability, Auto Liability, Workers' Compensation, and Professional Liability Insurance (if applicable) coverage as required. Contractor shall have a Certificate of Insurance issued to the Incline Village General Improvement District naming it as additional insured, indicating coverage types amounts and duration of the policy. All certificates shall provide for a minimum written notice of thirty (30) days to be provided to District in the event of material change, termination or non-renewal by either Contractor or carrier.

SC-6.03. Add the following new paragraph immediately following Paragraph 6.03.C:

6.03.D. Deductible and/or Self-Insured Retention (SIR)

1. Any deductible and/or SIR must be declared to and approved by the Owner. The District reserves the right to request additional documentation (financial or otherwise) prior to giving its approval of the deductible and/or SIR and prior to executing the underlying Agreement. Any changes to the deductible and/or SIR made during the term of this Agreement or during the term of any policy, just be approved by the Owner prior to the change taking effective.

6.04 *Builder's Risk and Other Property Insurance*

SC-6.04 Delete Paragraph 6.04.A and insert the following in its place:

- A. Contractor shall purchase and maintain builder's risk insurance upon the Work on a completed value basis, in the amount of the Work's full insurable replacement cost (subject to such deductible amounts as may be provided in the Supplementary Conditions or required by Laws and Regulations). The specific requirements applicable to the builder's risk insurance are set forth in the Supplementary Conditions.

Article 7—**CONTRACTOR'S RESPONSIBILITIES**

7.01 Add the following after paragraph 7.01B

7.01.C **Means and methods.** The contractor shall notify the Owner and Engineer immediately upon a proposed change to the means and methods for completing the project work if the proposed means and methods are different than as allowed for in the contract documents as accepted at the bid award. The Contractor shall notify the owner in writing PRIOR to starting any worked by means and methods that vary from the original documents.

7.03 Add the following after paragraph 7.03.C:

7.03.D **Working Hours.** Working hours shall be limited to 8:00 a.m. to 5:30 p.m. Monday through Friday unless otherwise directed by Owner. No equipment operation, including "warm up", refueling or maintenance, shall occur outside these hours. Contractor shall not permit the performance of work outside these hours without Owner's written consent given after prior written notice to Engineer.

CONTRACTOR shall comply with all local and regional Noise Ordinances in the performance of the work. The ENGINEER shall have final say as to the adequacy of the equipment for other than day use and no additional payment shall be made to CONTRACTOR for the rental of equipment to meet these limitations.

Documented instances of noise producing activities by the CONTRACTOR outside of the permitted working hours shall result in a written warning for the first offense and a \$500 penalty for each subsequent offense.

CONTRACTOR understands that water service to any property cannot be interrupted for more than four (4) hours. No interruption is allowed on weekends or holidays. Water service interruptions to businesses shall not occur during business hours without consent of the business owner. CONTRACTOR must notify IVGID at least 72-hours in advance of disrupting water service and any affected resident(s) or businesses at least 48 hours in advance. CONTRACTOR is responsible for notification to affected customers and businesses. IVGID will supply CONTRACTOR with a list of addresses to notify, and supply door hangers. CONTRACTOR is responsible for filling out each door hanger and hanging or securing the notices on the

front door of each residence or business. CONTRACTOR will make every effort to speak with the customer(s) in person regarding the interruption of service. These requirements may necessitate work during the weekends or evenings. No additional payment will be made to CONTRACTOR because of these conditions.

7.04 *Services, Materials, and Equipment*

SC-7.04. Add the following new paragraphs to the end of Paragraph 7.04.C:

7.04.D. Any materials or work not meeting Contract requirements shall be resubmitted to the Engineer or reconstructed at the Contractor's expense.

7.04.E. Contractor is to be aware of District's Ordinance 1, the Solid Waste Ordinance, and pay specific attention to Section 4.5, Dumpster Use, Location and Enclosure. Any construction dumpster on the job site that is not properly enclosed shall be a fully locking roll-top, and is to remain locked and secured at all times.

7.07 *Services, Materials, and Equipment*

SC-7.07. Add the following language at the end of Paragraph 7.07.A:

Contractor shall perform a minimum of 50 percent of the onsite labor with its own employees.

7.09 *Permits*

SC-7.09. Add the following new paragraphs after Paragraph 7.09.A:

7.09.B. All permits, licenses, and inspection fees necessary for prosecution and completion of the work shall be secured and paid for by the Contractor, unless otherwise specified:

1. The CONTRACTOR shall conduct all Work in accordance with the Tahoe Regional Planning Agency (TRPA) Code of Ordinances, whether shown on the plans or not. If the CONTRACTOR fails to follow any requirements which result in a penalty by TRPA to the OWNER, the CONTRACTOR shall be responsible for any costs associated with the penalty.
2. Contractor shall be responsible for dust control throughout all phases of construction. All local ordinances regarding dust control shall be complied with, including the Washoe County Health Department requirements. The responsibility of obtaining the regulations and requirements, including obtaining a Dust Control Permit, if required, and full compliance with such ordinances is solely that of the Contractor.
3. Where required, Contractor to acquire Washoe County Street Cut permits from Washoe County Road Department prior to starting any work. Owner will pay all fees associated with acquiring this permit. Contractor will pay all penalties associated with this permit.

7.11 *Laws and Regulations*

SC-7.11. Add the following new paragraphs after Paragraph 7.11.C:

7.11.D. While not intended to be inclusive of all Laws or Regulations for which Contractor may be responsible under Paragraph 7.11, the following Laws or Regulations are included as mandated by statute or for the convenience of Contractor:

7.11.D.1. Prevailing Wage Rates:

7.11.D.1.a. Pursuant to NRS 338.020, hourly and daily rate of wages must not be less than prevailing wage in Washoe County and, when applicable, Davis-Bacon wage

determinations. The most current schedule of prevailing wage rates as of contract award date, as determined by the Labor Commission of the State of Nevada and, if applicable, Davis-Bacon rates, is included herein and shall be posted onsite.

7.11.D.1.b. Contractor to provide photographic proof of wage rate posting at the job site.

7.11.D.2. Fair Employment Practices:

7.11.D.2.a. Pursuant to NRS 338.125, in connection with performance of Work under these Contract Documents, Contractor agrees not to discriminate against any employee or applicant for employment because of race, creed, color, national origin, sex, sexual orientation, or age. Such agreement shall include, but not be limited to, the following: Employment, upgrading, demotion or transfer, recruitment or recruitment advertising, layoff or termination, rates of pay or other forms of compensation, and selection for training, including apprenticeship.

7.11.D.2.b. Contractor further agrees to insert this provision in all subcontracts thereunder except subcontracts for standard commercial supplies or raw materials.

7.11.D.2.c. Any violation of such provision by a Contractor shall constitute a material breach of Contract.

7.11.D.3. Preferential Employment:

7.11.D.3.a. Pursuant to NRS 338.130, Contractor shall give preference in hiring, the qualifications of the applicants being equal: (a) First: To honorably discharged soldiers, sailors, and marines of the United States who are citizens of the State of Nevada; and (b) Second: To other citizens of the State of Nevada.

7.11.D.3.b. If the provisions of NRS 338.130 are not complied with by Contractor, Contract shall be void, and any failure or refusal to comply with any of the provisions of this section shall render any such Contract void.

7.11.D.4, SB 207, Apprenticeship Utilization Act

Contractor shall comply with Chapter 527, Statutes of Nevada 2019, enacted by the Nevada Legislature by passage of Senate Bill 207, and as amended by Senate Bill 82, passed in 2023. Refer to labor.nv.gov for further information.

7.11.E. The Contractor shall submit all certified payroll payrolls electronically via the internet into the Owner's contracted tracking system LCPtracker. This requirement will apply to every lower-tier subcontractor and vendor required to provide certified payroll reports by NRS 338.010 to 338.090 inclusive. Upon issuance of the Notice to Proceed, the Owner will provide the Contractor with the website addresses and a Login Identification with a password to access the payroll system. The Contractor is responsible for the set-up of access to the payroll system to their subcontractors. Training to utilize the system is available on the LCPtracker website.

7.13 *Safety and Protection*

SC-7.13. Add the following new paragraph immediately after 7.13.G:

7.13.G.1. The following Owner safety program(s) are applicable to the Work:

1. The Contractor shall be responsible for initiating, maintaining, and supervising all safety precautions and programs in connection with the Work to be performed under this Agreement. The Contractor shall take all necessary precautions for the

safety of, and shall provide all necessary protection to prevent damage, injury, or loss to:

- a. All employees and all other persons who may be affected by the operations of this Agreement.
 - b. All materials and equipment whether in storage on or off the construction site.
 - c. Other property at the construction site or adjacent to the construction site, including but not limited to trees, shrubs, lawns, walks, pavements, roadways, structures, and utilities not designated for removal, relocation, or replacement in the course of construction.
2. The Contractor shall comply with all applicable laws, ordinances, rules, regulations, and others of any public authority having jurisdiction for the safety of persons or property or to protect them from damage, injury or loss. The Contractor shall erect and maintain, as required by existing conditions and progress on the project, all necessary safeguards for safety and protection, including posting danger signs and other warnings against hazards, promulgating safety regulations, and notifying owners and users of adjacent utilities. Contractor shall comply with OSHA's Hazard Communication Standards.
 3. The Contractor shall designate a responsible member of his/her organization at the construction site whose duty shall be the prevention of accidents. This person shall be the Contractor's superintendent unless otherwise designated in writing by the Contractor to the Owner.
 4. The Contractor shall be responsible for initiating, maintaining, and supervising all safety precautions and programs in connection with any confined space entries to be performed during completion of work under this Agreement. Contractor responsibilities include but are not limited to:
 - a. Review and be familiar with the Owner's online written Confined Space program.
 - b. Review documented information about Owner's confined spaces in which entry is intended. This information includes identified hazards for each permit-required confined space. The Contractor shall be responsible for performing their own hazard assessment prior to any confined space entry.
 - c. Contractor shall have their own confined space entry program. Upon request of the Owner, Contractor will provide a statement confirming they are in compliance with their confined space entry program including requirements for confined space training for employees associated with the Work.
 - d. Be responsible for following all confined space requirements established by the provisions in CFR 1910.146 and its chapters.
 - e. Coordinate entry operations with the Owner when employees from the Contractor will be working in or near confined spaces.

- f. Debrief the Owner on any hazards confronted or created at the completion of entry operations.
- g. Place signs stating, “Danger, Follow Confined Space Entry Procedures Before Entering” at each confined space to be entered. The Contractor shall never leave a confined space open or unattended.

7.18 *Indemnification*

SC-7.18. Add the following new paragraph immediately after Paragraph 7.18.B:

7.18.C. The Contractor agrees to hold harmless, indemnify and defend Owner, his employees, agents, consultants, or representatives from any loss or liability, financial or otherwise resulting from any claim, demand, suit, action or cause of action based on bodily injury, including death, or property damage, including damage to Contractor’s property caused by any action, either direct or passive, the omission, failure to act, or negligence on the part of the Contractor, his employees, agents, representatives or subcontractors arising out of the performance of work under these Contract Documents by the Contractor, or by others under the direction or supervision of the Contractor.

In determining the nature of the claim against Owner, the incident underlying the claim shall determine the nature of the claim, notwithstanding the form of the allegations against Owner.

In the event of a claim or lawsuit against Owner, Contractor shall reimburse Owner for cost of Owner's personnel in defending such actions. Reimbursement for the time spent by such personnel shall be the rate charged for such services by the private sector.

Article 8—OTHER WORK AT THE SITE

No suggested Supplementary Conditions in this Article.

Article 9—OWNER’S RESPONSIBILITIES

9.12 *Owner’s Site Representative*

SC-9.12 Add the following new paragraphs immediately after Paragraph 9.12 of the General Conditions:

9.13 *Owner as Resident Project Representative*

9.13.A. Owner may furnish Project representation during the construction period. The duties, responsibilities, and limitations of authority specified for Engineer in Article 10, Engineer’s Status During Construction, and elsewhere in the Contract Documents will be those of Owner.

9.13.B. In addition to the Resident Project Representative which may be furnished by Engineer, Owner may furnish an Owner’s Site representative to assist Engineer. The responsibilities, authorities, and limitations of authority of Owner’s Site representative will be as specified for Engineer’s Resident Project Representative.

Article 10—ENGINEER’S STATUS DURING CONSTRUCTION

10.05 Determinations for Unit Price Work

SC-10.05. Delete Paragraph 10.05 in its entirety and replace it with the following paragraph:

10.05. The Engineer will have the authority to determine the actual quantities and classifications of the items of Unit Price Work performed by the Contractor, and the written decisions of the Engineer on such matters will be final, binding on the Owner and Contractor, and not subject to appeal (except as modified by the Engineer to reflect changed factual conditions).

10.07 Limitations on Engineer's Authority and Responsibilities

SC-10.07. Add the following new paragraph after Paragraph 10.07.E:

10.07.F. Contractors, Subcontractors, Suppliers, and others on the Project, or their sureties, shall maintain no direct action against Engineer, its officers, employees, affiliated corporations, and subcontractors, for any Claim arising out of, in connection with, or resulting from the engineering services performed. Only the Owner will be the beneficiary of any undertaking by Engineer.

Article 11—CHANGES TO THE CONTRACT

11.03 Work Change Directives

SC-11.03B Delete Paragraphs 11.03.B.1 and 11.03.B.2 in their entirety and replace with the following sections:

1. If Contractor believes that an adjustment in Contract Times or Contract Price is necessary, then Contractor shall submit a Change Proposal seeking such an adjustment prior to starting the Work set out in the Work Change Directive.
2. If Owner believes that an adjustment in Contract Times or Contract Price is necessary, then Owner shall submit any claim seeking such an adjustment no later than 10 days after issuance of the Work Change Directive.

11.07 *Change of Contract Price*

SC-11.07. Add the following two new paragraphs after Paragraph 11.07.C:

11.07.D. In the event Contractor submits request for additional compensation as a result of a change or differing Site conditions, or as a result of delays, acceleration, or loss of productivity, Owner reserves right, upon written request, to audit and inspect Contractor's books and records relating to the Project. Upon written request for an audit, Contractor shall make its books and records available within 14 days of request. Owner shall specifically designate identity of auditor. As part of audit, Contractor shall make available its books and records relating to the Project, including but not limited to Bidding Documents, cost reports, payroll records, material invoices, subcontracts, purchase orders, daily timesheets, and daily diaries. Audit shall be limited to those cost items which are sought by Contractor in a change order or claim submission to Owner.

11.07.E. In absence of an approved contract change order or written authorization, the Contractor shall not be entitled to payment for any changed or Extra Work.

11.08 *Change of Contract Times*

SC-11.08. Add the following new paragraph immediately after Paragraph 11.08.B:

11.08.C. In absence of an approved contract change order or written authorization, the Contractor shall not be entitled to any adjustment of Contract time for any changed or Extra Work.

Article 12—**CLAIMS**

No suggested Supplementary Conditions in this Article.

Article 13—**COST OF WORK; ALLOWANCES, UNIT PRICE WORK**

No suggested Supplementary Conditions in this Article.

Article 14—**TESTS AND INSPECTIONS; CORRECTION, REMOVAL, OR ACCEPTANCE OF DEFECTIVE WORK**

No suggested Supplementary Conditions in this Article.

Article 15—**PAYMENTS TO CONTRACTOR, SET OFFS; COMPLETIONS; CORRECTION PERIOD**

No suggested Supplementary Conditions in this Article.

Article 16—**SUSPENSION OF WORK AND TERMINATION**

No suggested Supplementary Conditions in this Article.

Article 17—**FINAL RESOLUTIONS OF DISPUTES**

17.02 *Arbitration*

SC-17.02. Add the following new paragraph immediately after Paragraph 17.01.

SC-17.02.A. All matters subject to final resolution under this Article will be decided by arbitration in accordance with the rules of NRS, subject to the conditions and limitations of this paragraph. This agreement to arbitrate and any other agreement or consent to arbitrate entered into will be specifically enforceable under the prevailing law of any court having jurisdiction.

SC-17.02.B. The demand for arbitration will be filed in writing with the other party to the Contract and with the selected arbitrator or arbitration provider, and a copy will be sent to Engineer for information. The demand for arbitration will be made within the specific time required in this Article, or if no specified time is applicable within a reasonable time after the matter in question has arisen, and in no event shall any such demand be made after the date when institution of legal or equitable proceedings based on such matter in question would be barred by the applicable statute of limitations. The demand for arbitration should include specific reference to Paragraph SC-17.02.D below.

SC-17.02.C. No arbitration arising out of or relating to the Contract shall include by consolidation, joinder, or in any other manner any other individual or entity (including Engineer, and Engineer's consultants and the officers, directors, partners, agents, employees or consultants of any of them) who is not a party to this Contract unless:

SC-17.02.C.1. the inclusion of such other individual or entity is necessary if complete relief is to be afforded among those who are already parties to the arbitration; and

SC-17.02.C.2. such other individual or entity is substantially involved in a question of law or fact which is common to those who are already parties to the arbitration and which will arise in such proceedings.

SC-17.02.D. The award rendered by the arbitrator(s) shall be consistent with the agreement of the parties, in writing, and include a concise breakdown of the award, and a written explanation of the award specifically citing the Contract provisions deemed applicable and relied on in making the award.

SC-17.02.E. The award will be final. Judgment may be entered upon it in any court having jurisdiction thereof, and it will not be subject to modification or appeal, subject to provisions of the Laws and Regulations relating to vacating or modifying an arbitral award.

SC-17.02.F. The fees and expenses of the arbitrators and any arbitration service shall be shared equally by Owner and Contractor.

Article 18—**MISCELLANEOUS**

No suggested Supplementary Conditions in this Article.

END OF SUPPLEMENTARY CONDITIONS

STATE OF NEVADA

JOE LOMBARDO
GOVERNOR

TERRY REYNOLDS
DIRECTOR

BRETT HARRIS
LABOR COMMISSIONER



OFFICE OF THE LABOR COMMISSIONER
3340 WEST SAHARA AVENUE
LAS VEGAS, NV 89102
PHONE: (702) 486-2650
FAX (702) 486-2660
OFFICE OF THE LABOR COMMISSIONER
1818 COLLEGE PARKWAY, SUITE 102
CARSON CITY, NV 89706
PHONE: (775) 684-1890
FAX (775) 687-6409

EMAIL: PUBLICWORKS@LABOR.NV.GOV

2024 PREVAILING WAGE RATES WASHOE COUNTY

DATE OF DETERMINATION: October 1, 2023

**APPLICABLE FOR PUBLIC WORKS PROJECTS OVER \$100,000 BID/AWARDED
OCTOBER 1, 2023 THROUGH SEPTEMBER 30, 2024**

Pursuant to Nevada Revised Statutes (NRS) section 338.030(9)(a), "If the contract for a public work: (a) Is to be awarded pursuant to a competitive bidding process, the prevailing wages in effect at the time of the opening of the bids for a contract for a public work must be paid until the completion or termination of the contract or for the 36 months immediately following the date on which the bids were opened, whichever is earlier." For contracts not awarded pursuant to competitive bidding, please see NRS section 338.030(9)(b). However, if a project exceeds 36 months new wage rates may apply pursuant to NRS section 338.030(9)(10). Prevailing Wage Rates may be adjusted based on Collective Bargaining Agreements (CBA's) and adjustments to those agreements. (See NRS 338.030)

PREVAILING WAGE DETERMINATIONS - NRS 338.030 subsection 7, the wages so determined must be:

- (a) Issued by the Labor Commissioner on October 1 of the odd-numbered year in which the survey was conducted and, except as otherwise provided in subsection 8, remain effective for 2 years after that date; and
- (b) Made available by the Labor Commissioner to any public body which awards a contract for any public work.

Senate Bill 243 passed during the 80th Nevada Legislative Session (2019) and set forth in NRS section 338.025, now requires the Labor Commissioner to calculate the Prevailing Wage Rates by region. NRS section 338.025 Prevailing wage regions. For the purpose of determining the prevailing rate of wages pursuant to NRS section 338.030, four prevailing wage regions are hereby established in this State as follows:

1. The Washoe Prevailing Wage Region consisting of Washoe County;
2. The Northern Rural Prevailing Wage Region consisting of Carson City and the counties of Churchill, Douglas, Elko, Eureka, Humboldt, Lander, Lyon, Mineral, Storey, Pershing and White Pine;
3. The Clark Prevailing Wage Region consisting of Clark County; and
4. The Southern Rural Prevailing Wage Region consisting of the counties of Esmeralda, Lincoln and Nye.

OBJECTIONS TO PREVAILING WAGE DETERMINATIONS – NRS section 338.030 subsection 2. Objections to the Prevailing Wage Determinations must be submitted within 30 days after the Prevailing Wage Determinations are issued.

Pursuant to NRS section 338.030 subsection 8, the Labor Commissioner will review the prevailing wage rates in each even-numbered year to determine if adjustments should be made.

As Amendments/Revisions are made to the wage rates, they will be posted on the website for each respective Region. Please review regularly for any Amendments/Revisions that are posted or contact our offices directly for further assistance.

Air Balance Technician	4
Alarm Installer	5
Boilermaker	6
Bricklayer	7
Carpenter	8
Cement Mason	9
Electrician – Communication Technician	10
Electrician - Lineman	11
Electrician – Neon Sign	13
Electrician - Wireman	14
Elevator Constructor	15
Fence Erector	17
Flagperson	18
Floorcoverer	19
Glazier	20
Highway Striper	22
Hod Carrier-Brick Mason	23
Hod Carrier – Plasterer Tender	24
Ironworker	26
Laborer	29
Lubrication And Service Engineer (Mobile And Grease Rack)	30
Mechanical Insulator	31
Millwright	32
Operating Engineer	35
Operating Engineer – Steel Fabricator & Erector	35
Operating Engineer – Piledriver	36
Painter	38
Piledriver (Non-Equipment)	40
Plasterer	42
Plumber/Pipefitter	43
Refrigeration	44
Roofer	45
Sheet Metal Worker	46
Soils and Material Tester	47
Sprinkler Fitter	47
Surveyor	48
Taper	49
Tile/Terrazzo Worker/Marble Mason Finisher	50
Tile/Terrazzo Worker/Marble Mason	51
Traffic Barrier Erector	53
Truck Driver	54
Well Driller	56
Group Classifications	
Labor Group Classifications	57
Operating Engineers	61

NRS section 338.010 subsection (25) “Wages” means:

- a) The basic hourly rate of pay; and
- b) The amount of pension, health and welfare, vacation and holiday pay, the cost of apprenticeship training or other similar programs or other bona fide fringe benefits which are a benefit to the worker.

NRS section 338.035 Bona Fide Fringe Benefits - Discharge of part of obligation of contractor or subcontractor engaged on public work to pay wages by making certain contributions in name of workman. “Bona fide fringe benefit” means a benefit in the form of a contribution that is made not less frequently than monthly to an independent third party pursuant to a fund, plan or program: (a) Which is established for the sole and exclusive benefit of a worker and his or her family and dependents; and (b) For which none of the assets will revert to, or otherwise be credited to, any contributing employer or sponsor of the fund, plan or program. The term includes, without limitation, benefits for a worker that are determined pursuant to a collective bargaining agreement and included in the determination of the prevailing wage by the Labor Commissioner pursuant to NRS section 338.030.

Please see NRS sections 338.010, 338.020, and 338.035 and Nevada Administrative Code (NAC) sections 338.0097 and 338.092 through 338.100 for further details on “Bona fide fringe benefits” and reporting requirements and exceptions.

Job Descriptions for Recognized Classes of Workers

Regarding job descriptions for public works projects, please take notice of the following:

1. The job description links have been redacted to include ONLY the scope of work for the craft.
2. Pursuant to NAC section 338.0095(1)(a) - A worker employed on a public work must be paid the applicable prevailing rate of wage for the type of work that the worker actually performs on the public work and in accordance with the recognized class of the worker.
3. The work description for a particular class is not intended to be jurisdictional in scope.
4. Any person who believes that a type of work is not classified, or who otherwise needs clarification pertaining to the recognized classes or job descriptions, shall contact the Labor Commissioner in writing for a determination of the applicable classification and pay rate for a particular type of work.
5. The job descriptions set forth or referenced herein supersede any, and all descriptions previously agreed upon by the Labor Commissioner in any settlement agreements or stipulations arising out of contested matters.
6. The following specific provisions, where applicable, shall prevail over any general provisions of the job descriptions:
 - Amendments to the prevailing wage determinations.
 - Group Classifications and/or descriptions recognized by the Labor Commissioner and included with wage determinations for a particular type of work in a particular county.

Zone Rates

The zone rate has been added to each applicable craft.

Premium Pay Premium pay for hours worked in excess of a shift of 8 hours or 12 hours, or such other time increment set forth in the Collective Bargaining Agreement or on a weekend or holiday.

Craft: AIR BALANCE TECHNICIAN (Union Rate)

Prevailing wage rates include the base rate as well as all applicable fringes

Air Balance Technician Journeyman.....	73.87
Air Balance Technician-Foreman.....	78.26
Air Balance Technician-General Foreman.....	82.65

ADD ZONE RATE

In addition to AIR BALANCE rates add the applicable amounts per hour, calculated based on a road from the courthouse in Reno, Nevada:

Zone 1	0 to 75 miles	\$0.00
Zone 2	75 to 100 miles	\$5.00
Zone 3	Over 100 miles	\$10.00 the employee shall be provided reasonable lodging and meal expenses.

ADD PREMIUM PAY

All hourly rates are subject to Over Time (One and one half 1 ½) of the Regular rate:

1. For all hours worked over Eight (8) Hours in one day or shift.
2. For the first Eight (8) Hours work on Saturday.

All hourly rates are subject to Double Time of the Regular Rate:

1. For all hours worked over Ten (10) Hours in one day or shift.
2. For all hours worked over Eight (8) Hours on Saturday.
3. For all hours worked on Sunday, New Year’s Day, President’s Day, Memorial Day, Independence Day, Labor Day, Nevada Day, Thanksgiving Day, Day after Thanksgiving, Day before Christmas, and Christmas Day.

RECOGNIZED HOLIDAYS

New Year’s Day, President’s Day, Memorial Day, Independence Day, Labor Day, Nevada Day, Thanksgiving Day, Day after Thanksgiving, Day before Christmas, and Christmas Day

JOB DESCRIPTION: Excerpt from Sheet Metal Local 26 Collective Bargaining Agreement

(a) manufacture, fabrication, assembling, handling, erection, installation, dismantling, conditioning, adjustment, alteration, repairing and servicing of all ferrous or nonferrous metal work and all other materials used in lieu thereof and of all HVAC systems, air veyor systems, exhaust systems, and air-handling systems regardless of material used including the setting of all equipment and all reinforcements in connection therewith; (b) all lagging over insulation and all duct lining; (c) testing and balancing of all air-handling equipment and duct work; (d) the preparation of all shop and field sketches whether manually drawn or computer assisted used in fabrication and erection, including those taken from original architectural and engineering drawings or sketches; (e) metal roofing; and (f) all other work included in the jurisdictional claims of International Association of Sheet Metal, Air, Rail and Transportation Workers.

Craft: ALARM INSTALLER (Non-Union Rate)

Prevailing wage rates include the base rate as well as all applicable fringes

Alarm Installer.....39.90

JOB DESCRIPTION:

Includes but is not limited to:

1. Installing or testing electrical protective signaling systems used to provide notification of fire, burglary or other irregularities on the premises of the subscriber of the system;
2. Installing of wiring and signaling units;
3. Repairing electrical protective signaling systems
4. Starting up, programming and documenting systems;

Craft: BOILERMAKER (Union Rate)
Prevailing wage rates include the base rate as well as all applicable fringes

Boilermaker.....	72.01
Boilermaker Foreman.....	74.51

ADD PREMIUM PAY

Premium pay for hours worked in excess of a shift of 8 hours or 12 hours or such other time increment set forth in the Collective Bargaining Agreement or on a weekend or holiday.

PER DIEM payments and TRAVEL pay shall be paid as follows:

The Contractor shall pay the employee Per Diem in the amount of seventy-five dollars (\$75 .00) per day worked where the job site is 70 miles or more but less than 120 miles from the dispatch point.

For mileage of 120 miles or more, the daily Per Diem amount shall be ninety dollars (\$90.00) per day worked.

Where the job site is over 120 miles or more from the dispatch point, employees shall receive the I.R.S. maximum allowable per mile for transportation between the dispatch point and the job site at the beginning and conclusion of their employment.

Where a job is located two hundred and forty (240) miles or more from the dispatch point, the employee will receive one additional day's Per Diem at the beginning of employment and one additional day's Per Diem at the conclusion of employment.

JOB DESCRIPTION:

Includes but is not limited to:

1. Constructing, assembling, maintaining and repairing stationary steam boilers and boiler house auxiliaries;
2. Aligning structures or plate sections to assemble boiler frame tanks or vats;
3. Assisting in the testing of assembled vessels, directing cleaning of boilers and boiler furnaces;
4. Inspecting and repairing boiler fittings, including, without limitation, safety valves, regulators, automatic-control mechanisms, water columns and auxiliary machines.

Craft: BRICKLAYER (Union Rate)
Prevailing wage rates include the base rate as well as all applicable fringes

Bricklayer Journeyman.....51.71
 Bricklayer Foreman.....52.96

ADD ZONE PAY in addition to BRICKLAYER rates add the applicable amounts per hour, calculated based on road miles of over thirty-five (35) miles from the Washoe County Courthouse in Reno, Nevada:

Zone 1	0 to 35 miles	\$0.00
Zone 2	35 to 75 miles	\$2.50
Zone 3	Over 75 miles	\$8.12

ADD PREMIUM PAY

One and one half (1 ½) the regular straight time hourly rate shall be paid:

1. For all hours worked over eight (8) hours in one day or shift.
2. For any hours worked on Saturday from midnight to midnight.

Double the regular straight time hourly rate shall be paid for all time:

1. For all hours worked over twelve (12) hours in one day or shift.
2. For any hours worked on Sunday from midnight to midnight.
3. For any hours worked on holidays from midnight to midnight.

RECOGNIZED HOLIDAYS

If any of these holidays fall on Sunday, the Monday following shall be considered a Holiday. New Year's Day, President's Day, Memorial Day, Fourth of July, Labor Day, Admission Day, Thanksgiving Day, Day after Thanksgiving Day, Christmas Day.

JOB DESCRIPTION: Excerpt from Agreement between No, NV Masonry Contractors and LIUNA Local 169

This shall apply to and cover the work of Brick/Block Masonry, Stone Masonry, Artificial Masonry Marble Masonry.

Craft: CARPENTER (Union Rate)

Prevailing wage rates include the base rate as well as all applicable fringes

Carpenter Journeyman.....	58.42
Carpenter Foreman.....	62.06
Carpenter General Foreman.....	66.06

ADD ZONE RATE

(Building and Heavy Highway and Dam Construction)

In addition to CARPENTER rates add the applicable amounts per hour, calculated from the Washoe County Courthouse:

Zone 1	Within 75 road miles	\$0.00
Zone 2	Between 75 to 150 road miles	\$6.00
Zone 3	Between 150 to 300 road miles	\$7.00
Zone 4	In excess of 300 road miles	\$8.00

ADD PREMIUM PAY

Any work performed over eight (8) hours per day and on Saturdays shall be compensated at time and one-half (1-1/2x) the appropriate hourly rate. All work performed on Sundays, holidays and over twelve (12) hours in one (1) day shall be compensated at two times (2x) the appropriate hourly rate. In the event a day's work is lost because of severe weather conditions or major mechanical breakdown, work may be performed on a voluntary basis on a Saturday at the straight time hourly rate for eight (8) hours provided the straight time hours worked in one (1) week do not exceed forty (40) hours.

RECOGNIZED HOLIDAYS

New Year's Day, Memorial Day, 4th of July, Labor Day, Admission's Day, Thanksgiving Day, the Friday after Thanksgiving, Christmas Day.

JOB DESCRIPTION Excerpt from Southwest Regional Council of Carpenters and Affiliated Local Unions Master Labor Agreement

(1) All building construction, including but not limited to the construction, erection, alteration, repair, modification, demolition, addition, or improvement in whole or in part of any building structure. All rigging of Carpenters', and Piledrivers' materials.

(2) All heavy, highway and engineering construction, including but not limited to the construction, improvement, modification and demolition of all or any part of the streets, highways, bridges, viaducts, railroads, tunnels, airports, water supply, irrigation, flood control and draining systems, sewers and sanitation projects, dams, power houses, refineries, aqueducts, canals, river and harbor projects, wharves, docks, breakwaters, jetties, quarrying of breakwaters or rip rap stone or operations incidental to such heavy construction work and whether such work is above or below the water line level.

(3) The character of such work covered by this Agreement shall include but not be limited to all carpenter, concrete form work, shoring, drywall, metal stud, drywall finishing, plaster, scaffold, modular furniture, trade show work, insulation, acoustical, and lathing work on such construction, including but not limited to plastics and such work in connection with new methods of construction or use of materials.

(4) All interior and/or exterior wall finish work, including EIFS and other wet wall finish work.

Craft: CEMENT MASON (Union Rate)

Prevailing wage rates include the base rate as well as all applicable fringes

Cement Mason - Journeyman.....	51.92
Cement Mason - Foreman.....	55.55

ADD ZONE RATE

In addition to CEMENT MASON rates add the applicable amounts per hour, calculated from the Washoe County Courthouse:

Zone 1	0 to 75 miles	\$0.00
Zone 2	75 to 150 miles	\$6.00
Zone 3	150 to 300 miles	\$7.00
Zone 4	More than 300 miles	\$8.00

ADD PREMIUM PAY

OVERTIME – Any worked performed over eight (8) hours per day shall be compensated at time and one half the hourly rate. All work performed after twelve (12) consecutive hours shall be paid at double the hourly rate. All worked performed on Saturdays shall be compensated at time and one half the hourly rate. All Sunday and Holiday work shall be paid for at double time.

RECOGNIZED HOLIDAYS

New Year’s Day, Memorial Day, Independence Day, Labor Day, Admissions Day, Thanksgiving Day and the following Friday following Thanksgiving Day, and Christmas

JOB DESCRIPTIONS

1. All building construction, including but not limited to the construction, erection, alteration, repair, modification, demolition, addition, or improvement in whole or in part of any building structure.
2. All heavy, highway and engineering construction, including but not limited to construction, improvement, modification, demolition, of all or any part of streets and highways (including sidewalks, curbs and gutters), bridges, viaducts, rail roads, tunnels, airports, water supply, irrigation, flood control and drainage systems, sewers and sanitation projects, dams, power houses, refineries, aqueducts, canals, river and harbor projects, wharves, docks, breakwaters, jetties, quarrying of breakwater or rip-rap stone, or operation incidental to such heavy construction work.
3. The work to be performed by Cement Masons shall include but not be limited to the following, when tools of the Cement Masons trade are used or required:
 Setting screeds, screed pins, curb forms and curb and gutter forms, rodding, spreading and tamping concrete, hand application of curing compounds, applying topping (wet or dry) colors or grits; using Darby and push floats, hand troweling or hand floating; marking edging, brooming or brushing, using base cove or step tools; chipping, and stoning, patching or sacking; dry packing; spreading and finishing gypsum, operating mechanical finishers (concrete) such as Clary, Jackson, Bidwell Bridge Deck Paver or similar types; grinding machines; troweling machines, floating machines powered concrete saws; finishing of epoxy and resin materials, bush hammering and exposed finishes for architectural work.
 Operation of skill saw, chain saw, Laser Screed, Laser Level, Curb and Slipform machines, Epoxy Type Injection pumps, stamps or other means of texturing, any new devices, which are beneficial to the construction of or with concrete or related products.

Craft: ELECTRICIAN COMMUNICATION TECHNICIAN (Non-Union Rate)

Prevailing wage rates include the base rate as well as all applicable fringes

Communication Technician.....41.13

JOB DESCRIPTION:

ELECTRONIC COMMUNICATION TECHNICIAN, includes but is not limited to:

1. Pulling cable, installing and trimming devices, terminating loops, circuits, or other data gathering points;
2. Termination of main control panels, racks, or other head end equipment, as well as testing of all circuits from the field devices to the main control panels and/or equipment; 2016-2017 Prevailing Wage Rates – Washoe County 13
3. Utilizing test equipment for the purpose of troubleshooting and verifying the integrity of the circuits in question;
4. Using hand tools to assemble and install data communication lines and equipment computer systems, antennas and towers;
5. Disassembling equipment to adjust, repair or replace parts using hand tools;
6. Starting up, programming and documenting systems;
7. Measuring, cutting, splicing, connecting, soldering and installing wire and cable associated with communication systems.

Craft: ELECTRICIAN LINEMAN/GROUNDMAN/HEAVY EQUIPMENT OPERATOR
(Union Rate)

Prevailing wage rates include the base rate as well as all applicable fringes

Electrician-Groundman.....	39.57
Lineman-Journeyman.....	67.30
Lineman-Foreman.....	73.99
Lineman-General Foreman.....	80.76
Lineman-Equipment Man.....	51.75

ADD PREMIUM PAY

Premium pay for hours worked in excess of a shift of 8 hours or 12 hours or such other time increment set forth in the Collective Bargaining Agreement or on a weekend or holiday.

RECOGNIZED HOLIDAYS

New Year's Day, President's Day, Memorial Day, Fourth of July, Labor Day, Nevada Day, Thanksgiving Day and the Friday following, Christmas Day.

JOB DESCRIPTION:

Outside, overhead and underground construction and maintenance work on electrical transmission lines, switch yards, substations and distribution systems which shall include:

1. Pole line work (whether built of wood, metal or other material): the digging and back-filling of holes for poles or anchors (by hand or mechanical equipment): the loading or unloading, handling, sorting and moving of materials; the assembly or erection of all materials including the guying, stringing of conductors and fiber optics or other work necessary on through to the ultimate completion of such pole work.
2. Steel or metal structures used for the purpose of carrying electrical wire, conductors, or equipment (this includes transmission towers, outdoor substations, switch racks, or similar electrical structures); the moving of men, tools or equipment; the loading or unloading, handling, sorting and moving of materials; the assembly and erection of all materials used on the job site, including the assembly of the grillage and foundations, on through to the ultimate completion of such structures. Work covered shall include the grounding of all such structures except the bonding of stub-angle to rebar cage; the stringing and installation of wires, cables and insulators or other electrical equipment suspended from structure; also the handling and placing of transformers or O.C.B.'s and other related electrical equipment.

The moving of men, tools or equipment; the loading or unloading, handling, sorting and moving of materials; the assembly of all electrical materials on race-ways such as ducts, shall be performed by workmen under the Agreement. This shall also include CIC (cable in conduit), CC (coilable conduit), the placing of fish wire, the pulling of cables or wires through such race-ways, installing and making up of termination and the splicing of such conductors.

Street lighting systems where such work properly comes under the outside jurisdiction shall be handled in the same manner as pole line construction.

Installing and maintaining the catenary and trolley work and bonding of rails shall be handled in the same manner as pole line, and steel construction.

In connection with all of the above items, it is understood the scope of this Agreement shall include not only new installation work but shall also govern the repair, maintenance or dismantling of such structures, lines or equipment; the handling and operating of all equipment used to transport men, tools and/or materials on

the job site as well as the equipment used to move, raise or place materials used in the Outside Branch of the Electrical Industry shall be performed by workmen under this Agreement unless otherwise excluded herein.

Craft: ELECTRICIAN – NEON SIGN (Union Rate)

Prevailing wage rates include the base rate as well as all applicable fringes

Electrician Neon Sign Journeyman.....	63.15
Electrician Neon Sign Foreman.....	65.15
Electrician Neon Sign Truck Foreman supervising (4) or more.....	67.65

ADD PREMIUM PAY

One and one half (1 ½X) the regular straight time hourly rate shall be paid:

1. For all hours worked over eight (8) hours in one day or shift, either before or after the shift.
2. For up to 8 hours worked on Saturday from midnight to midnight.

Double (2X) the regular straight time hourly rate shall be paid for all time:

1. For all hours worked over eleven (11) hours in one day or shift, Monday thru Friday.
2. For all hours worked in excess of 8 hours on Saturday, Sundays or Holidays.

SHIFT DIFFERENTIAL

Second Shift (Swing) will be an additional \$1.25 cents per hour.

Third Shift (Graveyard) will be an additional \$1.50 per hour.

HIGH TIME (Working at heights)

1. All employees working at height of 65 feet and subject to a direct fall shall be paid an additional \$2.75 per hour in addition to their normal rate for a minimum of 2 hours.
2. All employees working at height of 125 feet or when repelling below 65 feet shall be paid an additional \$4.00 per hour in addition to their normal rate for a minimum of 4 hours.

FOREMAN/TRUCK FOREMAN

1. First employee on the job (TRUCK FOREMAN) must have a CDL and Welder certification and shall be paid \$2.00 per hour in addition to their normal rate of pay.

2. When the first employee on the job (FOREMAN) is supervising (4) or more workers, he or she shall be paid an additional \$2.50 per hour. In addition to their normal rate of pay.

3. When the first employee on the job (TRUCK FOREMAN and FOREMAN) has a CDL and Welder certification and is supervising (4) or more workers, he or she shall be paid an additional \$4.50 per hour. In addition to their normal rate of pay.

RECOGNIZED HOLIDAYS

New Year’s Day, Martin Luther King Day, President’s Day unpaid holiday; double time for any hours worked, Memorial Day, Independence Day, Labor Day, Veteran’s Day, Thanksgiving Day, Day after Thanksgiving Day, Christmas Eve ½ day (4 hours) unpaid holiday; straight time for first four hours worked and double time for hours worked after four hours, Christmas Day.

JOB DESCRIPTION Includes but is not limited to:

1. Installing, servicing and repairing plastic, neon and illuminated signs.
2. Ascending ladders or operating hydraulic or electric hoist to install, service, or examine sign to determine cause of malfunction.
3. Wiring, rewiring or removing defective parts and installing new parts using electrician's tools.
4. Removing sign or part of sign for repairs, such as structural fabrication, scroll repair, or transformer repair.

Craft: ELECTRICIAN WIREMAN (Union Rate)

Prevailing wage rates include the base rate as well as all applicable fringes

Wireman.....	69.61
Wireman-Cable Splicer.....	75.41
Wireman Forman.....	75.41
Wireman General Foreman.....	81.21

ADD ZONE RATE

In addition to ELECTRICIAN-Wireman, rates, add the applicable amounts per hour, calculated from Washoe County Courthouse, Reno Nevada:

Zone 1	0 to 70 miles	\$0.00
Zone 2	70 to 90 miles	\$8.00
Zone 3	90 miles and over	\$10.00

ADD PREMIUM PAY

Premium pay for hours worked in excess of a shift of 8 hours or 12 hours or such other time increment One and one half (1 ½) the regular straight time hourly rate shall be paid:

1. For all hours worked over eight (8) hours in one day or shift.
2. For the first eight (8) hours worked on Saturday

Double the regular straight time hourly rate shall be paid for all time:

3. For all hours worked over ten (10) hours in one day or shift.
4. For any hours worked on Sunday
5. For any hours worked on Holidays

Shift Rates

1. Swing shift to be paid at seventeen-point three (17.3) percent the regular straight time rate for hours between 4:30 p.m. and 1:00 a.m.
2. Graveyard shift to be paid at thirty-one-point four (31.4) percent the regular straight time rate for hours between 12:30 a.m. and 9:00 a.m.
3. Shifts are established for at least five (5) consecutive days or double the regular straight time rate shall be paid.

**Note – Double the straight time rate is the max rate paid. (No pyramiding of overtime rates)

RECOGNIZED HOLIDAYS

New Year’s Day, Memorial Day, Independence Day, Labor Day, Admission Day, Veteran’s Day, Thanksgiving Day, Friday following Thanksgiving Day, Christmas Day.

JOB DESCRIPTION: Excerpt from Agreement between NECA and Local Union 401, IBEW

All electrical construction, installation, or erection work including fabrication or prefabrication of boxes, brackets, bends and nipples and all electrical maintenance thereon including the final running tests. This shall include the installation and maintenance of temporary wiring and the installation of all electrical lighting, heat and power equipment, installation of all raceway systems, including underground conduits and all supports, underground utility conduits, photovoltaic power generation systems, wind power generation systems and geothermal power generating systems. Further all salvage of electrical work shall be included.

Craft: ELEVATOR CONSTRUCTOR (Union Rate)

Prevailing wage rates include the base rate as well as all applicable fringes

Elevator Constructor-Journeyman Mechanic.....	122.16
Elevator Constructor-Journeyman Mechanic In Charge.....	132.63

ADD PREMIUM PAY

Work performed on Construction Work on Saturdays, Sundays and before and after 30 the regular working day on Monday to Friday, inclusive, shall be classed as overtime, and paid for at double the rate of single time.

RECOGNIZED HOLIDAYS

New Year's Day, Memorial Day, Independence Day, Labor Day, Nevada Day, Veteran's Day, Thanksgiving Day, Day after Thanksgiving Day, Christmas Day.

JOB DESCRIPTION: Excerpt from Agreement of International Union of Elevator Constructors

The handling and unloading of all equipment coming under the jurisdiction of the Elevator Constructor, from the time such equipment arrives at or near the building site, shall be handled and unloaded by the Elevator Constructors. Mechanical equipment such as a forklift or truck mounted swing boom may be used by the Elevator Constructors. A derrick, crane or material hoist can be used under the supervision of Elevator Constructors to handle and unload the heavy material described in

Par. 5(a). Where unusual conditions are expected to exist prior to delivery of equipment at or near the building site in regard to handling and unloading of equipment in the primary or secondary jurisdiction of the local union, the Company shall contact the Local's Business Representative to make appropriate arrangements for the handling and unloading of such equipment. In areas outside the jurisdiction of the local union, the Company shall contact the Regional Director.

(b) The erecting and assembling of all elevator equipment to wit: electric, hydraulic, steam, belt, dumbwaiters, residence elevators, parking garage elevators (such as Bowser, Pigeon Hole, or similar types of elevators), shuttles, compressed air and handpower, automatic people movers, monorails, airport shuttles and like-named devices used in the transportation of people for short distances of travel (less than 5 miles), as well as vertical reciprocating conveyor systems.

(c) It is understood and agreed that the preassembly of all escalators, moving stairways and link belt carriers that may be done in the factory shall include the following:

1. Truss or truss sections with tracks, drive units, machines, handrail drive sheaves, drive chains, skirts on the incline sections but not curved sections, step chains and steps installed and permanently aligned.
2. Balustrade brackets may be shipped attached but not aligned.
3. Setting of all controllers and all wiring and conduit from the controller.

All other work on escalators, moving stairways and link belt carriers shall be performed in the field before or after the truss or truss sections are joined and/or hoisted and placed in permanent position. This includes any and all work not done in the factory. The erecting and assembly of all theater stage and curtain elevator equipment and guides and rigging thereto, organ consoles and orchestra elevators

- (d) All wiring, conduit, and raceways from main line feeder terminals on the controller to other elevator apparatus and operating circuits. Controllers are not to be shipped from the factory with extended wiring attached thereto.
- (e) The erecting of all guide rails.
- (f) The installation of all grating under the control of the Company. The installation of all counterweight screens, overhead work, either wood or iron, and all material used for mounting of elevator apparatus in machine room, overhead or below.
- (g) The drilling of overhead beams for attaching machines, sheaves, kick angles, and all other elevator equipment.
- (h) The setting of all templates.
- (i) All foundations, either of wood or metal, that should take the place of masonry.
- (j) The assembly of all cabs complete.
- (k) The installation of all indicators.
- (l) The erecting of all electrical or mechanical automatic or semi-automatic gates complete.
- (m) The hanging of all automatic or semi-automatic elevator hoistway doors, together with the installation of hangers and tracks.
- (n) The installation of all devices for opening and closing and locking of elevator car and hoistway doors and gates.
- (o) The drilling of doors for mounting of closing devices.
- (p) The drilling of angle supports for mounting of closing devices except one template hole.
- (q) The drilling of sills for sill trips.
- (r) The operating of temporary cars.
- (s) The setting of all elevator pressure open or pit tanks.
- (t) The setting of hydraulic power units (power units include: motor, pump, drive valve system, internal piping, muffler, internal wiring, controller and tank). Where power units arrive in parts, they shall be assembled at the job site. The wiring and piping to and between multiple hydraulic power units shall be performed at the job site.
- (u) All air cushions with the exception of those built of brick or those put together with hot rivets.
- (v) Landing door entrances.

Craft: FENCE ERECTOR (Union Rate)

Prevailing wage rates include the base rate as well as all applicable fringes

Fence Erector.....48.78

ADD ZONE RATE

In addition to FENCE ERECTOR rates add the applicable amounts per hour, calculated based on a road miles from either the Carson City Courthouse or the Washoe County Courthouse:

Zone 1	0 to 75 miles	\$0.00
Zone 2	75 to 150 miles	\$6.00
Zone 3	150 to 300 miles	\$7.00
Zone 4	300 miles or over	\$8.00

ADD PREMIUM PAY

One and one half (1 ½) the regular straight time hourly rate shall be paid:

1. For all hours worked over eight (8) hours in one day or shift.
2. For any hours worked on Saturday from mid night to midnight.

Double the regular straight time hourly rate shall be paid for all time:

1. For all hours worked over twelve (12) hours in one day or shift.
2. For any hours worked on Sunday from midnight to midnight.
3. For any hours worked on holidays from midnight to midnight.

RECOGNIZED HOLIDAYS

If any of these holidays fall on Sunday, the Monday following shall be considered a Holiday. New Year’s Day, President’s Day, Memorial Day, Fourth of July, Labor Day, Admission Day, Thanksgiving Day, Day after Thanksgiving Day, Christmas Day.

JOB DESCRIPTION:

Includes but is not limited to:

1. Erecting or repairing chain link, wooden, tortoise, wire/wire mesh, or temporary fencing;
2. Mixing and pouring concrete around bases of posts and tamping soil into post hole to embed post;
3. Digging post holes with a spade, post hole digger or power-driven auger;
4. Aligning posts through the use of lines or by sighting;
5. Verifying vertical alignment of posts with a plumb bob or spirit level.

Craft: FLAG PERSON (Union Rate)

Prevailing wage rates include the base rate as well as all applicable fringes

Flag Person.....46.66

ADD ZONE RATE

In addition to FLAG PERSON add the applicable amounts per hour, calculated based on a road miles from either the Carson City Courthouse or the Washoe County Courthouse:

Zone 1	0 to 75 miles	\$0.00
Zone 2	75 to 150 miles	\$6.00
Zone 3	150 to 300 miles	\$7.00
Zone 4	300 miles or over	\$8.00

ADD PREMIUM PAY

One and one half (1 ½) the regular straight time hourly rate shall be paid:

1. For all hours worked over eight (8) hours in one day or shift.
2. For any hours worked on Saturday from midnight to midnight.

Double the regular straight time hourly rate shall be paid for all time:

1. For all hours worked over twelve (12) hours in one day or shift.
2. For any hours worked on Sunday from midnight to midnight.
3. For any hours worked on holidays from midnight to midnight.

RECOGNIZED HOLIDAYS

If any of these holidays fall on Sunday, the Monday following shall be considered a Holiday. New Year’s Day, President’s Day, Memorial Day, Fourth of July, Labor Day, Admission Day, Thanksgiving Day, Day after Thanksgiving Day, Christmas Day.

JOB DESCRIPTION

FLAG PERSON, includes but is not limited to:

1. Directing movement of vehicular traffic through construction projects;
2. Distributing traffic control signs and markers along site in designated pattern;
3. Informing drivers of detour routes through construction sites;

Craft: FLOOR COVERER (Union Rate)

Prevailing wage rates include the base rate as well as all applicable fringes

Floor Coverer Journeyman.....	57.40
Floor Coverer Foreman.....	61.14

ADD PREMIUM PAY

Any work performed over eight (8) hours per day and on Saturdays shall be compensated at time and one-half (1-1/2x) the appropriate hourly rate. All work performed on Sundays, holidays and over twelve (12) hours in one (1) day shall be compensated at two times (2x) the appropriate hourly rate. In the event a day's work is lost because of severe weather conditions or major mechanical breakdown, work may be performed on a voluntary basis on a Saturday at the straight time hourly rate for eight (8) hours provided the straight time hours worked in one (1) week do not exceed forty (40) hours.

RECOGNIZED HOLIDAYS

New Year's Day, Memorial Day, Independence Day, Labor Day, Admissions Day, Thanksgiving Day, Day after Thanksgiving Day, Christmas Day.

JOB DESCRIPTION: Excerpt from Southwest Mountain States Regional Council of Carpenters.

All work in connection with the installation of floor coverings (with the exception of wood floors which are covered by the Master Labor Agreement) such as measuring, cutting, installing, or removal and other preparation for installation of all types of floor covering. All types of floor covering regardless of material (except wood flooring), including but not limited to all types of carpeting, linoleum, vinyl, cork, laminate floors; glue down wood floor applications; rubber, cork, asphalt, linoleum or other types of tile; artificial turf and sports surfaces; any type of resilient flooring such as epoxy, polyurethane or similar materials regardless of how applied; and ceramic tile and stone. Included in the work covered is the application or installation of any type of moisture barrier and any type of underlayment or subfloor in connection with a flooring installation.

Craft: GLAZIER (Union Rate)

Prevailing wage rates include the base rate as well as all applicable fringes

Glazier Journeyman.....	33.70
Glazier Foreman.....	36.15
Glazier Superintendent.....	37.37

ADD PREMIUM PAY

One and one half (1 ½) the regular straight time hourly rate shall be paid:

1. For first two (2) hours worked over eight (8) on a regular five (5) day week.
2. For all hours worked on Saturday. Employees shall not work less than four (4) hours.

Double the regular straight time hourly rate shall be paid for all time:

1. For all hours worked beyond ten (10) hours shall be paid at two (2 X) times the straight time rate.
2. For all hours worked on Saturday beyond 8 hours (2 X) times the straight time rate.
3. For hours worked Sunday and Recognized Holidays. Employees shall not be employed for less than four (4) hours.

*Also, if there is less than 10 hours between shifts, the 2nd shift becomes an extension of the 1st shift.

*Shift Differential: To be paid for all work performed between the hours of 5:30 pm to 5 am and it will be compensated at 10% differential for all hours worked including overtime. Overtime that falls between these hours will still be paid at the appropriate overtime rate.

20.1 High Pay – work that is thirty (30) or more feet in height above grade on an elevated, mechanically operated platform (including but not limited to: swing stage, boatswain chair, crane basket, heck lift, boom lift), rappelling work, work at slab edge outside the perimeter safety cable or work at slab edge inside the perimeter safety cable if the work being performed puts the employee in a free fall situation because the perimeter safety cable is no longer at or near waist level shall be paid at the rate of one dollar (\$1.00) per hour above the straight time rate for actual hours worked. High time shall be paid in addition to all other premiums involved.

25.2 Foremen:

a) The selection of the individual to act as foreman shall be at the discretion of the Employer. On outside jobs lasting three (3) days or more and which four (4) workers or more are employed, one (1) foreman will be designated and he shall be paid ten percent (10%) per hour over the highest journeyman Glazier supervised. Inside foreman shall receive ten percent (10%) per hour above the journeyman’s wage scale.

b) When a glazier is requested to perform welding on the job site, he/she will be compensated one dollar (\$1.00) over his regular rate of pay. All equipment, including hoods, leather and gloves, will be supplied by the Employer.

RECOGNIZED HOLIDAYS

New Year’s Day, President’s Day, Memorial Day, Independence Day, Labor Day, Veteran’s Day, Thanksgiving Day, Day after Thanksgiving Day, Christmas Day.

JOB DESCRIPTION: Excerpt from Agreement between DC 16 and Glazing Contractors Associations of NV and Independent Contractors

General Glazing shall include the layout and setting by hand or with machines, cutting, preparing handling or removal of the following and incidental and supplemental to such work: setter of art glass, prism glass, beveled glass, leaded glass, automobile glass, window glass, mirrors of all types, wire glass, ribbed glass, ground glass, colored glass, figured glass, vitrolite glass, carrara glass, and all other types of opaque glass; glass chalk boards, structural glass, tempered and laminated glass, thiokal, neoprene and all other types of glass cements, all types of insulating glass units, solar heat collectors containing glass or glass substitutes, glass hand rail, electric glass, bathroom fixtures, all plastics when used in place of glass, all other similar materials when used in place of moldings, tubber, lead and all types of mastic in wood, iron, aluminum or sheet metal, sash skylights, doors, frames, stone, wall cases, show cases, books cases, sideboards, partitions, automatic doors, automatic sliding doors, revolving doors, luminous ceilings, gaskets, and plastic mirrors, the installation of the above materials, temporary or permanent, on or for any building in the course of repair, remodel, construction or alteration.

The installation of all glass framing or support systems for the same such as extruded, rolled or fabricated metals or any materials that replace the same, such as plastics, metal tubes, mullions, metal facing materials, muttins, facia trim moldings, porcelain panels, skylights, showcase doors and relative materials, including those in any or all of the buildings related to the store front and window wall, curtain wall, stop wall, skylight and dome construction. Glazing and installation of door and window frames, such as patio sliding or fixed doors, vented or fixed windows, shower doors, bath tub enclosures, screens storm stash where the glass becomes an integral part of the finished products, the tinting and coating of glass for the reflecting of heat and light, showcase tops, glass shelving of all types and table tops. In addition, such caulking, glass to glass, glass to metal, metal to concrete and panel to panels.

Production, maintenance, including all incidental and supplemental to, but not limited to Employees, and Employees who are engages int eh cutting, preparing, handling and selecting of glass and /or mirror, bevellers, silverers, blockers, scratch polishers, sand-blasters, flat glass wheel cutters, miters cutters, engraver, hole-drilling machine operations, belt sanding, automatic beveling, multi-grove edging machines, semi- and automatic-cutting machines, grinding, polishing unpacking ad racking or glass, glass packing, glass and mirror cleaning, mirror stripping, all operations in the manufacturing, framing and fabrication and assembling of all insulating units, assembling of all glass insulated solar heat collectors containing glass or glass substitutes, molding or mirrors, manufactured and assembly of sliding glass or mirror doors, the operating of all machines and equipment for these operations, oven operations, glass hangers, glass benders and operators, safety glass fabricators, inspectors, janitors, maintenance mechanics, loading and unloading or truck and railroad cars.

Craft: Highway Striper (Union Rate)

Prevailing wage rates include the base rate as well as all applicable fringes

Highway Striper.....	51.28
Highway Striper Foreman.....	51.78

ADD ZONE RATE

In addition to HIGHWAY STRIPER rates add the applicable amounts per hour, calculated based on a road miles from either the Carson City Courthouse or the Washoe County Courthouse:

Zone 1	0 to 75 miles	\$0.00
Zone 2	75 to 150 miles	\$5.00
Zone 3	150 to 300 miles	\$6.00
Zone 4	300 miles or over	\$7.00

ADD PREMIUM PAY

One and one half (1 ½) the regular straight time hourly rate shall be paid:

1. For all hours worked over eight (8) hours in one day or shift.
2. For any hours worked on Saturday from midn ight to midnight.

Double the regular straight time hourly rate shall be paid for all time:

1. For all hours worked over twelve (12) hours in one day or shift.
2. For any hours worked on Sunday from midnight to midnight.
3. For any hours worked on holidays from midnight to midnight.

RECOGNIZED HOLIDAYS

If any of these holidays fall on Sunday, the Monday following shall be considered a Holiday.

New Year’s Day, Memorial Day, 4th of July, Labor Day, Admission Day, Thanksgiving Day, Day after Thanksgiving Day, Christmas Day.

JOB DESCRIPTION:

Includes but is not limited to:

1. Painting highways, streets and parking surfaces by using manually propelled or mechanically propelled machines, brushes, rollers or spray guns;
2. Installing any device or application of any material used in lieu of paint for traffic direction, including, without limitation, buttons, tapes, plastics, rumble bars and other similar materials;

Craft: Hod Carrier-Brick Mason Tender (Union Rate)

Prevailing wage rates include the base rate as well as all applicable fringes

Brick Mason Journeyman.....	49.03
Brick Mason Foreman.....	49.43

ADD ZONE RATE

In addition to Hod Carrier Brick Mason Tender rates add the applicable amounts per hour, calculated based on road miles from either the Carson City Courthouse or the Washoe County Courthouse:

Zone Rate	75 miles and over	\$8.13
-----------	-------------------	--------

ADD PREMIUM PAY

One and one half (1 ½) the regular straight time hourly rate shall be paid:

1. For all hours worked over eight (8) hours in one day or shift.
2. For any hours worked on Saturday from midnight to midnight.

Double the regular straight time hourly rate shall be paid for all time:

1. For all hours worked over twelve (12) hours in one day or shift.
2. For any hours worked on Sunday from midnight to midnight.
3. For any hours worked on holidays from midnight to midnight.

RECOGNIZED HOLIDAYS

If any of these holidays fall on Sunday, the Monday following shall be considered a Holiday.

New Year's Day, President's Day, Memorial Day, Fourth of July, Labor Day, Admission Day, Thanksgiving Day, Day after Thanksgiving Day, Christmas Day.

JOB DESCRIPTION: Excerpt from Agreement between No, NV Masonry Contractors and LIUNA Local 169

Conveying of all materials used by the Brick and Stone Masons from the first point of delivery to the Mechanic whether done manually or by a piece of machinery or equipment devised to replace the wheelbarrow or buggy, including but not limited to the forklift. The handling of Bricks, Blocks, mortar, or any other material to serve the bricklayer in any capacity building and dismantling scaffolds of any kind or type used by Bricklayers for masonry work including but not limited to tower scaffolds, access scaffolds, or other specialty scaffolds, mixing and tempering mortar by hand and/or machine, mixing grout and cleaning up after the bricklayer, the repairing and maintenance of all equipment, either on the job or in the yard.

Craft: Hod Carrier-Plasterer Tender (Union Rate)

Prevailing wage rates include the base rate as well as all applicable fringes

Plasterer Tender-Journeyman.....	49.37
Plasterer Tender- Gun Tender.....	50.37
Plasterer Tender-Foreman.....	50.73

ADD ZONE RATE

In addition to: HOD CARRIER-PLASTERER TENDER rates add the applicable amounts per hour, calculated based on road miles from either the Carson City Courthouse or the Washoe County Courthouse:

Zone Rate	75 miles and over	\$8.00
-----------	-------------------	--------

ADD PREMIUM PAY

One and one half (1 ½) the regular straight time hourly rate shall be paid:

1. For all hours worked over eight (8) hours in one day or shift.
2. For any hours worked on Saturday from mid night to midnight.

Double the regular straight time hourly rate shall be paid for all time:

1. For all hours worked over twelve (12) hours in one day or shift.
2. For any hours worked on Sunday from midnight to midnight.
3. For any hours worked on holidays from midnight to midnight.

RECOGNIZED HOLIDAYS

If any of these holidays fall on Sunday, the Monday following shall be considered a Holiday. New Year's Day, President's Day, Memorial Day, Fourth of July, Labor Day, Admission Day, Thanksgiving Day, Day after Thanksgiving Day, Christmas Day.

JOB DESCRIPTION: Excerpt from Agreement between Plasterers Contractors and LIUNA Local Union 169

Any Employee within the scope of this division tending or serving any other worker performing plasterers work, any plasterer, plasterers, or apprentices in any capacity performing plasterers work including but not limited to, handling and conveying of all materials after delivery used by plasters, including but not limited to, inside finish coat, outside finish coat, brown coat, scratch coat, sprayed or trawled on fireproofing, EIFS systems, and other materials or systems for the same or similar purpose whether done manually or by a piece of machinery or equipment devised to replace the wheelbarrow or buggy, including but not limited to the forklift, tusky hoist, and rigging and signaling for cranes to the point or points of application or installation, making mixing and preparing after delivery all materials used by plasters, whether by hand or machine including but not limited to mixers, pumps for plaster or fire proofing, plaster, finish coats, fireproofing, including Monocoat, Cafco or other materials for the same or similar use, moving any rolling scaffolding, building and handling all necessary trestle, scaffolding and planking of scaffolding for plasterers and lathers, building mortar boxes, mortar boards and stands, and the repairing and maintenance of all equipment either on the job or in the yard, the spreading of all temporary protective drop cloths, building paper or plastic covers and taping of same (in a composite crew with the plasterers when necessary), the cleaning of all floors, and debris, behind the plasterers or any other worker performing plasterers work in connection with the work performed all work necessary for cold weather protection and cure including but not limited to handling installing or tending to blankets, visqueen, and space heaters, and running putty.

Tending to plasterers or any other worker performing plasterers work on EFIS system work shall include all work after the wallboard is installed including but not limited to any preparatory sealing or leveling, placing foam, mesh, and plaster including any rough, finish, and color coats.

For sprayed on fire proofing work only, including Monocoat, Cafco or other materials for the same or similar use an Employer signatory to this Agreement and the Local 169, Laborers Master Agreement may employ Laborers at the Group 1 wage rate to perform overspray protection, the spreading of all temporary protective drop cloths, building paper or plastic covers and taping of same, the cleaning of all floors, and debris, cold weather protection and cure including but not limited to handling installing or tending to blankets, visqueen, and space heaters and moving rolling scaffolding.

Craft: Ironworker (Union Rate)

Prevailing wage rates include the base rate as well as all applicable fringes

Ironworker-Journeyman.....	81.01
Ironworker - Foreman.....	85.63
Ironworker -General Foreman.....	90.71

ADD ZONE RATE

In addition to Iron Worker rates add the applicable amounts per day, calculated based on a road mile from the Reno City Hall or Las Vegas City Hall.

Zone 1	60 to 75 miles	\$20.00
Zone 2	75 to 100 miles	\$25.00
Zone 3	100 miles and over	\$75.00

ADD PREMIUM PAY

One and one half (1X) the regular straight time hourly rate shall be paid:

1. For the first two (2) hours worked in excess of eight (8) on a regular workday Monday-Friday
2. For the first eight (8) hours on Saturday

Double the regular straight time hourly rate shall be paid for all time:

1. For all hours worked over ten (10) hours in one day or shift.
2. For any hours worked on Sunday.
3. For all hours worked over eight (8) on Saturday
4. For all hours worked on Holidays

Shift Pay

1. 2nd shift add 6% of hourly wage
2. 3rd shift add 13% of hourly wage
3. Dedicated shift add 6% of hourly wage

RECOGNIZED HOLIDAYS

New Year's Day, President's Day, Memorial Day, Independence Day, Labor Day, Thanksgiving Day, Day after Thanksgiving Day, Christmas Day.

JOB CLASSIFICATION: Excerpt from Agreement between NV AGC and DC of Ironworkers

Field fabrication and/or erection or deconstruction of structural, ornamental and reinforcing steel, including but not limited to the fabrication, rigging and signaling, erection and construction of all iron and steel, ornamental lead, bronze, brass, copper and aluminum, plastics and all other substitute materials, including, but not limited to, composites, carbon fiber and fiberglass, all barrier railings, handrail, aluminum, steel, glass and plastic, reinforced concrete structures or parts thereof; bridges, viaducts, inclines, dams, docks, dredges, vessels, locks, gates, guides, aqueducts, reservoirs, spillways, flumes, caissons, cofferdams, subways, tunnels, cableways, tramways, monorails, blast furnaces, stoves, kilns, coolers, crushers, agitators, pulverizers, mixers, concentrators, ovens, cupolas, roof decking such as but not limited to "Cofar", "Trusdeck", Mahon "M"; smoke conveyors, penstocks, flag poles, drums, shafting, shoring, fur and storage rooms, fans and hot rooms, stacks, bunkers, conveyors, dumpers, elevators, vats, tanks, enamel tanks, enamel vats, towers, pans, hoppers, plates, anchors, caps, corbels, lintels, Howe and combination trusses, grillage and foundation work, grating, bucks, partitions, hanging ceilings, hangers, clips, brackets, flooring, floor construction and domes, rolling shutters, curtains, frames; aluminum, rolling fire, won and iron doors, including supports; cast tiling, air ducts, duct and trench frames and plates; wire work, railings, wire cable

including pipe, guards, fencing, grill work, sidewalk and vault lights, skylights, roofs, canopies, light steel framing, marquees, awnings and other related equipment elevator and dumb waiter enclosures, elevator cars, tracks, fascias, aprons, operating devices, steel and aluminum sash, hardware and screens, frames, fronts, lockers, racks, book stacks, tables, shelving, metal furniture, seats, chutes, escalators, stairways including pre-engineered stairs, ventilators, boxes, fire escapes, signs, jail and cell work, safes, vaults, vault doors, safe deposit boxes, corrugated sheets when attached to steel frames, including insulation; frames in support of boilers; materials altered in field such as framing, cutting, bending, drilling, burning and welding including by acetylene gas and electric machines; metal forms and false work pertaining to concrete construction; seismic isolation systems and dampening systems including base isolators, sectional water tube and tubular boilers and stokers; traveling sheaves, vertical hydraulic elevators, bulkheads, skip hoists, making and installation of articles made of wire and fibrous rope, rigging in connection with pumps, compressors, forced and induced draft fans, air meters, Bailey meters, agitators, oxygen converters, cinder machines, pelletizing machines, reactor vessels, reactor spheres, completed tanks and assembled sections of completed tanks, scroll cases, refineries, hydroelectric power houses and steam plants, cogeneration plants, vessels and government departments; false work, travelers, scaffolding, pile drivers, sheet piling, derricks and powered derrick swinger including the erection, installation, handling and operating. Cranes erection, installation, handling and operating of same on all forms and types of construction work. The operation of Valla and Spider type battery and/or propane powered portable floor cranes having no operator seat utilized to install ironworker scope of work and the same on all forms and types of construction work. Crane work at the ports, including hammer-head cranes, container cranes and rubber tire cranes. Offloading, relocations, and commissioning of all burning and removal of sea bracing track layout; erection of apex boom extensions, back reach extensions, and rail replacement. Includes all welding, containment and structural modifications of the aforementioned items; railroad bridge work including maintenance thereof; moving, hoisting and lowering of machinery, modules, skid modules and placing of same on foundation, including bridges, cranes, intermittent use forklifts, derricks, buildings, piers and vessels; loading, unloading, necessary maintenance, erection, installation, removal, wrecking and dismantling of all of the above and all reinforcing work and submarine diving in connection with or about same; erection of steel towers, chutes and spouts for concrete where attached to towers and handling and fastening of cables and guys for same; unloading, racking, sorting, cutting, bending, hoisting, placing and tying including the use of any and all mechanical tying devices, burning and welding including stud welding of all iron, steel and metal in reinforced concrete construction including mesh for floor arches and the making of hoops and stirrups, metal forms and metal supports thereof; jacking of slip forms, installation of all wire, cable, parabolic cans, steel and all other materials, including, but not limited to, composites, carbon fiber and fiberglass, used for the purposes of prestressing including grouting of ducts, post stressing concrete girders, beams, columns, etc.; loading, unloading, hoisting, handling, signaling, placing and erection of all prestressed, post stressed, precast materials, G.F.R.C., Dryvit System, including the securing by bolting and/or welding and the installation of steeltex and wire mesh of any type when used for reinforced concrete construction; erection of all curtain wall; glass handrail; stay in place deck; automated and/or mechanical parking structures; offloading, staging, hoisting and setting of modular structures and micro-units; curtain wall systems and associated sealants. Window wall and entrances, panels, insulated and non-insulated, factory and field assembled, porcelain enameled panels, ceramic, laminated spandrelite, louvers and sunscreens; application of thiokol, neoprene and other sealants used to seal materials installed by Iron Workers; installation and handling of phenolic panels, including but not limited to, Trespa products and all similarly related materials and/or systems; installation of metal window stools and sills; installation of aluminum, bronze and steel thresholds; erection and dismantling of all types of cranes and changing of booms; erection of rock, sand and gravel plants, dismantling and loading out conveyors, aggregate plants, batch plants, abseils, refrigeration plants, etc.; erection and dismantling of Monigan walking dragline, launchhammer bucket wheel excavator and other trenching equipment; signaling on highlines, whirley cranes and derricks, buck hoists, man hoists, fork lifts, material towers and scanning antennae; metal and steel supports of all types; fabrication, assembling and erection of offshore drilling platforms or similar installations; dust collectors, precipitators, multi-plate, specialty welding processes, unloading, loading, hoisting, handling and rigging of all building materials delivered to the job

site; hanging ceilings, tees, channels, beams, acoustical elements, sound barriers, computer floors, etc.; installation of stage rigging (including counterweights), curtains, draperies, traverse rods, tracks, cables, window cleaning equipment, powered work platforms, including and loading and unloading, erection installation and removal of powered chassis mounted elevating mast climbing work platforms, rigging in connection with display shows; ski lifts, etc.; wrecking of bridges, viaducts, elevated roads and structural steel and iron in buildings; all steel frames for openings, all porches, verandas, canopies and balconies; all overhead travelers, duo rails, tram rails; erection, setting, repairing of guard or collision rails on bridges and approaches, road ways or any other structures; handling and setting of all types of steel and metal joists, including metal box joists for truss lab and preformed keystone shaped metal joists; erection of steel and metal houses and packaged buildings; all translucent and plastic material on steel frame construction; the erection of solar energy systems, including but not limited to, photo voltaic, heliostat and parabolic systems, energy producing windmill type towers, wind turbine erection to included, but not limited to, prep work, boltup, tensioning or torque of bolts on base and all tower section turbine and blade assemblies; nuclear reactors, electromagnetic shielding plates and atomic vessels including all component parts; the plumbing, aligning and leveling of all materials and equipment through the use of optical instruments, LASER beams, etc., and the use of instruments to establish layout, installation and disposition of ironworker installed scope of work; the unloading, distributing, stockpiling and handling of all materials coming under the jurisdictional claims of the UNION such as to rail heads, storage yards, loading and unloading, hoisting, handling, signaling of all fabricated material and equipment at the jobsite (except FOB deliveries) related to the Iron Workers jurisdiction that is within the individual employers' contractual scope of work including from and to barge and ships to a lay down yard or construction project, etc., shall be done by the Iron Workers.

All reinforcing work in connection with field fabrication, including but not limited to the pre-assembly of reinforcing cages, loading and unloading, handling, racking, sorting, cutting, bending, hoisting, intermittent use of forklifts, placing, burning, welding and tying of all material including the use of any and all mechanical tying devices, or substitute materials, including but not limited to, composites, carbon fiber and fiberglass, stainless steel, used to reinforce concrete construction shall be done by Iron Workers within the individual employers' scope of work at the jobsite, excluding FOB deliveries. A working Iron Worker shall be employed for maintenance on jobs of substantial size while concrete is being poured on reinforcing steel, wire mesh and paper back steeltex but will not be required as a stand-by man. All work in connection with the installation, alignment, repair & modification of panelized roofing systems, pre-engineered fabric structures, aluminum clarifier coverings, carports, ministorages, and dock planks. All work in connection with the installation, alignment, repair and modification of bleachers, planking and stadium seating. All work in connection of installation of amusement rides including, but not limited to, the erection and alignment of all track, machinery and related components.

Craft: Laborer (Union Rate)

Prevailing wage rates include the base rate as well as all applicable fringes

Landscaper	43.37
Furniture Mover	44.87
Group 1.....	48.53
Group 1A.....	46.66
Group 2.....	48.63
Group 3.....	48.78
Group 3A.....	52.21
Group 4.....	49.03
Group 4A.....	51.53
Group 5.....	49.33
Group 6	
Nozzlemen, Rodmen.....	48.33
Gunmen, Materialmen.....	48.33
Reboundmen.....	48.68
Gunit Foreman.....	49.73

ADD ZONE RATE

In addition to LABORER rates add the applicable amounts per hour, calculated based on a road miles from either the Carson City Courthouse or the Washoe County Courthouse:

Zone 1	0 to 75 miles	\$0.00
Zone 2	75 to 150 miles	\$6.00
Zone 3	150 to 300 miles	\$7.00
Zone 4	300 miles or over	\$8.00

ADD PREMIUM PAY

One and one half (1 ½) the regular straight time hourly rate shall be paid:

1. For all hours worked over eight (8) hours in one day or shift.
2. For any hours worked on Saturday from midn ight to midnight.

Double the regular straight time hourly rate shall be paid for all time:

1. For all hours worked over twelve (12) hours in one day or shift.
2. For any hours worked on Sunday from midnight to midnight.
3. For any hours worked on holidays from midnight to midnight.

RECOGNIZED HOLIDAYS

If any of these holidays fall on Sunday, the Monday following shall be considered a Holiday. New Year’s Day, President’s Day, Memorial Day, Fourth of July, Labor Day, Admission Day, Thanksgiving Day, Day after Thanksgiving Day, Christmas Day.

JOB DESCRIPTION: Excerpt from Agreement between AGC and LIUNA Local 169

The construction, erection, alteration, repair, modification, demolition, addition, improvement of all building, heavy and highway, utility, industrial and all other type(s) of construction.

SEE GROUP CLASSIFICATIONS

Craft: LUBRICATION AND SERVICE ENGINEER (MOBILE AND GREASE RACK) (Union Rate)

Prevailing wage rates include the base rate as well as all applicable fringes

Lubrication and Service Engineer (mobile and grease rack).....71.43

ADD ZONE RATE

In addition to: **LUBRICATION AND SERVICE ENGINEER (MOBILE AND GREASE RACK)** rates add the applicable amounts per hour calculated based on a road miles from the Carson City Courthouse or Washoe County Courthouse.

Zone 1	0 to 75 miles	\$0.00
Zone 2	75 to 150 miles	\$5.00
Zone 3	150 to 300 miles	\$6.00
Zone 4	300 miles and over	\$7.00

ADD PREMIUM PAY

1. One and one-half (1-1/2) times the applicable straight-time rate for the day, shift, work, equipment and classification shall be paid for all work (including repair work and field survey work) performed on Saturday and before a shift begins and after it ends, except when operating equipment servicing a craft that is receiving double time on commercial building construction, in which case double time shall be paid.
2. Overtime. The following rates shall apply on Sundays and holidays and all work before a shift begins and after it ends:

RECOGNIZED HOLIDAYS

Holidays. Double the applicable straight-time rate shall be paid for all work (including repair, maintenance and field survey work) performed on Sundays and the following holidays: New Year's Day (January 1); Memorial Day (last Monday in May); Independence Day (July 4); Labor Day (1st Monday in September); Nevada Admission Day (last Friday in October); Thanksgiving Day (4th Thursday in November); the day after Thanksgiving Day; and Christmas Day (December 25). Holidays falling on Sunday shall be observed on the following Monday. Holiday hours shall be reckoned on the same basis as Sunday hours.

Saturday Shift Period. On any shift, Saturday shall be the twenty-four-hour period commencing at 12:00 midnight Friday.

Sunday Shift Period. On any shift, Sunday shall be the twenty-four-hour period commencing at 12:00 midnight Saturday.

3. For hours worked in excess of 12) on any such workday, an Employee shall be paid two (2) times the regular straight-time rate of pay for each hour so worked.

Craft: Mechanical Insulator (Union Rate)

Prevailing wage rates include the base rate as well as all applicable fringes

Mechanical Insulator-Mechanic.....	75.52
Mechanical Insulator-Foreman.....	79.52
Mechanical Insulator-General Foreman	81.52

ADD ZONE RATE

In addition to MECHANICAL INSULATOR rates add the applicable amounts per DAY, calculated based on a radius figured from Reno City Hall:

Zone 1	0 to 20 miles	\$15.00
Zone 2	21 to 40 miles	\$25.00
Zone 3	41 to 60 miles	\$35.00
Zone 4	Over 60 miles	\$100.00
Zone 4: Up to \$140.00 per day with receipts		

ADD PREMIUM PAY

One and one half times the minimum hourly wage rate shall be paid for the first two (2) hours of overtime work, directly following eight (8) hours Monday through Friday, and for the first ten (10) hours worked on Saturdays. Double the minimum hourly wage rate shall be paid for all other overtime worked Monday through Friday and in excess of ten (10) hours on Saturdays.

RECOGNIZED HOLIDAYS

New Year's Day, President's Day, Good Friday, Memorial Day, Independence Day, Labor Day, Veteran's Day, Thanksgiving Day, Day after Thanksgiving Day, Christmas Day.

JOB DESCRIPTION: Excerpt from the Int'l Assoc. of Heat and Frost Insulators and Allied Workers Local 16 and the No. CA Chapter. Western Insulation Contractors Assoc.

- 65. Lining of all mechanical room surfaces and air handling shafts.
- 66. The filling and damming of fire stops and penetrations including, but not limited to, electrical and mechanical systems.
- 67. All foam applications for the purpose of thermal, acoustical, or fire protective purposes, including RTV foams or equivalents, applied to mechanical or electrical systems.
- 68. All duct lining, and duct wrapping, done on the job site, direct application and installation of fire protection of grease ducts, exhaust systems, or any other ductwork for acoustical or thermal purposes.
- 69. The insulation of all field joints on pre-insulated underground piping, and the pouring of Gilsilite or its equivalent.
- 70. Any finish material which is contiguous to the thermal or acoustical application.
- 71. The preparation, distribution of materials on job sites, assembling, molding, spraying, pouring, mixing, hanging, adjusting, repairing, dismantling, reconditioning, maintaining, finishing, and weather proofing of hot or cold thermal or acoustical insulation with such materials as may be specified.
- 72. The application of any material, including metal and PVC jacketing, Alumaguard or equivalent, on piping, fittings, valves, flanges, boilers, ducts, plenums, flues, tanks, vats, equipment and any other hot or cold surface for the purpose of thermal control.
- 73. The Agreement shall cover all other work of a specialty nature.

Craft: MILLWRIGHT (Union Rate)

Prevailing wage rates include the base rate as well as all applicable fringes

Millwright Journeyman.....	73.97
Millwright Welder.....	76.97
Millwright Foreman.....	78.46
Millwright General Foreman.....	83.40

ADD ZONE RATE

In addition to MILLWRIGHT rates add the applicable amounts per hour, calculated from Reno, Nevada City Hall. The Employer agrees to provide each employee zone pay as established below if the project is further than forty-five (45) miles calculated via the "shortest route" filter using Google Maps from the address of city hall of respective dispatch points.

Zone 1	Up to 45 Miles	\$0.00
Zone 2	More than 45 miles but less than 101 Miles	\$4.00
Zone 3	101 or more Miles	\$6.00

ADD PREMIUM PAY

Monday through Friday, the first four (4) hours of overtime after eight (8) hours of straight-time work shall be paid at one and one half (1½) times the straight-time rate of pay. All additional overtime will be paid at two (2) times the straight-time rate of pay.

All work performed on Sunday and Holidays shall be paid at two (2) times the straight-time rate of pay. Any work performed on Labor Day shall be paid at triple (3x) the regular straight time hourly wage rate.

Lodging: If the project is further than forty-five (45) miles calculated via the "shortest route" filter using Google Maps from the address of city hall of the respective dispatch points listed above, the Employer agrees to furnish acceptable single occupancy lodging to each employee. Employers are encouraged to use commercial facilities and lodges, however, when such facilities are not available, per diem in lieu of room and lodging shall be paid at the rate of one hundred ten dollars (\$110.00) per day, or part thereof, from the date of hire for the project to the date of termination of employment on the project.

RECOGNIZED HOLIDAYS

New Year's Day, Washington's Birthday (President's Day), Memorial Day, 4th of July, Labor Day, Veteran's Day, Thanksgiving Day, Friday after Thanksgiving, Christmas Day.

JOB DESCRIPTION Excerpt from Southwest Regional Council of Carpenters' Millwright Regional Master Construction Agreement.

Section 1.4 Millwright Jurisdiction.

The machinery, equipment, processes and associated components listed below which are identified for the purpose of description only, falls within the jurisdiction of the United Brotherhood of Carpenters and Joiners of America (Millwrights). Although some components of machinery and/or equipment may be described in one application or location and not in another, it shall not be excluded from our craft jurisdiction when, to avoid repetition, it is not described in other applications, and such jurisdiction shall be applied to the initial commissioning, maintenance, decommissioning, and recommissioning of all associated machinery and/or equipment.

Section 1.4.1

Millwright craft jurisdiction shall include the loading, unloading, hoisting, rigging by any means, transferring, moving, cleaning, disassembling, assembling, moving and setting and removal of skids, welding, burning, erecting, calibrating, precision grouting, supporting, aligning, starting-up and testing, adjusting, repairing, and the maintaining of all machinery and equipment, be it powered by, or receiving power from, steam, gas, gasoline, diesel, biodiesel,

hydrogen, jet, electric, pneumatic, magnetism, adiabatics, diabatics, isothermics, water, hydropnuematics, solar, thermal, mineral, atomic, rocket, nuclear, chemical, wind, waste product of any kind or any other source, regardless of whether or not such machinery or equipment is temporarily or permanently installed or located.

Section 1.4.2

Millwright craft jurisdiction shall include all activities necessary to: set all engines, motors, dynamos, generators, diesel generators, motor restraints and supports; install, measure and align with optical and/or electronic instruments when necessary the reactors, control, push and shut-down rods, rod pressure housing, drives, guide sleeves and other related equipment in reactors, turbines, castings, combustion chambers and all its related components; the attachment and final connection of the inlet manifolds and exhaust ducts, cylinders, diaphragms, gaskets, containment barriers, rotors, blade rings, blade or bucket assemblies, hydrogen coolers, blower assemblies, packing joints on hydrogen coolers, exciter or Alterex and all others, turning gear, extension box, welding of extension box, lagging, stretching of coupling bolts or others; perform oil flush; install turbine lube oil tank, pumps and related component skids, filters, thrust bearings, magnetic bearings, the sweating on and shrinking of bearings, couplings, shafts and others, sole plates and machine bases; perform all precision grouting using the following materials: epoxy, wet, non-shrink, dripacking or other types; perform demineralizing and hydromation; install mechanical dust systems, sensors, air compressors, super charges, coolers, boiler controls and linkage, thermal management systems, Bailey Meters or similar devices and their linkages; installation, maintenance and removal of all instrumentation, gauges, antennae and other communication devices, fluid drives, power drive trains, embedded guides for traveling screens, traveling screens, roller, slide, knife, lock and sluice gates, limit torques on mechanical valves, gates and others, tainter valves, limit switches, trips, triggers or switches, including the brackets that are attached to, stop logs, dam rollers, transfer cars and gear head motors.

Section 1.4.3

The setting of variable drives, fans, coal cranes, truck cranes or other types, including servicing and the adjusting and aligning of mechanical equipment within the cranes, crane rails and all other types of rails which would carry mechanically activated equipment, including their alignment, installation, removal, servicing, and alignment of hydraulic and pneumatic lifts and passenger boarding bridges, monorail (all sizes), magnetic propulsion systems, trolleys, pumps and their associated components, packaging equipment, refrigerating equipment, chillers, and related equipment, lantern rings, packing glands, packing for pumps, pollution equipment, carbon absorbers and filtration, heat exchanges, grain, ball, hammer, roller mills, pulverizers and others, crushers and beaters, hoppers, bins, chutes and spouts, turn tables, shears, casing machines, robots, air-veyors, conveyors of all sizes, types, and styles regardless of the materials they are constructed with, or mechanically powered conveyances of any type, including their supports, people movers, x-ray and imaging & scanning machines, elevator and platform lifts, dock levelers and locks, roll-up and sectional doors, operable partitions, retractable roofs, magnetic separators, hoists, feeding machinery, Z-loaders, S-loaders, palletizers, Triax equipment, mechanical equipment in scrubbers, pack towers, precipitators, cooling towers and air cooled condensers.

Section 1.4.4

Sewage, Brackish, Desalination, Water Treatment and Mineral Extraction Plants — the disassembly, fabricating, rigging, erecting and aligning of skimmers, rake mechanisms, feed wells, baffles, scum troughs, de-gritting equipment, bar screens, communitors, mixers, pumps, aeration systems, blowers, membrane filtration systems, sequencing batch reaction systems, including related, filter presses, sand filtration systems, ultra violet rack systems, mechanical drive assemblies, conveyors, lines, piping, flanges, brackets, supports, mono rails, gates and setting odor control and detection equipment, (excluding heating, ventilating and air conditioning work). The setting of thru-clean bar, straight line bar, trash, tritor drum, and disc screens, straight line grit, circuline grit, circuline sludge, and circuline mixer collectors, straight line, flash, horizontal slow, vertical slow, and vibra flow feeder machines, pre-aeration and settling tanks, covers for tanks, bowls and basins including stationary or mechanical covers regardless of materials, thickeners, rotoline distributors, sludge bed and settling pond cleaners, digestion systems, heaters, dyna-grind sewage screening grinders, screw pumps, spiral classifier, agitators, junk remover, hydro pulper, cooling fans, lube systems, selectifier screens, hydrosensors, fuel blowers, grizzly screens, trommels, table feeders, dryers, optical sorters, high tension separators, grip dewatering screens, flash mixer, horizontal slow mixer, vertical slow mixer, filter, cone and rotary presses, comminutors, barminutors, degreasers, rotometers, dehumidifiers, benches, pressure cleaning systems & devices, washers for cars, trucks, buses, trains, planes unmanned and autonomous vehicles and other types, hydraulic, servo and pneumatic units, shroud boxes, silencers, scales, load cells, eddy current clutches, disintegrators, dehairing machines, grain handling devices, laboratory equipment, machine shop equipment, ladle cars, stunning pens and doors and gates, activation equipment, racks, material handling platforms, access & egress platforms, catwalks,

transition pieces, the handling and installation, of pulleys, gears, fluid couplings, sheaves and fly wheels, air vacuum, worm, belt, friction, rope, magnetic, chain and gear drives that are directly or indirectly coupled to motors, belts, chains, shafts, or screws, installation of legs, boots, guards and boot tanks, all bin and diverter valves, turn hands and indicators, shafting, bearing cable sprockets, cutting of all key seats in old and new work, troughs, chippers, calenders, rolls, winders, rewinders, slitters, cutters, wrapping machines, blowers, forging machines, pneumatic, electric and hydraulic rams, servo actuators, extractors, expellers and extruders, ball and dust collectors, splicing of ropes and cables.

Millwright craft jurisdiction on energy generation facilities shall include all loading, unloading, movement, hoisting, preparation, uncrating, preparation of nacelle units prior to installation or removal, installation, setting, removal, alignment, and final torquing and tensioning of any mechanical component used in the generation of power, including any incidental wiring or piping. This shall include all aspects of power trains, drive and tracking systems, elevation and azimuth drives, energy collection optimization systems, all rams, dampers and other stabilization devices, antennae, bearing housing assemblies and units, actuators, pulleys, gears, access points, rotational connections, mounting and alignment of tracks, axles, bearings, rotational joints, or any other device which allows for the automated or manual movement of equipment post-installation, all turbines, and wind, wave and tidal analysis equipment. It shall also include all work associated with energy collection and storage facilities, including the loading, unloading, movement, hoisting, preparation, installation, setting, and alignment of racking systems, torque tubes, modules, batteries, energy storage systems, cooling or control systems, inertia systems or other equipment or machinery, and all incidental wiring or piping thereof.

Section 1.4.5

The laying out, fabrication and installation of protecting equipment including: machinery guards; the making and setting of templates for machinery; the fabrication of bolts, nuts, pans; the drilling or creating of holes in machinery for any equipment which the Millwrights install, remove, service or inspect, regardless of material; installation of all methods of access and egress and safety devices whether temporary or permanent; all welding and burning regardless of type; the fabrication of all lines, hose or tubing used in the lubrication, operation, cooling or heating of machinery, including the installation of all fluids used to operate, lubricate, cool or heat equipment installed by Millwrights; the cleaning or pressure cleaning of machinery; the machining, grinding, milling, broaching, boring, threading, lapping, field machining, technical bolting and keying that may be necessary for any part of equipment, including the starting up, breaking in, trial running and operational or functional testing of any equipment or machinery installed or handled by the Millwrights, the initial programing of robotics for startup, and the incidental connection and disconnection of machinery and equipment from piping and electrical systems.

Section 1.4.6

Rock, sand and gravel plants, mineral processing plants and batch or aggregate plants: Installation, removal and maintenance of all recycling equipment, separators, centrifuges, classifiers, grates, crushers, conveyors, chutes or piping from one piece of mechanical equipment into another piece of mechanical equipment, or from a vessel into a conveyor, or into other places or mechanical equipment or other mechanical equipment used (for the purpose of description only) to excavate material from one area to another from highways, roadways, waterways or elsewhere.

Section 1.4.7

When optical instruments such as total stations or similar devices, automatic levels, builder's transits, precision jig transits, tilting levels, theodolites or other precision tools and instruments are used to locate, set, scan-to-BIM or as-Built measure and verify machines, these tools are considered a tool of the Millwright trade and are to be used by Millwrights to set the equipment or machinery.

Section 1.4.8

Incidental asbestos removal on equipment in which Millwrights normally remove during maintenance and repair work.

Section 1.4.9

Any new equipment or technology designed to replace any of the equipment described above shall remain in the craft jurisdiction of the Millwrights.

Craft: OPERATING ENGINEER (Union Rate)
Prevailing wage rates include the base rate as well as all applicable fringes

Operating Engineers	(SEE GROUP CLASSIFICATIONS)	
Group 1.....		66.41
Group 1A.....		69.17
Group 2.....		69.70
Group 3.....		69.97
Group 4.....		70.71
Group 5.....		71.01
Group 6.....		71.18
Group 7.....		71.43
Group 8.....		72.02
Group 9.....		72.34
Group 10.....		72.69
Group 10A.....		72.88
Group 11.....		73.12
Group 11A.....		74.76
Group 11B.....		75.57
Foreman.....		74.76
Add 12.5% to base rate for "Special" Shift		

Add Operating Engineers Zone Pay
Add Premium Pay

Craft: OPERATING ENGINEER (Union Rate)
STEEL FABRICATOR & ERECTOR

Prevailing wage rates include the base rate as well as all applicable fringes

Operating Engineers	(SEE GROUP CLASSIFICATIONS)	
Group 1.....		81.71
Group 1 Truck Crane Oiler.....		75.54
Group 1 Oiler.....		73.58
Group 2.....		80.20
Group 2 Truck Crane Oiler.....		75.29
Group 2 Oiler.....		73.37
Group 3.....		78.96
Group 3 Truck Crane Oiler.....		75.07
Group 3 Oiler.....		73.15
Group 3 Hydraulic.....		74.74
Group 4.....		77.23
Group 5.....		76.13
Add 12.5% to base rate for "Special" Shift		

Add Operating Engineers Zone Pay
Add Premium Pay

Craft: OPERATING ENGINEER (Union Rate)
PILEDRIVER

Prevailing wage rates include the base rate as well as all applicable fringes

Operating Engineers	(SEE GROUP CLASSIFICATIONS)
Group 1.....	81.18
Group 1 Truck Crane Oiler.....	75.72
Group 1 Oiler.....	73.80
Group 2.....	79.64
Group 2 Truck Crane Oiler.....	75.51
Group 2 Oiler.....	73.60
Group 3.....	78.19
Group 3 Truck Crane Oiler.....	75.29
Group 3 Oiler.....	73.37
Group 4.....	76.68
Group 5.....	75.57
Group 6.....	72.29
Group 7.....	73.50
Group 8.....	72.54
Add 12.5% to base rate for "Special" Shift.....	

ADD ZONE RATE

In addition to: **OPERATING ENGINEER, STEEL FABRICATOR & ERECTOR, and OPERATING ENGINEER PILEDRIVER**, rates add the applicable amounts per hour calculated based on a road miles from the Carson City Courthouse or Washoe County Courthouse

Zone 1	0 to 75 miles	\$0.00
Zone 2	75 to 150 miles	\$5.00
Zone 3	150 to 300 miles	\$6.00
Zone 4	300 miles over	\$7.00

ADD PREMIUM PAY

1. One and one-half (1-1/2) times the applicable straight-time rate for the day, shift, work, equipment and classification shall be paid for all work (including repair work and field survey work) performed on Saturday and before a shift begins and after it ends, except when operating equipment servicing a craft that is receiving double time on commercial building construction, in which case double time shall be paid.

2. Overtime. The following rates shall apply on Sundays and holidays and all work before a shift begins and after it ends:

RECOGNIZED HOLIDAYS

Holidays. Double the applicable straight-time rate shall be paid for all work (including repair, maintenance and field survey work) performed on Sundays and the following holidays: New Year's Day (January 1); Memorial Day (last Monday in May); Independence Day (July 4); Labor Day (1st Monday in September); Nevada Admission Day (last Friday in October); Thanksgiving Day (4th Thursday in November); the day after Thanksgiving Day; and Christmas Day (December 25). Holidays falling on Sunday shall be observed on the following Monday. Holiday hours shall be reckoned on the same basis as Sunday hours.

Saturday Shift Period. On any shift, Saturday shall be the twenty-four-hour period commencing at 12:00 midnight Friday.

Sunday Shift Period. On any shift, Sunday shall be the twenty-four-hour period commencing at 12:00 midnight Saturday.

3. For hours worked in excess of 12) on any such workday, an Employee shall be paid two (2) times the regular straight-time rate of pay for each hour so worked.

JOB DESCRIPTION, includes but is not limited to:

Operate one or several types of power construction equipment, such as motor graders, bulldozers, scrapers, compressors, pumps, derricks, shovels, tractors, or front-end loaders to excavate, move, and grade earth, erect structures, or pour concrete or other hard surface pavement.

Craft: PAINTER (Union Rate)

Prevailing wage rates include the base rate as well as all applicable fringes

Brush/Roller Painter.....	49.79
Spray Painter/Paperhanger.....	51.50
Sandblaster.....	51.55
Structural Steel & Steeplejack.....	51.55
Swing Stage.....	49.30
Special Coating Application-Brush.....	49.35
Special Coating Application-Spray.....	49.35
Special Coating Application-Spray Steel.....	53.29
Foreman.....	\$1.00 above highest Journeyman

ADD PREMIUM PAY

One and one half (1 ½) the regular straight time hourly rate shall be paid:

1. For all hours worked over eight (8) hours in one day or shift unless the Union is notified when four (4) tens (10's) are instituted.
2. For any hours worked on Saturday from midnight to midnight
3. For any work performed in excess of the regular work week of forty (40) hours.

Double the regular straight time hourly rate shall be paid for all time:

1. For any hours worked on Sunday from midnight to midnight
2. For any hours worked on holidays from midnight to midnight

RECOGNIZED HOLIDAYS

New Year's Day, President's Day, Memorial Day, Independence Day, Labor Day, Veteran's Day, Thanksgiving Day, Day after Thanksgiving Day, Christmas Day.

JOB DESCRIPTION: Excerpt from Agreement between Painters and Allied Trades DC 16 and Independent Flooring Contractors of No Nevada

a. All painting of residences, buildings, structures, industrial plants, tanks, vats, pipes, vessels, bridges, light poles, high tension poles, traffic and parking lines on highways, parking lots, playgrounds, factories, and air line strips; all sign, pictorial, coach, car automobile, carriage, aircraft machinery, ship and railroad equipment, mural and scenic painting; spackling of all surfaces where adhesive materials are used; and all drywall pointing, taping and finishing.

b. All decorators, paperhangers, hard wood finishers, grainers, glaziers, varnishers, enamellers

1. Paperhangers work shall be all material of whatever kind or quality applied to walls or ceilings with paste or adhesive; all tacking on the muslin or other materials which is used as wall or ceiling coverings or covered with material pasted on.

2. The scraping off of old paper, preparing of walls, etc., for paper hangers work.

3. The application of relief, stucco, plaster or decorative work shall not be considered paperhanger's work exclusively.

(c) All men engaged in applying or removing paints, pigments, extenders, metal primers and metal pigments, clear pigments, binders, thinners and dryers, primers and sealers, oil paints and enamels, water

colors and emulsions, clear coatings, waxes, stains, mastics, cement enamels and other special coatings, plastics, adhesives, coatings and sheet rubber and other linings, oils, varnishes, water colors, wall paper, wall coverings or other materials used in the various branches of the trade, and the cleaning and bleaching of all interior and exterior walls and surfaces with liquid, steam, sandblast or any other process and all work incidental thereto.

Craft: PILEDRIVER (Union Rate)

Prevailing wage rates include the base rate as well as all applicable fringes

Piledriver-Journeyman.....	58.92
Piledriver-Welder.....	59.92
Piledriver-Foreman.....	62.61
Piledriver-General Foreman.....	66.67
Tender.....	62.61
Stand-By Diver.....	63.61
Diver-Diving (Wet Pay).....	105.18

ADD ZONE RATE

In addition to PILEDRIVER rates add the applicable amounts per hour, calculated from the Washoe County Courthouse:

Zone 1	Within 75 miles	\$0.00
Zone 2	Between 75 to 150 road miles	\$6.00
Zone 3	Between 150 to 300 road miles	\$7.00
Zone 4	In excess of 300 road miles	\$8.00

Workmen performing outside of the free zones shall receive the appropriate remote area allowance for not less than eight (8) hours per day. Remote area differential shall be considered part of the basic wage rate for the purpose of computing overtime hourly wage rates.

ADD PREMIUM PAY

First two (2) hours outside the regular constituted shift shall be at the rate of time and one-half (1½X). Saturdays up to the first twelve (12) hours shall be at the rate of time and one-half (1½X). All additional hours and Sundays and holidays shall be the rate of double time (2X). No work shall be performed on Labor Day, except to preserve life and property.

RECOGNIZED HOLIDAYS

New Year's Day, Memorial Day, 4th of July, Labor Day, Admission Day, Thanksgiving Day, the Friday after Thanksgiving, Christmas Day.

JOB DESCRIPTION

104.1 The Carpenters claim the layout, rigging, tagging, signaling, cutting, burning, welding, chain sawing, driving, setting and pulling of all soldier piles and soldier beams together with all necessary waling, shoring, underpinning, struts, bracing, capping and lagging necessary for construction of subterranean structures of all types to include, but not limited to subways, subway stations, buildings, storm drains, sewers, pipelines and all open cut and cover construction projects. The Carpenters further claim construction of all covers and access mats to include all necessary rigging for setting and removing, whether intermittently or regularly and installation and removal of timber decking.

(a) In addition to the work identified in Article I, the Pile Divers claim the operation of the following types of equipment when the operation of same is incidental to that work which falls under the jurisdiction of the United Brotherhood of Carpenters and Joiners of America or Pile Drivers Local Union No. 2375; mechanical forklifts of all types, boom trucks and any other mobile equipment as assigned by the employer necessary to complete the work. In addition, the operation of the power pack and vibratory hammer controls when driving or pulling, sheet pile, pile, soldier beams, cassinos or casing. . The work includes work on cast & drill holes and operation of the ABI machine.

(1) In the construction of waterfront and marine facilities, such as docks, piers, wharves, bulkheads, jetties, and similar structures, the pile driver classification should continue to apply, up to and including the decking thereof.

- (2) On all pile driving and caisson work on both land and water, the Pile Driver classification should apply.
- (3) In the construction of wooden bridges whether over land or over water, when composed of heavy timber, the Pile Driver classification should apply.
- (4) In the construction of concrete or steel bridges over land, the Pile Driver classification shall apply to the driving of piles and/or caisson work including the forms required for the capping of the piles or caissons immediately top of the piles or caissons. The capping of the piles is herein interpreted as being that concrete, wood, or other material resting on the top of the piles where driven or placed and does not include any further form work above the capping. In many instances it has been found that the capping is called the girder. The above shall apply on such concrete or steel bridges constructed over land, highways, railroads, overpasses and include cloverleaves, interchanges, etc.
- (5) In the construction of concrete or steel bridges over water, the Pile Driver classification shall apply up to and including all of the form work to the top of the column, piers, or abutments supporting the steel and/or any other superstructures.
- (6) In the erection of false work, when necessary for the support of work under the Pile Driver classification, then such false work shall fall within their classification. False work necessary for the support of work under the Carpenter classification shall be done within such Carpenter classification, with the exception that where pile driving or power equipment is used for heavy timber false work, then such work shall come under the Pile Driver classification. This would include all rigging, signaling and tagging incidental to the placing of the heavy timber.
- (7) In the construction of open-cut sewers, the Pile Driver classification shall apply on all piling including wood, steel or concrete sheet piling, all bracing timber and form work incidental to the construction thereof.

Craft: PLASTERER (Union Rate)

Prevailing wage rates include the base rate as well as all applicable fringes

Plasterer-Journeyman.....	.52.62
Plasterer-Foreman.....	.55.93

ADD ZONE RATE

In addition to PLASTERER rates add the applicable amounts per hour, calculated from the South Virginia and Mill Street, Reno, Nevada:

Zone 1	0 to 70 miles	\$0.00
Zone 2	70 miles and over	\$8.00

ADD PREMIUM PAY

OVERTIME Eight (8) consecutive hours (exclusive of a meal period) shall constitute a day's work at straight time. Five (5) consecutive days of eight (8) consecutive hours (exclusive of a meal period), Monday through Friday, shall constitute a week's work. One and one half (1 ½) the regular straight time hourly rate shall be paid for all work over eight (8) hours. Sunday will be paid at double the regular straight time rate.

RECOGNIZED HOLIDAYS

All work performed on the following holidays shall be paid for at double the regular straight time rate: New Year's Day, Memorial Day, Fourth of July, Labor Day, Admissions Day, Thanksgiving Day and the Friday after Thanksgiving and also Christmas Day.

If any of the above holidays fall on Sunday, the Monday following shall be considered a holiday.

No work shall be permitted on the Fourth of July or Labor Day, regardless of compensation or donation, except in case of emergency or to protect life and property. Permission to work shall be granted by the representative of the Union or its officer.

JOB DESCRIPTION: Excerpt from Agreement No NV. Plasterers Master Labor Agreement

This includes but is not limited to:

1. All building construction, including but not limited to the construction, erection, alteration, repair, modification, demolition, addition, or improvement in whole or in part of any building structures,
2. All interior or exterior plastering construction, restoration, repair and inspection of cement, stucco, stone imitation or any patent material when ornamental molded plaster, and the setting of same. All specialty finishes such as veneer, venetian, marmoreno and grasello. All custom and specialty finishes, including but not limited to custom rock, carved plaster, brick and block veneer, stone and wood. Smooth and finish surfaces of full system E.I.F.S. including sticking and shaping of foam pieces or surfaces by adhesive or mechanical installation. All spray or toweled on fireproofing, including cementitious and intumescent products. All plaster acoustical finish systems including, but not limited to, BASWA Phon and Fellert.
3. All work processes which represent technological change, replacement, modification or substitution for the work described above. In addition, all work and use of new materials or *2020-2024 Reno Plasterers Master Labor Agreement* 4 techniques involved in plaster construction including but not limited to what is known as green or sustainable construction technology.

Craft: PLUMBER/PIPEFITTER (Union Rate)

Prevailing wage rates include the base rate as well as all applicable fringes

Plumber/Pipefitter-Journeyman.....	71.10
Plumber/Pipefitter-Foreman.....	75.79
Plumber/Pipefitter-General Foreman.....	80.48

ADD ZONE RATE

In addition to PLUMBER/PIPEFITTER rates add the applicable amounts per statute air mile radius from the Nevada freeway interchange of Interstate 80 and 580.

Zone 1	0 to 75	\$0.00
Zone 2	Over 75 miles	\$8.00

A separate free zone will be established for employees permanently residing and working within a seventy-five (75) statute air mile radius of the Elko, Nevada Post Office.

Zone 1	0 to 75	\$0.00
Zone 2	Over 75 miles	\$8.00

ADD PREMIUM PAY

Premium pay for hours worked in excess of a shift of 8 hours or 12 hours or such other time increment set forth in the Collective Bargaining Agreement or on a weekend or holiday.

RECOGNIZED HOLIDAYS

New Year's Day, Memorial Day, Fourth of July, Labor Day, Nevada Admission Day, Thanksgiving Day, the Friday after Thanksgiving Day, Day Before Christmas and Christmas Day and any Friday preceding a Holiday falling on a Saturday, if worked, holidays shall be compensated at the double time rate.

JOB DESCRIPTION Excerpt from Agreement between LU 350 of United Assoc. of Journeymen and Apprentices of the Plumbing and Pipefitting Industry of United States and Canada

Installation of all heating and refrigeration systems and competent parts thereof, including fabrication, assembling, erection installation, dismantling, repairing, reconditioning, adjusting, altering servicing, handling, distributing, and tying on all piping materials appurtenances and equipment by method, including all hangars and supports of every description, all other work including the the trade relevant to oil burner and all other types of heating and refrigeration equipment including low voltage controls.

Craft: REFRIGERATION MECHANIC (Union Rate)

Prevailing wage rates include the base rate as well as all applicable fringes

Refrigeration-Journeyman.....	64.64
Refrigeration -Foreman.....	68.53
Refrigeration -General Foreman	72.41

ADD PREMIUM PAY

Premium pay for hours worked in excess of a shift of 8 hours or 12 hours or such other time increment set forth in the Collective Bargaining Agreement or on a weekend or holiday.

RECOGNIZED HOLIDAYS

New Year's Day, Memorial Day, Fourth of July, Labor Day, Nevada Admission Day, Thanksgiving Day, the Friday after Thanksgiving Day, Day Before Christmas and Christmas Day and any Friday preceding a Holiday falling on a Saturday, if worked, holidays shall be compensated at the double time rate.

JOB DESCRIPTION Excerpt from Agreement between LU 350 of United Assoc. of Journeymen and Apprentices of the Plumbing and Pipefitting Industry of United States and Canada

Installation of all heating and refrigeration systems and competent parts thereof, including fabrication, assembling, erection installation, dismantling, repairing, reconditioning, adjusting, altering servicing, handling, distributing, and tying on all piping materials appurtenances and equipment by method, including all hangars and supports of every description, all other work including the trade relevant to oil burner and all other types of heating and refrigeration equipment including low voltage controls.

Craft: ROOFER (Non-Union Rate)
(Does not include sheet metal roofs)

Prevailing wage rates include the base rate as well as all applicable fringes

Rofer-Journeyman.....33.64

JOB DESCRIPTION

Includes but is not limited to:

1. Installing and covering roofs and structures with slate, asphalt, wood and other related materials, other than sheet metal, by using brushes, knives, punches, hammers and other tools;
2. Spraying roofs, sidings and walls with material to bind, seal, insulate or soundproof sections of a structure;
3. Installation of all plastic, slate, slag, gravel, asphalt and composition roofing, and rock asphalt mastic when used for damp and waterproofing;
4. Installation of all damp resisting preparations when applied on roofs with mop, three-knot brush, roller, swab or spray system;
5. All types of preformed panels used in waterproofing;
6. Handling, hoisting and storing of all roofing, damp and waterproofing materials;
7. The tear-off and/or removal of roofing and roofing materials.

Craft: SHEET METAL WORKERS (Union Rate)

Prevailing wage rates include the base rate as well as all applicable fringes

Sheet Metal Worker Journeyman.....	73.87
Sheet Metal Worker Foreman.....	78.26
Sheet Metal Worker General Foreman.....	82.65

ADD ZONE RATE

In addition to SHEET METAL rates add the applicable amounts per hour, calculated based on a road from the courthouse in Reno, Nevada:

Zone 1	0 to 75 miles	\$0.00
Zone 2	75 to 100 miles	\$5.00
Zone 3	Over 100 miles	\$10.00 the employee shall be provided reasonable lodging and meal expenses.

ADD PREMIUM PAY

All hourly rates are subject to Over Time (One and one half 1 ½) of the Regular rate:

1. For all hours worked over Eight (8) Hours in one day or shift.
2. For the first Eight (8) Hours work on Saturday.

All hourly rates are subject to Double Time of the Regular Rate:

1. For all hours worked over Ten (10) Hours in one day or shift.
2. For all hours worked over Eight (8) Hours on Saturday.
3. For all hours worked on Sunday, New Year’s Day, President’s Day, Memorial Day, Independence Day, Labor Day, Nevada Day, Thanksgiving Day, Day after Thanksgiving, Day before Christmas, and Christmas Day.

RECOGNIZED HOLIDAYS

New Year’s Day, President’s Day, Memorial Day, Independence Day, Labor Day, Nevada Day, Thanksgiving Day, Day after Thanksgiving, Day before Christmas, and Christmas Day

JOB DESCRIPTION: Excerpt from Sheet Metal Local 26 Collective Bargaining Agreement

(a) manufacture, fabrication, assembling, handling, erection, installation, dismantling, conditioning, adjustment, alteration, repairing and servicing of all ferrous or nonferrous metal work and all other materials used in lieu thereof and of all HVAC systems, air veyor systems, exhaust systems, and air-handling systems regardless of material used including the setting of all equipment and all reinforcements in connection therewith; (b) all lagging over insulation and all duct lining; (c) testing and balancing of all air-handling equipment and duct work; (d) the preparation of all shop and field sketches whether manually drawn or computer assisted used in fabrication and erection, including those taken from original architectural and engineering drawings or sketches; (e) metal exterior wall systems, metal roofing; and (f) all other work included in the jurisdictional claims of International Association of Sheet Metal, Air, Rail and Transportation Workers.

Craft: SOILS and MATERIAL TESTER (Non-Union Rate)

Prevailing wage rates include the base rate as well as all applicable fringes

Soil Tester (Certified).....	46.81
Soils and Materials Tester.....	46.81

Craft: SPRINKLER FITTER (Union Rate)

Prevailing wage rates include the base rate as well as all applicable fringes

Sprinkler Fitter-Journeyman.....	65.31
Sprinkler Fitter Foreman.....	68.31
Sprinkler Fitter General Foreman.....	70.56

ADD ZONE RATE

In addition to SPRINKLER FITTER rates add the applicable amounts per hour, calculated based on a road from the courthouse in Reno, Nevada:

Zone 1	0 to 60 miles	\$0.00
Zone 2	60 to 80 miles	\$23.00
Zone 3	80 to 100 miles	\$33.00
Zone 4	Over 100 miles	\$125.00

JOB DESCRIPTION

Installing, dismantling, maintenance, repairs, adjustments and corrections of all fire protection and fire control systems including the unloading, handling by hand, power equipment and installation of all piping or tubing, appurtenances and equipment pertaining thereto, including both overhead and underground water mains, fire hydrants and hydrant mains, standpipes, and hose connections to sprinkler systems, sprinkler tank heaters, air lines and thermal systems used in connection with sprinkler and alarms systems, also all tanks and pumps connected thereto. Also including shall be CO2 and Cardox Systems, Dry Chemical Systems, Foam Systems and all other fire protection systems, but excluding steam fire protection systems.

Craft: SURVEYOR (Union Rate)

Prevailing wage rates include the base rate as well as all applicable fringes.

Rodman/Chainman	69.97
Instrumentman.....	71.43
Chief of Party Surveyor.....	72.69

ADD ZONE RATE

In addition to: **OPERATING ENGINEER, STEEL FABRICATOR & ERECTOR, and OPERATING ENGINEER PILEDRIVER**, rates add the applicable amounts per hour calculated based on a road mile from the Carson City Courthouse or Washoe County Courthouse

Zone 1	0 to 75 miles	\$0.00
Zone 2	75 to 150 miles	\$5.00
Zone 3	150 to 300 miles	\$6.00
Zone 4	300 miles over	\$7.00

ADD PREMIUM PAY

- One and one-half (1-1/2) times the applicable straight-time rate for the day, shift, work, equipment and classification shall be paid for all work (including repair work and field survey work) performed on Saturday and before a shift begins and after it ends, except when operating equipment servicing a craft that is receiving double time on commercial building construction, in which case double time shall be paid.
- Overtime. The following rates shall apply on Sundays and holidays and all work before a shift begins and after it ends:
 Saturday Shift Period. On any shift, Saturday shall be the twenty-four-hour period commencing at 12:00 midnight Friday.
 Sunday Shift Period. On any shift, Sunday shall be the twenty-four-hour period commencing at 12:00 midnight Saturday.
- For hours worked in excess of 12 on any such workday, an Employee shall be paid two (2) times the regular straight-time rate of pay for each hour so worked.

RECOGNIZED HOLIDAYS

Holidays. Double the applicable straight-time rate shall be paid for all work (including repair, maintenance and field survey work) performed on Sundays and the following holidays: New Year's Day (January 1); Memorial Day (last Monday in May); Independence Day (July 4); Labor Day (1st Monday in September); Nevada Admission Day (last Friday in October); Thanksgiving Day (4th Thursday in November); the day after Thanksgiving Day; and Christmas Day (December 25). Holidays falling on Sunday shall be observed on the following Monday. Holiday hours shall be reckoned on the same basis as Sunday hours.

JOB DESCRIPTION includes but is not limited to:

- Planning ground surveys designed to establish base lines, elevation and other geodetic measurements;
- Compiling data relevant to the shape, contour, gravitation, location, elevation and dimension of land and land features on or near the surface of the Earth for engineering, map making, mining, land evaluation, construction and other purposes;
- Surveying bodies of water to determine navigable channels and to secure data for construction of breakwaters, piers and other marine structures;
- Computing data necessary for driving and connecting underground passages, underground storage and volume of underground deposits.

Craft: TAPER (Union Rate)

Prevailing wage rates include the base rate as well as all applicable fringes

Taper-Journeyman.....	56.76
Taper-Foreman.....	60.83

ADD ZONE RATE

In addition to: TAPER rates add the applicable amounts per hour Zone Pay shall commence from Maryland Parkway and Charleston Boulevard and shall be paid as follows:

Zone 1	0 to 40 miles	\$0.00
Zone 2	40 to 60 miles	\$2.50
Zone 3	over 60 miles	\$4.25

RECOGNIZED HOLIDAYS

New Year's Day, President's Day, Memorial Day, Independence Day, Labor Day, Veteran's Day, Thanksgiving Day, Day after Thanksgiving Day, Christmas Day. When holiday falls on a Sunday, the Monday following shall be observed as the holiday; holidays falling on Saturday shall be observed on the prior Friday.

ADD PREMIUM PAY

All overtime, except Sundays and holidays, will be time and one-half (1 1/2). Sundays and holidays will be paid double time (2X). Any and all work performed in excess of the regular workday of eight (8) hours, or ten (10) hours if mutually agreed to, and the regular workweek of forty (40) hours shall be considered overtime and shall be paid for at one and one-half (1 1/2) times the regular hourly rate.

JOB DESCRIPTION: Excerpt from Agreement between DC 16 and the independent Drywall Contractors of Northern Nevada

SECTION 1 -- The scope of work covered by this Agreement shall include (but not be limited to) all work operations, including distribution to the point of application, as follows:

- (a) Work or services pertaining to the preparation, spotting, pointing, detailing, flushing, sanding and finishing of interior and/or exterior gypsum, drywall, thin wall, concrete, steel, wood and plaster surfaces, spackling of all surfaces where adhesive materials are used; and all drywall pointing, taping and finishing.
- (b) Work or services pertaining to the application of all finish or flushing materials regardless of method of application or type of surface on which materials are applied, including but not limited to texture and simulated acoustic materials of all types and the application of radiant heat fill and steel fireproofing materials.
- (c) Work or services pertaining to the installation of protective coverings and masking prior to the application of finish materials.
- (d) The operation and care of all taping tools and texturing equipment used in the finishing and texturing of drywall and other surfaces including brushes, rollers, spray texturing equipment, miscellaneous hand, mechanical, and power tools, and the operation and maintenance of compressors required in the finishing and texturing of such surfaces.
- (e) No limitation shall be placed on the work covered by this Agreement by reason of the surface, type of material or purpose for which the materials used are designed or intended.
- (f) The cleanup of all materials and debris occasioned by any job operation at the site of construction, alteration, or repair undertaken whether such operation occurs on the interior or exterior of a building structure.

Craft: TILE SETTER/TERRAZZO WORKER/MARBLE MASON FINISHER (Union Rate)

Prevailing wage rates include the base rate as well as all applicable fringes

Tile Setter/Terrazzo Worker/Marble Mason - Finisher.....	40.32
Tile Setter/Terrazzo Worker/Marble Mason - Finisher Foreman.....	41.57
Tile Setter/Terrazzo Worker/Marble Mason Finisher- General Foremen.....	43.32

ADD PREMIUM PAY

All work in excess of forty (40) hours during the established work week shall be paid at the rate of one and one-half (1-1/2) times the hourly base wage rate in effect.

Employees shall be paid one and one-half (1-1/2) times the hourly wage rate for all hours worked over eight (8) in a single day and double time after ten (10) hours in a single day, Monday through Friday, except recognized holidays.

Daily Overtime Saturdays the first ten (10) hours performed on Saturday shall be paid at one and one-half (1-1/2) times the straight time wage rate.

Daily Overtime Sunday- Employees shall be paid double time on Sundays if forty (40) straight time hours have been worked during the proceeding work week.

Holidays shall be paid double time for hours owed on recognized holidays.

RECOGNIZED HOLIDAYS

New Year's Day, President's Day, Memorial Day, Independence Day, Labor Day, Veteran's Day, Thanksgiving Day, Day after Thanksgiving Day, Christmas Day. Any holiday falling on a Sunday will be observed on Monday.

JOB DESCRIPTION: Excerpt from Agreement between BAC 13 Nevada of the Mountain West Administrative District Council Master Labor Agreement

FINISHER'S WORK:

Finisher's work shall consist of assisting, helping or supporting the tile, marble and terrazzo mechanic by performing their historic and traditional work assignments. required to complete the proper installation of the work covered by Sections 5, 7 and 8 of this Code.

Craft: TILE SETTER/TERRAZZO WORKER/MARBLE MASON (Union Rate)

Prevailing wage rates include the base rate as well as all applicable fringes

Tile Setter - Journeyman.....	50.37
Tile Setter - Foreman.....	51.62 Tile
Setter - General Foreman....	53.37
Terrazzo/Marble Mason - Journeyman	51.87
Terrazzo/Marble Mason - Foreman	53.12
Terrazzo/Marble Mason - General Foreman.....	54.87

ADD ZONE RATE

In addition to TILE SETTER/TERRAZZO WORKER/MARBLE MASON rates add the applicable amounts per hour, calculated based on a road miles of over fifty (50) miles from the Washoe County Courthouse in Reno, Nevada:

Zone 1	0 to 50 miles	\$0.00
Zone 2	50 to 75 miles	\$3.75
Zone 3	Over 70 miles	\$8.13

ADD PREMIUM PAY

All work in excess of forty (40) hours during the established work week shall be paid at the rate of one and one-half (1-1/2) times the hourly base wage rate in effect.

Employees shall be paid one and one-half (1-1/2) times the hourly wage rate for all hours worked over eight (8) in a single day and double time after ten (10) hours in a single day, Monday through Friday, except recognized holidays.

Daily Overtime Saturdays the first ten (10) hours performed on Saturday shall be paid at one and one-half (1-1/2) times the straight time wage rate.

Daily Overtime Sunday- Employees shall be paid double time on Sundays if forty (40) straight time hours have been worked during the proceeding work week.

Holidays shall be paid double time for hours owed on recognized holidays.

RECOGNIZED HOLIDAYS

New Year's Day, President's Day, Memorial Day, Independence Day, Labor Day, Veteran's Day, Thanksgiving Day, Day after Thanksgiving Day, Christmas Day. Any holiday falling on a Sunday will be observed on Monday.

JOB DESCRIPTION: Excerpt from Agreement between BAC 13 Nevada of the Mountain West Administrative District Council Master Labor Agreement

TILE LAYERS' WORK:

Tile laying shall consist of, but not be limited to, the following work procedures and installation of the following materials:

A. The laying, cutting or setting of all tile where used for floors, walls, ceilings, walks, promenade roofs, stair treads, stair risers, facings, hearths, fireplaces, and decorative inserts, together with any marble plinths, thresholds or window stools used in connection with any tile work; also, preparing and setting all concrete, cement, brickwork, or other foundation or materials that may be required to properly set and complete such work; setting or bedding all tiling, stone, marble, composition, glass, mosaic, or other materials forming the facing, hearth or fireplace of a mantel, or the mantel complete, together with setting of all cement, brickwork, or other materials required in connection with the above work; also the slabbing and fabrication of tile mantels, counters and tile panels of every description, and the erection and installation of same; the building, shaping, forming, construction or repairing of all fireplace work, whether in connection with a mantel hearth facing or not, and the setting and preparing of all material, such as cement, plaster, mortar, brickwork, iron work or other materials necessary for the proper and safe construction and completion of such work, except that a mantel made exclusively of brick, marble or stone, shall be conceded to be bricklayers', marble setters' or stonemasons' work, respectively.

B. It will be understood that the word "tile" refers to all burned clay products, as used in the tile industry, either glazed or unglazed, and to all composition materials made in single units up to 15"x20"x2", except quarry tiles larger than 9"x9"x1 1/4", also to mixtures in tile form of cement, plastics and metals that are made for and intended for use as a finished floor surface, whether upon interior or exterior floors, stair treads, promenade roofs, garden walks, interior walls, ceilings, swimming pools, and all places where tile may be used to form a finished surface for practical use, sanitary finish or decorative purposes, for setting all accessories in connection therewith, or for decorative inserts in other materials.

C. All terra cotta called unit tile in sizes of 6"x12" or under, regardless of method of installation, quarry tile 9"x9"x1 1/4" or less; split brick or quarry tile or similar material where the bed is floated or screeded and the joints grouted. Where the work is installed by tile layers, the grouting and cleaning shall be supervised by the mechanic. The bedding, jointing, and pointing of the above materials shall be the work of the craft installing the same. All clay products known as terra cotta tile, unit tile, ceramic veneer and machine-made terra cotta, and like materials in sizes 6"x12" and less regardless of the method of installation. Where the preponderance of materials to be installed comes within the provisions of this Section and when there is also some material in excess of the sizes provided for in this Section, the tile setter shall install all such materials.

D. The preparation, setup, calibration, operation, cleaning, and routine maintenance of any mechanical devices or robotics used to install tile and related materials, or that otherwise assist the tile layer in performing any of the work described in Article II and Code 1 of the IU Constitution, as well as the preparation and ongoing maintenance of the work area to allow proper installation of tile and related materials.

Craft: TRAFFIC BARRIER ERECTOR (Union Rate)

Prevailing wage rates include the base rate as well as all applicable fringes

Traffic Barrier Erector.....48.53

ADD ZONE RATE

In addition to LABORER rates add the applicable amounts per hour, calculated based on a road miles from either the Carson City Courthouse or the Washoe County Courthouse:

Zone 1	0 to 75 miles	\$0.00
Zone 2	75 to 150 miles	\$5.00
Zone 3	150 to 300 miles	\$6.00
Zone 4	300 miles and over	\$7.00

ADD PREMIUM PAY

One and one half (1 ½) the regular straight time hourly rate shall be paid:

1. For all hours worked over eight (8) hours in one day or shift.
2. For any hours worked on Saturday from mid night to midnight.

Double the regular straight time hourly rate shall be paid for all time:

1. For all hours worked over twelve (12) hours in one day or shift.
2. For any hours worked on Sunday from midnight to midnight.
3. For any hours worked on holidays from midnight to midnight.

RECOGNIZED HOLIDAYS

If any of these holidays fall on Sunday, the Monday following shall be considered a Holiday. New Year's Day, President's Day, Memorial Day, Independence Day, Labor Day, Veteran's Day, Thanksgiving Day, Day after Thanksgiving Day, Christmas Day.

JOB DESCRIPTION: Excerpt from Agreement between AGC and LIUNA Local 169

1. Distributing traffic control signs and markers along site in designated pattern;
2. Informing drivers of detour routes through construction sites;

Craft: Truck Driver (Non-Union Rate)

Prevailing wage rates include the base rate as well as all applicable fringes

Dump Trucks (Single or Multiple Units Including Semi's & Double Transfer Units), Dumpcretes and Bulk Cement Spreader

Under 4 yds. (water level).....	32.25
4 yds. & under 8 yds. (water level).....	32.25
8 yds. & under 18 yds. (water level).....	32.25
18 yds. & under 25 yds. (water level)	32.25
25 yds. & under 60 yds. (water level).....	32.25
60 yds. & under 75 yds. (water level)).....	32.25
75 yds. & under 100 yds. (water level)).....	32.25
100 yds. & under 150 yds. (water level)).....	32.25
150 yds. & under 250 yds. (water level)).....	32.25
250 yds. & under 350 yds. (water level)).....	32.25
350 yds. & over (water level).....	32.25

Transit Mix

Under 8 yds.....	32.25
Under 8 yds & including 12 yds.....	32.25
Over 12 yds.....	32.25

Transit Mix (Using Boom)

Transit mix with boom shall receive 16 cents per hour above the appropriate yardage classification rate of pay when such boom is used.....	32.25
--	-------

Water & Jetting Trucks

Up to 2,500 gallons.....	32.25
Up to 2,500 gallons & over.....	32.25
DW 20's & 21's & other similar Cat type, Terry Cobra LeTourneau pulls, Tournerocker, Euclid, & similar type equipment when pulling Aqua/Pak, Water Tank Trailers, & Fuel, and/or Grease Tank Trailer, or other miscellaneous Trailers, (except as defined under "Dump Trucks")	
Heavy Duty Transport (High Bed).....	32.25
Heavy Duty Transport(Gooseneck low bed).....	32.25
Tiltbed or Flatbed Pull Trailers.. ..	32.25
Bootman, Comb. Bootman & Road Oiler.....	32.25
Flat Rack (2 or 3 axle unit).....	32.25

Bus & Manhaul Drivers

Up to 18,000 lbs. (single unit).....	32.25
18,000 lbs. and over	32.25
Warehousemen Spotter	32.25

Winch Truck & "A" Frame Drivers

Up to 18,000 lbs.	32.25
18,000 lbs. and over.....	32.25
Warehousemen Spotter.....	32.25
Warehouse Clerk.....	32.25
Tire Repairmen.....	32.25
Truck Repairmen.....	32.25
Pick Up Truck & Pilot Cars (Jobsite)	32.25
Pick Up Truck & Pilot Cars (Over the road)	32.25
Truck Oil Greaser.....	32.25
Fuel Truck Driver.....	32.25
Fuel Man & Fuel Island Man.....	32.25
Oil Tanker.....	32.25

Oil Tanker with Pup.....	32.25
Foreman.....	32.25

TRUCK DRIVER

Includes but is not limited to:

Driving a tractor trailer combination or a truck to transport goods or materials at the site of a public work or between sites of a public work. (Also, see descriptions listed with Truck Driver rates, if any.)

Craft: WELL DRILLER (Non-Union Rate)

Prevailing wage rates include the base rate as well as all applicable fringes

Well Driller.....60.78

JOB DESCRIPTION

1. Setting, operating or tending to portable drilling rig machinery and related equipment to drill wells;
2. Extending stabilizing jackscrews to support and level a drilling rig;
3. Installing water well pumps;
4. Drillings wells for industrial water supplies, irrigation water supplies or water supplies for any other purpose; dewatering or other similar purposes; exploration; hole drilling for geologic and hydrologic information; and core drilling for geologic information.

GROUP CLASSIFICATIONS

LABORER, includes but is not limited to:

Group 1

- All cleanup work of debris, grounds, and building including windows and tile
- Dumpmen or Spotter (other than asphalt)
- Handling and Servicing of Flares, Watchmen
- General Laborer
- Guideposts and Highway Signs
- Guardrail Erection and Dismantling
- Limber, Brushloader and Piler
- Pavement Marking and Highway Striping
- Traffic Barrier Erector
- Tending to portable space heaters
- Profilograph work all types manual, self propelled or carts
- Gabion basket, building, handling, installation and rigging
- Dry set paver work
- Traffic Barrier Erector

Group 2

- Choker setter or Rigger (clearing work only) Pittsburgh
- Chipper and similar type brush shredders
- Concrete worker (wet or dry) all concrete work not listed in Group 3 included but not limited to: concrete forms stripping, handling, cleaning, oiling and moving to the next point of installation.
- Crusher or Grizzly Tender
- Greasing Dowels
- Guinea Chaser (Stakemen)
- Panel Forms (wood or metal) handling, cleaning and stripping of Loading and unloading, (Carrying and handling of all rods and material for use in reinforcing concrete
- Railroad Trackmen (maintenance, repair or builders)
- Sloper
- Semi-Skilled Wrecker (salvaging of building materials other than those listed in Group 3)
- Waterproofing work
- Epoxy rebar/dowels and anchoring dowel baskets
- Placement pouring of concrete including any epoxy resin or similar materials, rodding, spreading and tamping concrete, brooming or brushing, hand application of curing compounds, applying topping (wet or dry) colors or grits, and exposed finishes for architectural work
- Concrete patching, dry packing, chipping, stoning, and grouting
- Concrete cold weather/rain protection and curing
- Placement /anchoring of all earth stabilization/filters fabrics,
- Mechanically stabilized Earth (MSE) and Keystone type retaining walls rigging, placing , aligning, backfilling and installation of dead men and any stabilization components

Group 3

- Asphalt Workers (Ironers, Shovelers, Cutting Machine)
- Buggymobile
- Chainsaw, Faller, Logloader and Bucker

- Compactor (all types)
- Concrete Mixer under 1/2 yard
- Concrete Pan Work (Breadpan type), handling, cleaning\stripping
- Concrete Saw, Chipping, Grinding, Sanding, Vibrator
- Cribbing, Shoring, Lagging, Trench Jacking, Hand-Guided Lagging Hammer
- Curbing or Divider machine
- Curb Setter (precast or cut)
- Ditching Machine (hand-guided)
- Drillers Helper, Chuck Tender
- Fence erector including safety, chain link, turtle, field and barbe wire fencing
- Form Raiser, Slip Forms
- Grouting of Concrete Walls, Windows and Door Jams
- Headerboardmen
- Jackhammer, Pavement Breaker, Air Spade
- Mastic Worker (wet or dry)
- Pipewrapper, Kettlemen, Potmen, and men applying asphalt, creosote and similar type materials
- All Power Tools (air, gas, or electric), Post Driver
- Riprap-Stonepaver and RockSlinger, including placing of sack concrete wet or dry
Rototiller
- Rigging and Signaling in connection with Laborers' work
- Sandblaster, Potmen, Gunmen or Nozzlemen water blasting not covered in group 5A
- Vibra-screed
- All demolition and wrecking work including but not limited t any torch work cutting, burning, plasma are, dust control, and salvaging (removing and salvaging of all materials, windows, doors, plumbing, and electrical fixtures) and use of customary tools and equipment for demolition and wrecking
- All underpinning foundation work, digging and underpinning pits, removal of debris with tuggers or other methods, cutting, handling and installing all shoring boards and lagging boards used for underpinning and foundation work, placement and tying of steel reinforcing for underpinning piers, all tiebacks and soil nail work drilling and grouting, all soldier beam work and us of customary tools and equipment for underpinning foundation work

Group 3A

- Concrete Specialist
- Setting screeds
- Screed pins
- Curb forms and curb and gutter forms,
- Using Darby and push floats,
- Hand trowels or hand floating
- Marking edging
- Using base cove or step tools
- Spreading and finishing gypsum
- Concrete grinding machines (the terms does not include Rotomill machines for highway overlay grinding)
- Troweling machines,
- Floating machines
- Finishing of epoxy or resin materials,
- Operation of skill saw
- Laser Screed
- Laser Level

- Curb and Slipform machines,
- Stamps or other means or texturing,
- Any new devices which are beneficial to the construction of or with concrete or related products.

Group 4

- Burning and Welding in connection with Laborers' work
- Joy Drill Model TWM-2A, Gardner Denver Model DN143 and similar type drills (in accordance with Memorandum of Understanding between Laborers and Operating Engineers dated at Miami, Florida, Feb. 3, 1954) and Track Drillers, Diamond Core Drillers, Wagon Drillers, Mechanical Drillers on Multiple Units
- High scalers including but not limited to laying, anchoring, pinning, cabling and stretching of any rock fall netting, mesh or wire fabric and use of customary tools and equipment for high scaling
- Concrete pump operator
- Heavy Duty Vibrator with Stinger 5" diameter or over
- Pipelayer, Caulker and Bander
- Pipelayer-waterline, Sewerline, Gasoline, Conduit and all other types of composition for any purpose buried under ground outside of building including, stringing, trench shoring, backfilling sanding, caution taping, all walk behind equipment and spotting
- Laborer work in connection with micro tunneling, directional drilling and pipe-jacking
- Cathodic protection, grounding for pipe work
- Cleaning of Utility Lines
- Slip Lining of Utility Lines (including operation of Equipment)
- TV Monitoring and Grouting of Utility Lines
- Asphalt Rakers and Asphalt dump Man
- All mechanical and pressurized pipe work, including the installation of pipe above and below ground, cathodic protection, bolt up, and support installation in connection to water conveyance, c

Group 4A

- Foreman

Group 5

- Construction Specialists
- Blasters and Powdermen, all work of loading, placing, and blasting of all powder and explosives of any type, regardless of method used for such loading and placing
- Asbestos removal
- Lead abatement
- Hazardous waste
- Material removal

Group 5A

- Pavement Marking and Highway Striping
- Pavement Marking and Highway Striping Foreman
- Pavement Marking and Highway Striping work includes but is not limited to: All work by any method performed in connection with the permanent or temporary application and installation of pavement marking of any kind, brand, type or style on parking lots, airfields, highways, streets and other such surfaces and all work performed in connection with removal of pavement.

Group 6

- Gunit Foremen, Nozzlemen, Rodmen, Gunmen, Materialmen, Reboundmen

- Tunnel and shaft workers/miners and use of customary tools and equipment for tunnel and mine work All worked performed in a compressed air tunnel shaft or chamber including the use of hand, power tools or equipment as necessary in connection with compressed air work
-

OPERATING ENGINEER, includes but is not limited to:

Group 1

- Engineer Assistant

Group 1A

- Oiler (Construction)
- Partsman

Group 2

- Compressor Operator
- Material Loader and/or Conveyor Operator (handling building materials)
- Pump Operator

Group 3

- Bobcat or similar loader, 1/4 cu. yd. or less
- Concrete Curing Machines (streets, highways, airports, canals)
- Conveyor Belt Operator (tunnel)
- Forklift (under 20)
- Engineer Generating Plant (500 K.W.)
- Mixer Box Operator (concrete plant)
- Motorman
- Rodman/Chainman
- Rotomist Operator
- Oiler (truck crane)

Group 4

- Concrete Mixer Operator, Skip type
- Dinky Operator
- Forklift (20' or over) or Lumber Stacker
- Ross Carrier
- Skip Loader Operator (under one (1) cu. yd.)
- Tie Spacer

Group 5

- Concrete Mixers (over one (1) cu. yd.)
- Concrete Pumps or Pumpcrete Guns
- Elevator and Material Hoist (one (1) drum)
- Groundman for Asphalt Milling and similar

Group 6

- Auger type drilling equipment up to and including 30 ft. depth digging capacity M.R.C.
- Boom Truck or Dual-Purpose a-Frame Truck
- B.L.H. Lima Road Pactor or similar
- Chip Box Spreader (Flaherty type or similar)
- Concrete Batch Plant (wet or dry)
- Concrete Saws (highways, streets, airports, canals)
- Locomotives (over thirty (30) tons)
- Maginnis International Full Slab Vibrator (airports, highways, canals and warehouses)
- Mechanical Finishers (concrete) (Clary, Johnson, Bidwell Bridge Deck or similar types)

- Mechanical Burn, Curb and/or Curb and Gutter Machine (concrete or asphalt)
- Pavement Breaker, Truck Mounted, with compressor combination
- Pavement Breaker or Tamper (with or without compressor combination)
- Power Jumbo Operator (setting slip-forms, etc., in tunnels)
- Roller Operator (except asphalt)
- Self-Propelled Tape Machine
- Self-Propelled Compactor (single engine)
- Self-Propelled Power Sweeper Operator
- Slip-Form Pump (power-driven by hydraulic, electric, air, gas, etc. lifting device for concrete forms)
- Small Rubber-Tired Tractors
- Snooper Crane, Paxton-Mitchell or similar
- Stationary Pipe Wrapping, Cleaning and Bending Machine Operator

Group 7

- Auger type drilling equipment over 30 ft. depth digging capacity M.R.C.
- Compressor (over 2)
- Concrete Conveyor or Concrete Pump, truck or equipment mounted (any assistance required shall be performed by an Assistant to Engineer) Boom length to apply Concrete Conveyor, Building Site
- Drilling and Boring Machine, vertical and horizontal (not to apply to waterliners, wagon drills or jack hammers)
- Crusher Plant Engineer
- Generators
- Instrument Man
- Kolman Loader
- Material Hoist (two (2) or more drums)
- Mine or Shaft Hoist
- Pipe Bending Machines (pipeline only)
- Pipe Cleaning Machines (tractor-propelled and supported)
- Pipe Wrapping Machines (tractor-propelled and supported)
- Portable Crushing and Screening Plants
- Post Driller And/or Driver
- Pumps (over 2)
- Screedman (except asphaltic or concrete paving)
- Self-Propelled Boom-Type Lifting Device (center mount) (on ten (10) ton capacity or less)
- Slusher Operator
- Soil Tester (Certified)
- Soils and Materials Tester
- Surface Heater and Planer Operator
- Trenching Machine (maximum digging capacity three (3) ft. depth) (Any assistance in the operation, if needed, shall be performed by an Assistant to Engineer)
- Truck-Type Loader
- Welding Machines (gasoline or diesel)

Group 8

- Articulated on-Site Dump Trucks
- Asphalt Plant Engineer
- Asphalt Milling Machine

- Cast-In-Place Pipe-Laying Machine
- Combination Slusher and Motor Operator
- Concrete Batch Plant (multiple units)
- Dozer Operator
- Drill Doctor
- Elevating Grader Operator
- Stiff Frame Off Road Haul Trucks
- Grooving and Grinding Machine (highways)
- Ken Seal Operator
- Marination Plant
- Loader (up to and including two and one-half (2 1/2) cu. yds)
- Mechanical Finishers or Spreader Machine (asphalt, Barber-Greene or similar)
- Shuttle Buggy
- Mechanical Trench Shield
- Mixermobile
- Push Cats
- Road Oil Mixing Machine Operator Wood-Mixer (and other similar Pugmill equipment)
- Roller Operator (asphalt)
- Rubber-Tired Earthmoving Equipment (up to and including thirty-five (35) cu. yds. "struck " M.R.C., Euclids, T-Pulls, DW10, 20, 21 and similar)
- Water Pull
- Screedman (Barber-Greene and similar) (asphaltic or concrete paving)
- Self-Propelled Compactors with Dozer; Hyster 450, Cat 825 or similar
- Sheepfoot
- Small Tractor (with boom)
- Soil Stabilizer (P & H or equal)
- Timber Skidder (rubber-tired) or similar equipment
- Track Loader
- Tractor-Drawn Scraper
- Tractor Operator
- Tractor-Mounted Compressor Drill Combination
- Trenching Machine Operator (over three (3) feet depth)
- Tri-Batch Paver
- Tunnel Badger or Tunnel Boring Machine Operator
- Tunnel Mole Boring Machine
- Vermeer T-600b Rock Cutter
- Vacuum Truck(excludes trailer mounted vaccums)

Group 9

- Chicago Boom
- Combination Backhoe and Loader (up to and including 3/8 cu. yd.)
- Combination Mixer and Compressor (gunite)
- Heavy Duty Repairman and/or Welder
- Lull Hi-Lift (twenty (20) feet or over)
- Mucking Machine
- Sub-Grader (Gurries or other types)
- Tractor (with Boom) (D6 or larger)
- Track-Laying-Type Earthmoving Machine (single engine with tandem scrapers)

Group 10

- Boom-Type Backfilling Machine
- Bridge Crane
- Cary-Lift or similar
- Chemical Grouting Machine
- Chief of Party
- Derricks (two (2) Group 10 Operators required when swing engine remote from hoist)
- Derrick Barges (except excavation work)
- Euclid Loader and similar types
- Heavy Duty Repairman
- Heavy Duty Rotary Drill Rigs
- Lift-Slab (Vagtborg and similar types)
- Loader (over two and one-half (2 1/2 cu. yds. up to and including four (4) cu. yds.)
- Locomotive (over one hundred (100) tons, single or multiple units)
- Multiple-Engine Earthmoving Machines (Euclid Dozers, etc.)
- Pre-Stress Wire Wrapping Machine
- Rubber-Tired Scraper, Self-Loading
- Single-Engine Scraper (over thirty-five (35) cu. yds.)
- Shuttle Car (Reclaim Station)
- Train Loading Station
- Trenching Machine multi-engine with sloping attachments (Jefco or similar)
- Vacuum Cooling Plant
- Whirley Crane (up to and including twenty-five (25) tons)

Group 10A

- Backhoe-Hydraulic (up to and including one (1) cu. yd.)
- Backhoe (up to and including one (1) cu. yd.) (Cable)
- CMI Dual Lane Auto-Grader SP30 or similar type
- Cranes (not over twenty-five (25) tons) (hammerhead and gantry)
- Finish Blade
- Gradalls (up to and including one (1) cu. yd.)
- Motor Patrol Operator
- Power Shovels, Clamshells, Draglines, Cranes (up to and including one (1) cu. yd.)
- Rubber-Tired Scraper, Self-Loading (twin engine)
- Self-Propelled Boom-Type Lifting Device, center mount (over 10 tons up to and including 25 tons)

Group 11

- Automatic Asphalt or Concrete Slip-Form Paver
- Automatic Railroad Car Dumper
- Canal Trimmer
- Cary Lift, Campbell or similar type
- Cranes (over twenty-five (25) tons)
- Euclid Loader when controlled from the Pullcat
- Finish Blade
- Gradesetter, Grade Checker
- Highline Cableway Operator
- Loader (over four (4) cu. yds. up to and including twelve (12) cu. yds.)
- Multi-Engine Earthmoving Equipment (up to and including seventy-five (75) cu. yds. struck m.r.c.)
- Multi-Engine Scrapers (when used to Push Pull)

- Power Shovels, Clamshells, Draglines, Backhoes Gradalls (over one (1) cu. yd. and up to and including seven (7) cu. yds. m.r.c.)
- Self-Propelled Boom-Type Lifting Device (center mount) (over 25 tons m.r.c.)
- Self-Propelled Compactor (with multiple-propulsion power units)
- Single-Engine Rubber-Tired Earthmoving Machine, with Tandem Scraper
- Slip-Form Paver (concrete or asphalt)
- Tandem Cats and Scraper
- Tower Crane Mobile (including Rail Mount)
- Truck Mounted Hydraulic Crane when remote control equipped (over 10 tons up to and including 25 tons)
- Universal Liebherr and Tower Cranes (and similar types)
- Wheel Excavator (up to and including seven hundred fifty (750) cu. yds. per hour)
- Whirley Cranes (over twenty-five (25) tons)

Group 11A

- Band Wagons (in conjunction with Wheel Excavators)
- Operator of Helicopter (when used in construction work)
- Loader (over twelve (12) cu. yds.)
- Multi-Engine Earthmoving Equipment (over seventy-five (75) cu. yds. "struck" m.r.c.)
- Power Shovels, Clamshells, Draglines, Backhoes, and Gradalls (over seven (7) cu. yds. m.r.c.)
- Remote-Controlled Earth Moving Equipment
- Wheel Excavator (over seven hundred fifty (750) cu. yds. per hour)

Group 11B

- Holland Loader or similar or Loader (over 18 cu. yds.)

OPERATING ENGINEERS - Steel Fabricator & Erector

Group 1

- Cranes over 100 tons
- Derrick over 100 tons
- Self-Propelled Boom Type Lifting Devices over 100 tons

Group 2

- Cranes over 45 tons up to and including 100 tons
- Derrick, 100 tons and under
- Self-Propelled Boom Type Lifting Device, over 45 tons
- Tower Crane

Group 3

- Cranes, 45 tons and under
- Self-Propelled Boom Type Lifting Device, 45 tons and under

Group 4

- Chicago Boom
- Forklift, 10 tons and over
- 59
- Heavy Duty Repairman/Welder

Group 5

- Boom Cat
-

OPERATING ENGINEER -PILEDRIIVER

Group 1

- Derrick Barge Pedestal mounted over 100 tons
- Clamshells over 7 cu. yds.
- Self-Propelled Boom Type Lifting Device, over 100 tons
- Truck Crane or Crawler, land or barge mounted over 100 tons

Group 2

- Derrick Barge Pedestal mounted 45 tons up to and including 100 tons
- Clamshells up to and including 7 cu. yds.
- Self-Propelled Boom Type Lifting Device over 45 tons
- Truck Crane or Crawler, land or barge mounted, over 45 tons up to and including 100 tons

Group 3

- Derrick Barge Pedestal mounted under 45 tons
- Self-Propelled Boom Type Lifting Device 45 tons and under
- Skid/Scow Piledriver, any tonnage
- Truck Crane or Crawler, land or barge mounted 45 tons and under

Group 4

- Assistant Operator in lieu of Assistant to Engineer
- Forklift, 10 tons and over
- Heavy Duty Repairman/Welder

Group 5

No current classification

Group 6

- Deck Engineer

Group 7

No current classification

Group 8

- Deckhand
 - Fireman
-

TABLE OF CONTENTS
Technical Specifications

<u>Section</u>	<u>Description</u>	<u>Pages</u>
09930	Protective Epoxy Polymer Lining System.....	14

SECTION 09930

PROTECTIVE EPOXY POLYMER LINING SYSTEM FOR WASTEWATER STRUCTURES

ARTICLE 1 - GENERAL

1.01 PURPOSE

The purpose of this specification is to establish methods, materials, standard, and procedures for coating manholes and wetwells.

1.02 SCOPE OF WORK

- A. Work is on an existing concrete manhole and steel wetwell located at 835 Lakeshore Blvd. Incline Village, NV 89451.
- B. The CONTRACTOR shall furnish all supervision, labor, tools, materials, equipment, scaffolding, and incidentals required to install a protective coating system for the surfaces listed herein and not otherwise excluded. Work to be accomplished includes field application of the protective lining system to interior surfaces, including surface preparation, handling of hazardous wastes, supply of inspection instruments, and other work necessary to accomplish the approved end result of totally protected and usable structures, including all attachments, accessories and appurtenances, generally as follows:
 - 1. Remove all existing coating by abrasive blast cleaning, pressure washing and/or sanding, or other method approved by the OWNER.
 - 2. Apply the intermediate and finish coats to all manhole and wetwell surfaces.
 - 3. Where not otherwise shown, the extent of the protective lining shall be located 1) interior walls of structures and/or manholes to be protected, and 2) interior surfaces of structures such as floors, lids and top decks as shown on drawings and/or noted in written specifications
 - 4. Types of protective lining system components for the corrosion protection work required, including surface treatment of prepared surfaces prior to coating application, shall include, but are not necessarily limited to, the following:
 - a. Epoxy-modified cement filler compound
 - b. Corrosion-resistant, spray-applied Protective Epoxy Polymer Lining
 - c. Miscellaneous materials
- C. Lead Remediation.
 - 1. *Contractor's Responsibility:* The CONTRACTOR will be responsible for all necessary means and methods to contain painted blast residue. The CONTRACTOR shall be responsible for storage, transport and final disposal of all spent blast materials and residue in accordance with local, State and Federal regulations. The CONTRACTOR shall plug vents and take other such measures as are required while blasting and vacuuming tanks to prevent migration of blasted paint and blast residue, etc. into the environment. CONTRACTOR shall

supply copies of documents to OWNER verifying proper handling, testing and disposal of lead based paint debris.

2. "Attachment A" contains the lead report.

D. Coordination

1. Remove all chemicals, films, laitance, compounds and other materials from substrates to receive the Work of this Section, as may be required by the protective lining manufacturer at no additional expense to OWNER.
2. If severely corroded or damaged steel is discovered during the course of cleaning or painting operations, repair of severely corroded or damaged areas and other mechanical repairs may be required during project.
3. The CONTRACTOR shall notify OWNER and submit change order documentation, as appropriate.
4. A time extension will be issued should repairs preclude cleaning and/or paint application. No additional time will be granted to permit the CONTRACTOR to complete other projects prior to this project.

E. The following items will not be painted:

1. Any code-required labels, such as Underwriters' Laboratories and Factory Mutual, or any equipment identification, performance rating, name, or nomenclature plates
2. Any moving parts of operating units, mechanical, and electrical parts unless otherwise indicated
3. Stainless steel angles, tube, pipe, etc.
4. Products with polished chrome, aluminum, nickel, or stainless steel finish
5. Flexible couplings, lubricated bearing surfaces, insulation, and metal and plastic pipe interiors
6. Finish hardware

F. Permits, etc. The CONTRACTOR will obtain, at its own expense, all permits, licenses, and inspections, and shall comply with all laws, codes, ordinances, rules and regulations promulgated by authorities having jurisdiction which may bear on the work, including Federal Public Law 91-596 Occupational Safety and Health Act of 1970. Abrasives shall meet the requirements of the Washoe County Department of Health, Air Quality Division. The CONTRACTOR is responsible for obtaining an air quality permit from the Washoe County Department of Health, Air Quality Division and any other permits that may be required to perform the work.

1.02 REFERENCE SPECIFICATIONS AND STANDARDS

- A. Without limiting the general aspects or other requirements of this specification, work and equipment shall conform to applicable requirements of municipal, state, and federal codes, laws, and ordinances governing the work, Steel Structures Painting Council, American Water Works Association, Society of Protective Coatings, National Association of Corrosion Engineers, International Concrete Repair Institute, American Society for Testing and Materials, American Concrete Institute, and manufacturer's printed instructions, subject to Owner's approval.
- B. The Owner's decision shall be final as to interpretation and/or conflict between any of the referenced codes, laws, ordinances, specifications, and standards contained herein.

1.03 SUBMITTALS:

- A. Shop Drawings: Submit for approval the following:
 - 1. Copies of manufacturer's technical data sheets complete with installation instructions for protective lining system required.
 - 2. Maintenance Manual: Copies of manufacturer's written instructions for recommended maintenance practices. Include the following information:
 - a. Product name and number.
 - b. Name, address and telephone number of manufacturer and local distributor or representative.
 - c. Detailed procedures for routine maintenance and cleaning.
 - d. Detailed procedures for repairs.
 - 3. Test Reports: Verification from protective lining system manufacturer that all testing for physical properties has been performed in strict accordance with referenced ASTM standards.
- B. Certificates: Submit manufacturer's certifications that materials have been approved for the installation conditions shown on the Drawings and as specified herein. Submit manufacturer's Materials Warranty certificate.

1.04 CONTRACTOR

- A. The CONTRACTOR shall be a licensed Painting Contractor in the State of Nevada. Contractor shall have a minimum of five (5) years (recent) practical experience and successful history in the application of similar products to surfaces of concrete and steel wastewater structures.
- B. Applicator Qualifications:
 - 1. Engage a single surface preparation and coating installation applicator specialist (APPLICATOR) with specific experience in the application of protective epoxy lining systems, and who is approved by the protective lining manufacturer.

2. The APPLICATOR shall be trained and approved by the protective lining materials manufacturer.

1.05 HOURS OF WORK

- A. The Contractor's activities shall be confined to between the hours of 8:00 a.m. and 6:30 p.m., Monday through Friday, excluding Federal, State, or Local holidays. Deviation from these hours will not be permitted without the prior consent of the OWNER, except in emergencies involving immediate hazard to persons or property.
- B. Inspections requested by or made necessary as a result of actions by the CONTRACTOR on Saturdays, Sundays, or holidays must be scheduled and approved by the OWNER and paid for by the CONTRACTOR at the prevailing rate for overtime or holiday work.

1.06 PRE-JOB CONFERENCE

- A. Approximately one week prior to start of project, a Pre-Job Conference shall be scheduled between representatives of the OWNER and CONTRACTOR. The sequence of work will be discussed and will be mutually agreed upon to assure that the work is accomplished and completed as stated in the Contract, and to allow for inspection and operations flexibility by OWNER. A list of labor, material, and equipment rates for additional work will be established and maintained throughout the project. The CONTRACTOR shall furnish a complete set of submittal data for use and approval by the Owner.

1.07 QUALITY ASSURANCE

- A. General. Quality assurance procedures and practices shall be utilized to monitor all phases of surface preparation, application, and inspection throughout the duration of the project. Refer to Section 1.04 herein, for required product-related application qualifications.
- B. Performance Criteria: The surfaces to receive the protective lining system shall be capable of withstanding, under constant exposure, raw wastewater and withstand attack from hydrogen sulfide and organic acids generated by microbial sources, with no adverse effects. Products capable of only intermittent exposure resistance are not acceptable.
- C. Source Quality Control: Provide each component of protective lining system produced by a single manufacturer, including recommended underlayment, fillers, repair products, base coat and top coat materials.
- D. Reference Standards: Comply with applicable provisions and recommendations of the following except as otherwise shown or specified.
 1. As defined in Part 2 – Products
- E. Statement of Application: Upon completion of the Work under this Section submit a statement to ENGINEER, signed by the protective lining system APPLICATOR stating that the installed protective lining system complies with the requirements of

the Specifications, and that the installation and materials comply with the manufacturer's printed recommendations related to the condition of installation and use.

- F. Corrosion-resistant, spray-applied Protective Epoxy Polymer Lining specified as manufactured by Sauereisen, Pittsburgh, PA (412) 963-0303. Request for material substitutions to the specified products shall be made in writing to the ENGINEER 15 days prior the bid date and no product substitutions or requests for such will be reviewed or accepted after this date. In accordance with these requirements bids must be based on ENGINEER approved products only.
- G. Application Conditions.
 - 1. Environmental Requirements: Maintain substrate temperature and air temperature before, during and after installation in accordance with protective lining manufacturer's written recommendations and instructions.
 - 2. Provide adequate ventilation during application and curing periods.
- H. The CONTRACTOR shall provide, at his own expense, all necessary power required for his operations under this contract.

1.08 SAFETY AND HEALTH REQUIREMENTS

- A. General. Ventilation, electrical grounding, and care in handling paints, solvents and equipment are important safety precautions during painting projects. CONTRACTOR shall conform with safety requirements set forth by regulatory agencies applicable to the construction industry and manufacturer's printed instructions and appropriate technical bulletins and manuals. The CONTRACTOR shall provide and require use of personal protective life-saving equipment for persons working in or about the project site.
- B. Grounding. Spray and air hoses shall be grounded to prevent accumulation of charges of static electricity.
- C. Illumination. Spark-proof artificial lighting shall be provided for all work in contained spaces. Light bulbs shall be guarded to prevent breakage. Lighting fixtures and flexible cords shall comply with the requirements of NFPA 70 "National Electric Code" for the atmosphere in which they will be used. Whenever required by OWNER, the CONTRACTOR shall provide additional illumination and necessary supports to cover all areas to be inspected. The level of illumination for inspection purposes shall be determined by the OWNER.

1.09 DELIVERY, HANDLING, AND STORAGE

- A. Delivery of Materials:
 - 1. Deliver material in manufacturer's original unopened and undamaged packages.
 - 2. Clearly identify manufacturer, brand name, contents and stock number on each package.

- 3. Packages showing indications of damage that may affect condition of contents are not acceptable.
- B. All containers shall be handled and stored in such a manner as to prevent damage or loss of labels or containers.
- C. Used rags shall be removed from the job site daily, and every precaution taken against spontaneous combustion.

1.10 WARRANTY

- A. Protective Lining manufacturer shall warranty its products as free from material defects for a minimum period of one (1) year. Provide associated Warranty Certificate.
- B. APPLICATOR shall warrant the installed protective lining system as free from material and workmanship defects for a minimum period of three (3) years.

ARTICLE 2 - PRODUCTS

2.01 MATERIALS

- A. The Corrosion-resistant, spray-applied Protective Epoxy Polymer Lining shall be a two-component system, including:
 - 1. Cementitious Underlayment when needed and recommended by the Applicator to fill voids and irregularities and to provide a properly prepared surface for the epoxy lining.
 - 2. Epoxy lining to provide abrasion and chemical resistance against physical and chemical attack phenomena typically associated with municipal wastewater service conditions.
 - 3. CONTRACTOR shall provide all accessory components such as sealants, hardeners or other compounds as recommended by the manufacturer for maximum protective coating adherence to substrate, and long-term service performance.
- B. Cementitious Underlayment:
 - 1. Filler Compound shall be a cementitious formulation specifically designed to fill voids, irregularities and air pockets in concrete surfaces. The filler compound shall provide a smooth surface for the application of epoxy monolithic protective coatings. Filler compound shall be confirmed by the manufacturer as compatible with the protective coating.
 - 2. Corrosion-resistant, spray-applied Protective Epoxy Polymer Lining:

Properties	Sewergard No. 210X-HB
Adhesion (ASTM D4541)	Concrete Failure
Bond strength to concrete (ASTM D7234)	Concrete failure
Compressive strength (ASTM D695)	16,000 psi
Components	2 parts
Flexural Strength (ASTM D790) @ 28 days	8,000 psi

Maximum service temperature (Dry)	150°F (65°C)
Mix Ratio (By Volume)	1 Part A-(Hardener) : 3 Parts B-(Resin)
Modulus of elasticity (ASTM D790)	7 x 10 ⁶ psi
Permeability (ASTM E96)	8.06 x 10 ⁻⁹
Shore D (ASTM D2240)	89
Tensile Strength @ 7 days (ASTM D638)	4,500 psi

- C. Product and Manufacturer: Provide one of the following:
1. Sauereisen, Pittsburgh, PA (412) 963-0303.
 2. Or equal in accordance with section 1.07 of this specification.

ARTICLE 3 - EXECUTION

3.01 INSPECTION

- A. The APPLICATOR shall examine the areas and conditions under which protective lining Work is to be performed and notify ENGINEER in writing of conditions detrimental to the proper and timely completion of the Work. Do not proceed with the Work until unsatisfactory conditions have been corrected in a manner acceptable to ENGINEER.
- B. Commencement of the Work of this Section shall indicate that the substrate and other conditions of installation are acceptable to the APPLICATOR and the ENGINEER and will produce a finished product meeting the requirements of the Specifications. All defects resulting from such accepted conditions shall be corrected by APPLICATOR at his own expense.

3.02 SURFACE PREPARATION

- A. Existing Concrete Application - Existing concrete structures to receive protective lining system must be capable of withstanding imposed loads. All oil, grease and chemical contaminants must be removed from the surface of the concrete. All surfaces must be firm, free of damaged or contaminated concrete, laitance, form release agents, and standing water and they must be structurally sound as determined by ENGINEER. Suitable surface preparation methods include shot blasting, abrasive Blasting, or hydro-blasting. Surface preparation procedures shall be in accordance with ICRI Guideline No. 03732. Surface preparation requirement is to expose aggregate and obtain a uniform surface texture resembling an ICRI CSP # 4-6 comparators.
- B. Allow any new concrete to cure for 28 days before protective lining system is installed, unless otherwise recommended by the APPLICATOR or protective lining systems manufacturer.
- C. Concrete surfaces that have been resurfaced must be allowed to cure in accordance with protective lining manufacturer's recommendations prior to application of protective epoxy lining system.

- D. Level or grind concrete substrates to protective lining system manufacturer's recommended tolerances to produce a uniform surface profile, including removal of all sharp edges, ridges or depressions.
- E. Stopping Active Leaks: After surface cleaning and preparation, any visible leaks shall be reported to the ENGINEER. Any minor leaks not requiring other repairs by the ENGINEER must be sealed prior to proceeding with protective lining system installation.
- F. New Concrete Application – All voids, holes and depressions shall be filled with epoxy based filler compound material (section 2.1.B.1), re-establishing plan finished grades and surface profiles. The latest revision of the following surface preparation specifications of the Steel Structures Painting Council shall form a portion of this specification. (Note: An element of surface area is defined as any given square inch of surface.)
- G. Metal Application - Abrasive blast to a minimum 2.5 mil profile employing SSPC-SP5/NACE 1. White Metal Blast for immersion and SSPC-SP10/NACE 2, Near White Metal Blast for other service conditions. All welds must be continuous, free of flux and have a smooth rounded radius without any sharp edges or ground flat in accordance with SSPC/NACE Standard Practices.

3.03 APPLICATION

- A. Application in direct sunlight and/or with rising surface temperatures is not recommended, as this may result in blistering of the materials due to expansion of entrapped air or moisture (out-gassing) in the concrete substrates. In such cases, it will be necessary to postpone the application until later in the day when the temperature of the substrate is falling. Concrete surfaces that have been in direct sunlight must be shaded for at least 24 hours prior to application and remain shaded until the initial set has taken place. Consult protective lining system manufacturer for application schedule guidelines specific to temperature conditions and possible sealer application recommendations to reduce out-gassing.
- B. Filler Compound shall be a cementitious formulation specifically designed to fill voids, irregularities and air pockets in concrete surfaces. The filler compound shall provide a smooth surface for the application of epoxy monolithic protective coatings. Filler compound shall be confirmed by the manufacturer as compatible with the protective coating.
- C. Corrosion-resistant, spray-applied Protective Epoxy Polymer Lining – shall be applied and cured on the properly prepared surface in accordance with protective lining system manufacturer's written guidelines as outlined in product technical data sheets.
 - 1. Epoxy lining shall be applied to a thickness of 125 mils. Application method and equipment shall be approved by the APPLICATOR and shall be in accordance with the protective lining system manufacturer's recommendations.
- D. Expansion and construction joints shall be formed and filled as recommended by the protective lining system manufacturer.

- E. High Voltage Spark Testing. Installed protective epoxy lining shall be tested for pinholes after a minimum 24-hour cure at a temperature of 70°F. Pinhole testing shall be accomplished in accordance with ASTM D-4787, using a Tinker Razor Holiday Detector, San Gabriel, CA, Model AP/W, or an approved equal device. Test voltage of 100 volts/mil of coating thickness shall be applied. All pinholes shall be marked and repaired using manufacturer's approved Patch Kit, or other approved method.

3.04 ADJUSTMENTS AND CLEANING

- A. At the completion of the Work, APPLICATOR shall remove all materials and debris associated with the Work of this Section.
- B. Clean all surfaces not designated to receive protective coating. Restore all other work in a manner acceptable to ENGINEER.
- C. All finished protective lining Work shall be protected from damage until Final Acceptance of the Work. Protective lining damaged in any manner shall be repaired or replaced at the discretion of ENGINEER at no additional cost to OWNER.
- D. Clean all protective lining as recommended by the manufacturer to provide finished Work acceptable to OWNER, just prior to Final Acceptance

3.05 OMISSIONS

Care has been taken to delineate herein those surfaces to be coated. However, if coating requirements have been inadvertently omitted from this section or any other section of the specifications, it is intended that all metal wetwell and concrete manhole surfaces, unless specifically exempted herein, shall receive a first-class protective coating equal to that given the same type surface pursuant to these specifications.

End of Protective Coatings Requirements

ATTACHMENT A:
LEAD PAINT ANALYSIS REPORT

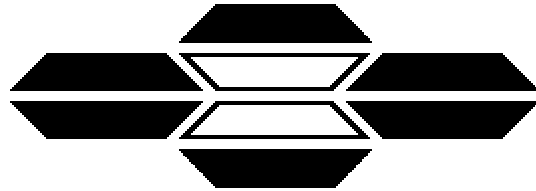

ASBESTOS TEM LABORATORIES, INC.

**ATEM SOP-AA-01
(EPA 3050B/EPA 7420)**

Lead Paint Analysis Report

Laboratory Job # 384988

3431 Ettie St.
Oakland, CA 94608
(510) 704-8930
FAX (510) 704-8429



ASBESTOS TEM LABORATORIES, INC



LAB # 101754
California DPH
ELAP ID #1866

Jun/21/2023

Darel Barlow
Incline Village
1220 Sweetwater Rd
Incline Village, Nevada

RE: LABORATORY JOB # 384988
Atomic Absorption Spectroscopy analytical results for 1 paint sample(s).
Job Site: SPS #5
Job No.:

Enclosed please find results for the atomic absorption spectroscopy (AA) metals analysis of one or more paint samples. Sample preparation and analysis procedures were performed according to ATEM SOP-AA-01 (EPA 3050B / EPA 7420).

Prior to analysis, samples are checked for damage and disruption of the chain-of-custody seal. Samples are then logged-in, each given a unique laboratory number, and a hard copy containing all pertinent information is generated. This, and all other relevant paper work are kept with each sample throughout the analytical procedures to assure proper analysis.

A portion of each sample is weighed out such that an aliquot of ~0.2 grams is obtained. The weighed sample material is then placed into a digestion vessel, transferred to a fume hood, heated at ~95 Deg. C, refluxed with nitric acid to solubilize the contained metals, and treated with hydrogen peroxide to oxidize any organic binder present in the sample material. High purity water is added to make a 50 ml volume for each sample.

AA analysis is performed on a microprocessor controlled Perkin Elmer AAnalyst 300 atomic absorption spectrophotometer, operating in the flame mode. Samples are diluted as needed to allow reading of concentrations in the calibration range. QC analyses are prepared and performed along with each sample batch to ensure accurate analytical determinations. Data is compiled into a standard report format and subjected to a thorough quality assurance check before the information is released to the client.

Sincerely Yours,

Laboratory Manager
ASBESTOS TEM LABORATORIES, INC.

Note: Results for routine quality control samples run in parallel to the samples reported here were within acceptable limits.

Additional Note: Wherever possible, Asbestos TEM Laboratories highly recommends the submission of field blanks with each sample set. It is recommended to analyze field blanks collected in parallel to all samples collected in the field as a check against media contamination from the manufacturer or in the field. Sample results are not corrected for contamination based on the field blank(s) or other analytical blank(s).

Disclaimer - These results relate only to the samples tested as received and must not be reproduced, except in full, with the approval of the laboratory. Incorrect or illegible information supplied by the customer may adversely affect the validity of test results. This report must not be used to claim product endorsement by AIHA or any other agency of the U.S. Government.

**ATOMIC ABSORPTION SPECTROSCOPY
LEAD PAINT ANALYSIS REPORT
ATEM SOP-AA-01 (EPA 3050B / EPA 7000B)**

Contact: Darel Barlow	Samples Submitted: 1	Report No.: 384988
Address: Incline Village	Samples Analyzed: 1	Date Submitted: Jun-21-23
1220 Sweetwater Rd	Job Site / No.	Date Reported: Jun-21-23
Incline Village, Nevada	SPS #5	

SAMPLE ID	METAL	SAMPLE RESULT	REPORTING LIMIT	LOCATION / DESCRIPTION		
SPS-5WW	Pb	210 mg/kg	46 mg/kg			
Lab ID # 96-07772-001		0.021 %	0.005 %	<u>Sampling Date</u>	<u>Analysis Date</u> Jun-21-23	<u>Analyzed Weight (g)</u> 0.2155
Lab ID #				<u>Sampling Date</u>	<u>Analysis Date</u>	<u>Analyzed Weight (g)</u>
Lab ID #				<u>Sampling Date</u>	<u>Analysis Date</u>	<u>Analyzed Weight (g)</u>
Lab ID #				<u>Sampling Date</u>	<u>Analysis Date</u>	<u>Analyzed Weight (g)</u>
Lab ID #				<u>Sampling Date</u>	<u>Analysis Date</u>	<u>Analyzed Weight (g)</u>
Lab ID #				<u>Sampling Date</u>	<u>Analysis Date</u>	<u>Analyzed Weight (g)</u>
Lab ID #				<u>Sampling Date</u>	<u>Analysis Date</u>	<u>Analyzed Weight (g)</u>
Lab ID #				<u>Sampling Date</u>	<u>Analysis Date</u>	<u>Analyzed Weight (g)</u>
Lab ID #				<u>Sampling Date</u>	<u>Analysis Date</u>	<u>Analyzed Weight (g)</u>
Lab ID #				<u>Sampling Date</u>	<u>Analysis Date</u>	<u>Analyzed Weight (g)</u>
Lab ID #				<u>Sampling Date</u>	<u>Analysis Date</u>	<u>Analyzed Weight (g)</u>

Analytical results posted above relate only to the material(s) tested.
The sample has not been blank corrected.

µg - micrograms 1% = 10,000 ppm 1ppm = 1 mg/Kg

Lab QC Reviewer Jo Ann Huerto
Jo Ann Huerto

Analyst Jie Zhang
Jie Zhang



ATEM LABORATORIES CHAIN OF CUSTODY

384988

CALIFORNIA: 3431 Ettie Street Oakland, CA 94608

Phone (510) 704-8930 Fax (510) 704-8429

NEVADA: 1350 Freeport Blvd. #104, Sparks, NV 89431

Phone (775) 359-3377 Fax (775) 359-2798

You may also email this chain of custody to asbestastemlabs.ca@gmail.com

* denotes required field

Company: <u>Incline Village</u>		Contact: * <u>Darel Barlow</u>		Phone: * <u>775-832-1399</u>		Email: * <u>dcb@ivgid.org</u>								
Address: * <u>1720 Sweetwater Rd.</u>		City: * <u>Incline Village</u>		State: * <u>NV</u> Zip: <u>89451</u>		Email:								
Job Site: * <u>SPS # 5</u>		Job #:		PO #:		Email:								
Reporting *	<input checked="" type="checkbox"/> Email	<input type="checkbox"/> Phone	<input type="checkbox"/> Fax	<input type="checkbox"/> Mail	<input type="checkbox"/> Pickup	Billing	<input checked="" type="checkbox"/> Email	<input type="checkbox"/> Fax	<input type="checkbox"/> Mail	<input type="checkbox"/> Pre-Paid	Billing Email:			
Results Due:*	<input type="checkbox"/> 2 HR <input type="checkbox"/> 4 HR <input type="checkbox"/> 6 HR <input checked="" type="checkbox"/> 8 HR <input type="checkbox"/> 24 HR <input type="checkbox"/> 48 HR <input type="checkbox"/> 3 DAY <input type="checkbox"/> 5 DAY <input type="checkbox"/> 10 DAY <input type="checkbox"/> Hold Samples (Until _____) <input type="checkbox"/> After Hours: **													
Asbestos Air	<input type="checkbox"/> PCM NIOSH 7400 <input type="checkbox"/> A <input type="checkbox"/> B		<input type="checkbox"/> TEM AHERA		<input type="checkbox"/> TEM CARB Mod. AHERA		<input type="checkbox"/> TEM EPA Yamate Level II		<input type="checkbox"/> TEM NIOSH 7402		<input type="checkbox"/> ISO 10312 <input type="checkbox"/> ISO 13794	<input type="checkbox"/> Sensitivity _____		
Asbestos Bulk	<input type="checkbox"/> PLM Standard (EPA 600/R-93-1)		<input type="checkbox"/> PLM 400 Point Count		<input type="checkbox"/> PLM 1000 PC		<input type="checkbox"/> PLM 400 PC Gravimetric Reduction		<input type="checkbox"/> PLM 1000 PC Grav. Red.		<input type="checkbox"/> TEM EPA Qualitative <input type="checkbox"/> TEM EPA Quantitative			
Asbestos Soils	<input type="checkbox"/> CARB 435 Prep Only		<input type="checkbox"/> CARB 435 PLM		<input type="checkbox"/> 400 PC <input type="checkbox"/> 800 PC <input type="checkbox"/> 1000 PC <input type="checkbox"/> 1200 PC		<input type="checkbox"/> EPA Soil Screening Qualitative		<input type="checkbox"/> TEM-NOA EPA/CARB Quantitative		<input type="checkbox"/> Erionite			
Asbestos Dust	<input type="checkbox"/> ASTM D-5755 Fiber Count		<input type="checkbox"/> ASTM D-5756 Wt. %		<input type="checkbox"/> ASTM D-5756 Mass		<input type="checkbox"/> ASTM D-6480 Dust Wipe		<input type="checkbox"/> Total Particulates (Gravimetric)					
Asbestos Water	<input type="checkbox"/> 100.2 Potable Drinking Water		<input type="checkbox"/> 100.1 Non Potable Water		<i>note that 100.2 will be used for all water samples unless otherwise requested</i>									
Lead/Silica	<input checked="" type="checkbox"/> Lead Paint Chips EPA-SW-846 7000B		<input type="checkbox"/> Lead Dust Wipe EPA-SW-846 7000B		<input type="checkbox"/> Lead Air NIOSH 7082		<input type="checkbox"/> Lead Soil EPA-SW-846 7000B		<input type="checkbox"/> Crystalline Silica Air (NIOSH 7500) <input type="checkbox"/> Single Species <input type="checkbox"/> All Species		<input type="checkbox"/> Crystalline Silica in Bulk (NIOSH 7500) <input type="checkbox"/> Single Species <input type="checkbox"/> All Species		<input type="checkbox"/> Respirable Crystalline Silica in Bulk (NIOSH 7500) <input type="checkbox"/> Single Species <input type="checkbox"/> All Species	
Custom/Other	<input type="checkbox"/> Custom Analysis **				<input type="checkbox"/> TEM Chatfield (Semi-Quant)		<input type="checkbox"/> NIOSH 0500		<input type="checkbox"/> NIOSH 0600		<input type="checkbox"/> TTLC <input type="checkbox"/> STLC <input type="checkbox"/> TCLP			
Special Instruct.	<input type="checkbox"/> Composite		<input type="checkbox"/> Prep Only		<input type="checkbox"/> 8 Hour TWA		Other **							
Sample # *	Sample Type	Date Collected	Time On	Time Off	Total Time (min)	Flow Rate (lpm)			Volume or Area Sampled	Hold Sample	Description *			
						On	Off	Average						
<u>SPS-5ww</u>										<input type="checkbox"/>				
										<input type="checkbox"/>				
										<input type="checkbox"/>				
										<input type="checkbox"/>				
										<input type="checkbox"/>				
										<input type="checkbox"/>				
										<input type="checkbox"/>				
										<input type="checkbox"/>				
										<input type="checkbox"/>				
										<input type="checkbox"/>				
										<input type="checkbox"/>				
										<input type="checkbox"/>				
										<input type="checkbox"/>				
										<input type="checkbox"/>				
										<input type="checkbox"/>				
										<input type="checkbox"/>				
Submitted By * <u>Darel Barlow</u>	Received By <u>JoAnn Hudo</u>					JUN20 '23 4:49PM								
Date/Time Submitted * <u>6-15-23 15:30PM</u>	Date/Time Received													
Submitted By	Received By													
Date/Time Submitted	Date/Time Received													

MTZ

JUN21 '23 10:01AM

JUN20 '23 4:49PM

** For any special instructions, RUSH results or Custom Analysis, you must clarify these specifications AND, of more importance, contact us here at ATEM ahead of time to manage scheduling to meet your requests. This includes dropping off samples for rush, same day analysis. Drop off and processing of samples after hours cannot be accommodated without proper notification from you, and confirmation by ATEM staff. All samples will be held for 3 months from the date of receipt at ATEM. Additional sample storage time may be obtained through ATEM Customer Service.

INCLINE VILLAGE GENERAL IMPROVEMENT DISTRICT

SPS-5 WETWELL AND MANHOLE REHABILITATION

PWP# WA-2024-055



1220 SWEETWATER RD.
INCLINE VILLAGE,
NV 89451
P: 775.832.1203

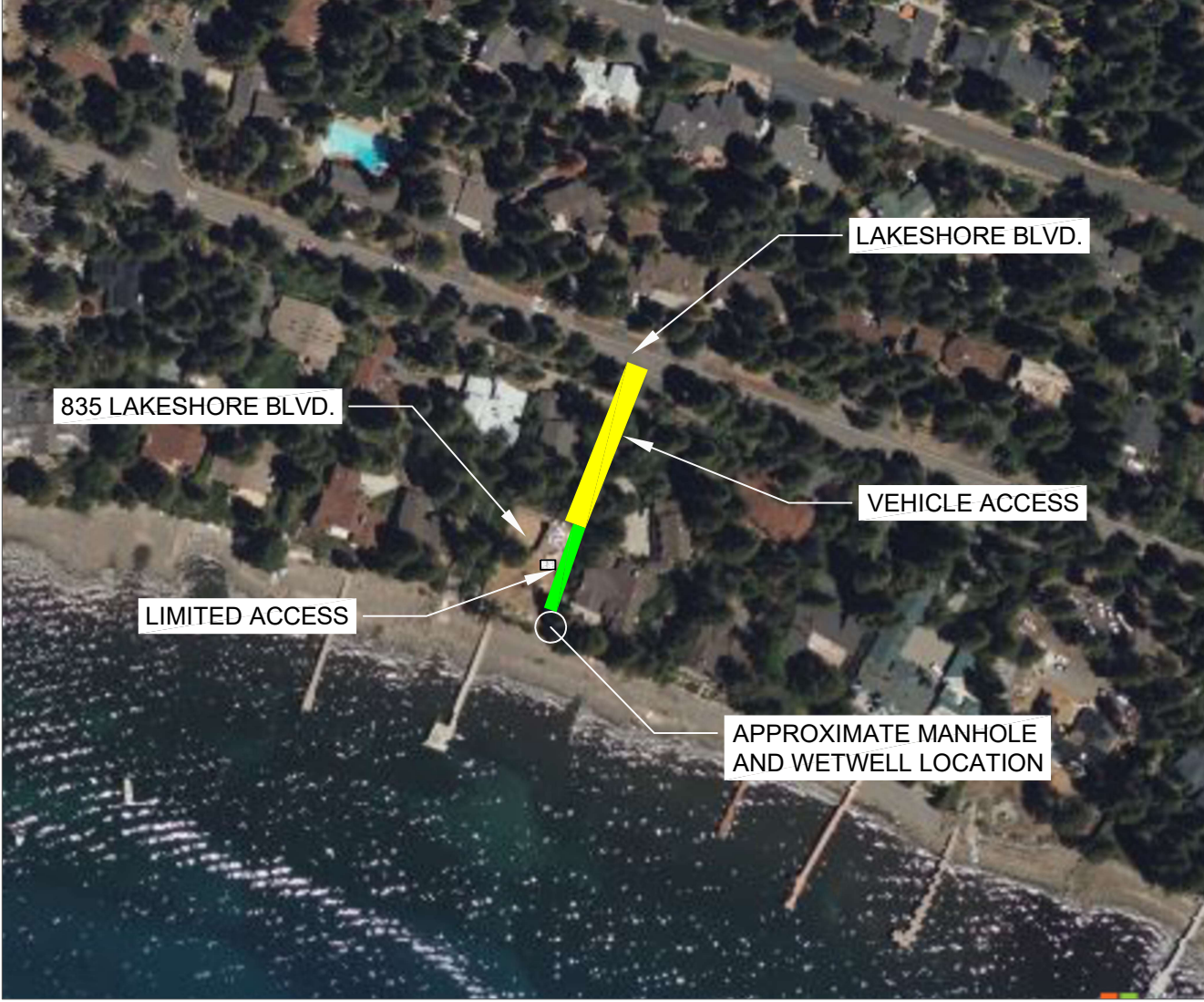
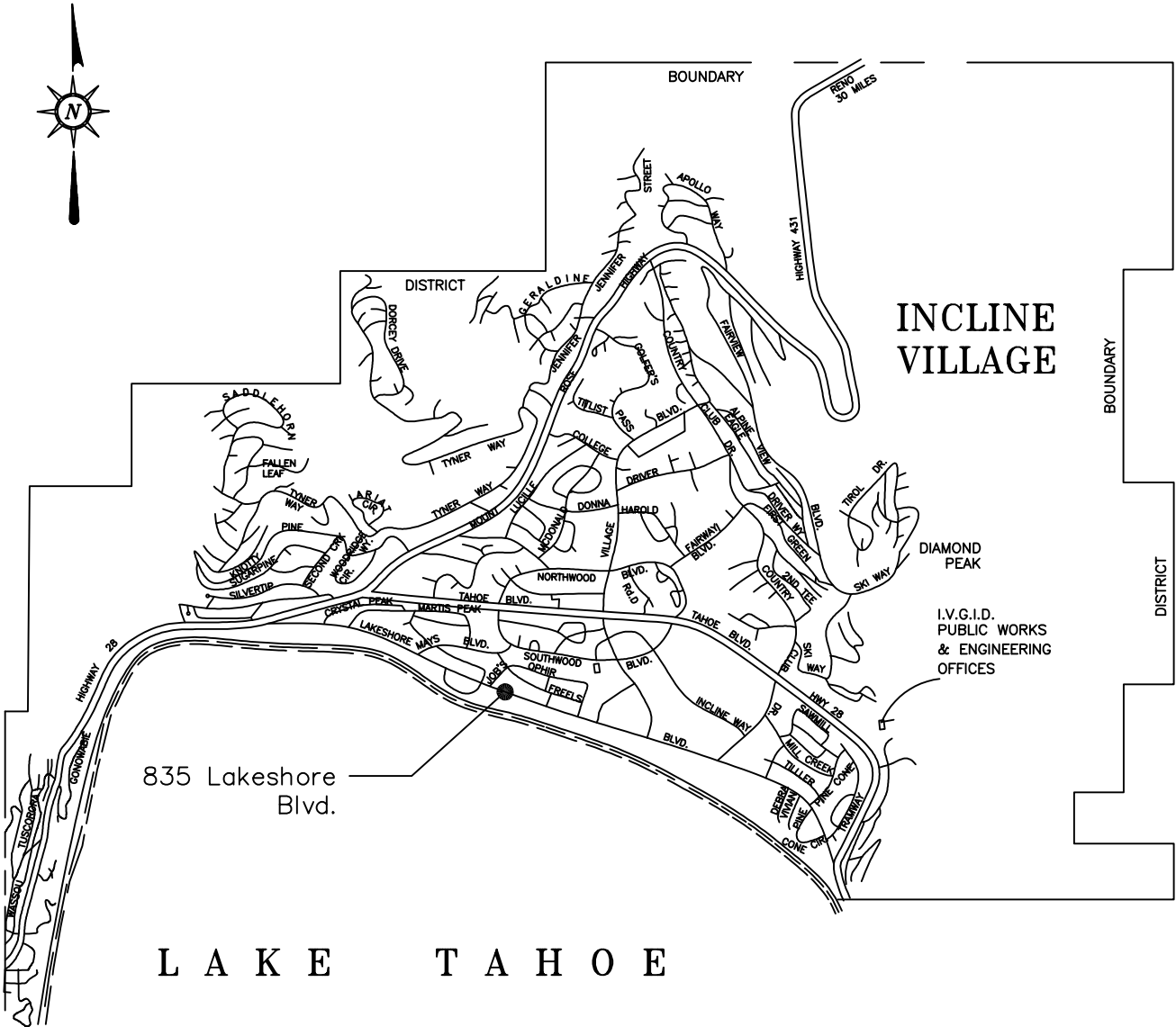

PROJECT SITE

SHEET LIST	
SHEET #	DESCRIPTION
G1	COVER SHEET
C1	SITE PLAN
C2	DETAILS

SPS-5 WETWELL AND MANHOLE REHABILITATION

REVISION #	DATE	DESCRIPTION

PROJECT #:	NA
DATE:	4/24/2024
SHEET SCALE:	N.T.S
SHEET DESCRIPTION:	COVER PAGE
SHEET #:	G1

U:\Engineering\Projects\Current & Ongoing Projects\2024 SPS-5 Wetwell and Manhole Rehabilitation\1 - Design\Designs\SPS 5 Plan Set.dwg

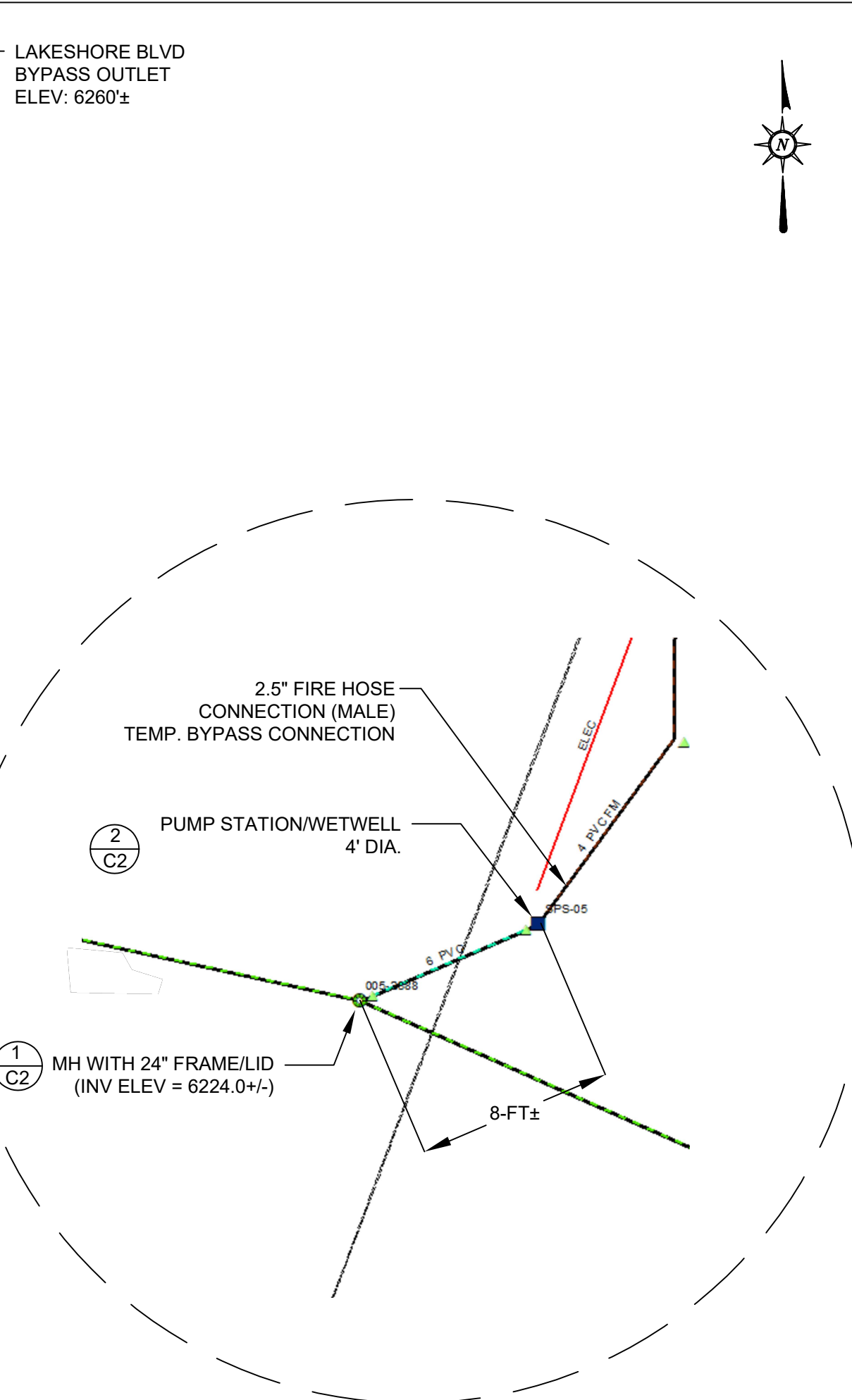
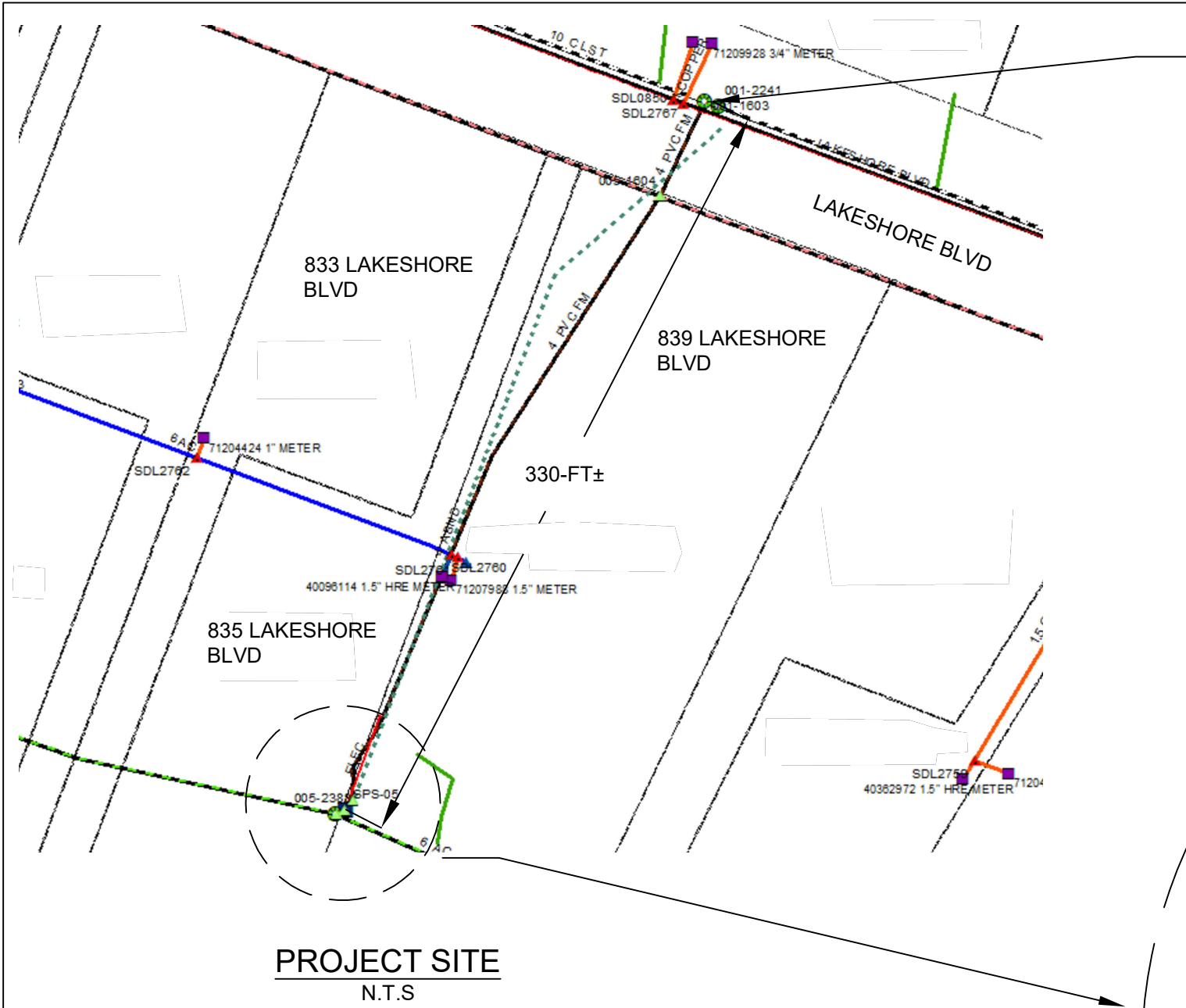

- NOTES:**
1. ACCESS TO SPS-5 RESTRICTED TO EAST SIDE OF RESIDENCE AT 835 LAKESHORE BLVD.
 2. PRIVATE RESIDENTIAL CONSTRUCTION WILL BE ACTIVE ON SITE THROUGHOUT DURATION OF IVGID PROJECT. IVGID CONTRACTOR TO COORDINATE WITH RESIDENTIAL CONTRACTOR, AS NECESSARY.
 3. ACCESS TO BE COORDINATED WITH IVGID AND PRIVATE RESIDENTIAL CONTRACTOR.
 4. VEHICLE ACCESS IS LIMITED TO PAVED DRIVEWAY AT 835 LAKESHORE. THERE IS LIMITED EQUIPMENT ACCESS FROM THE DRIVEWAY TO THE WETWELL.

SPS-5 WETWELL AND MANHOLE REHABILITATION

REVISION #	DATE	DESCRIPTION

PROJECT #:	NA
DATE:	4/24/2024
SHEET SCALE:	N.T.S.
SHEET DESCRIPTION:	SITE PLAN
SHEET #:	C1

u:\Engineering\Projects\Current & Ongoing Projects\2024 SPS-5 Wetwell and Manhole Rehabilitation\1 - Design\Designs\SPS 5 Plan Set.dwg

MANHOLE NOTES:

1. 3 EA 6" PIPE OPENINGS.
2. 4 EA ELECTRICAL PENETRATIONS <2" DIA.
3. CONTRACTOR TO INSTALL NEW BENCHING IN MANHOLE

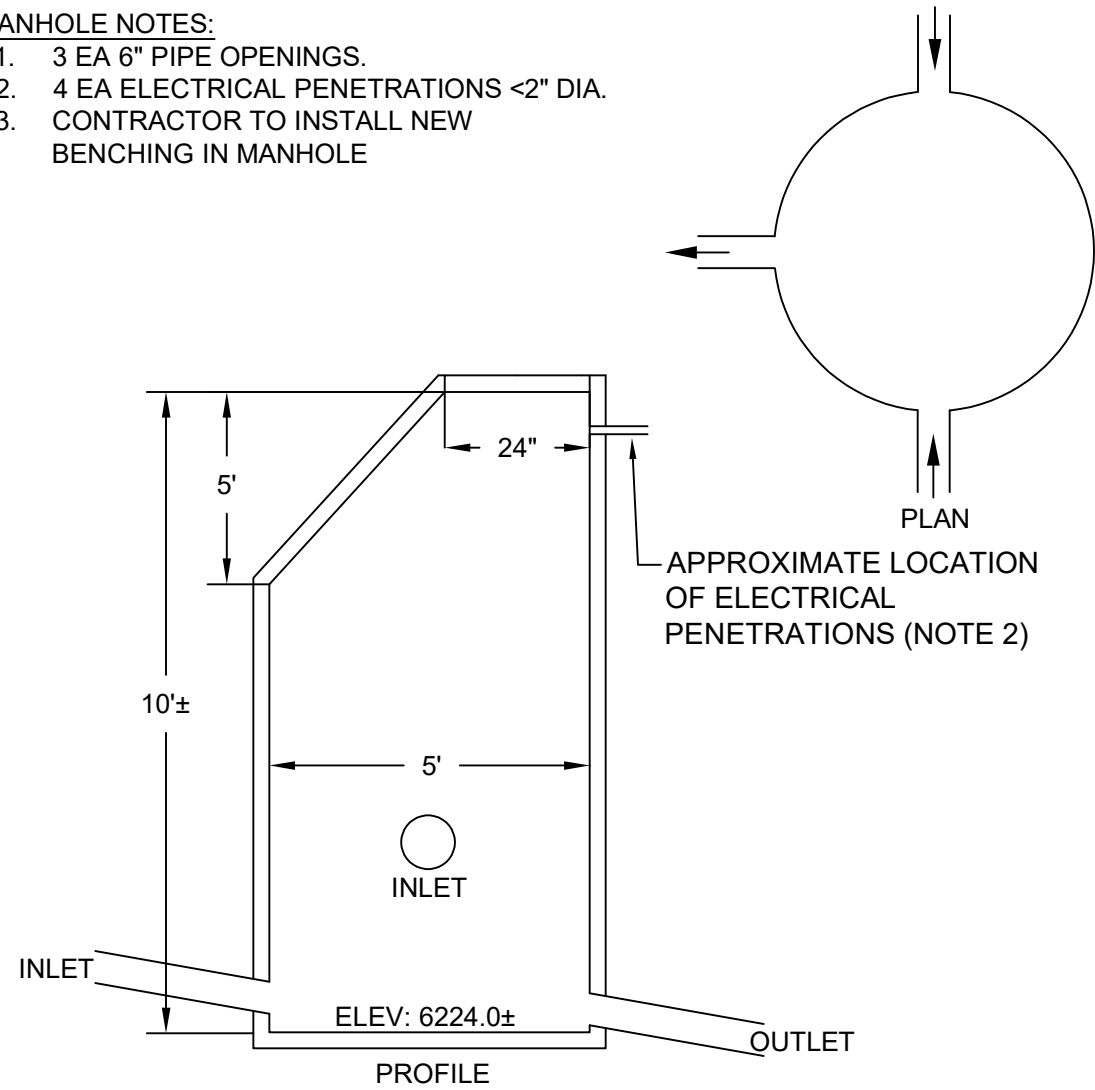

DETAIL 1: MANHOLE DIMENSIONS

N.T.S.

WETWELLS NOTES:

1. LEAD IS PRESENT IN THE EXISTING WETWELL COATING. SEE SPECIFICATION FOR LAB ANALYSIS AND ABATEMENT REQUIREMENTS.
2. REMOVE AND DISPOSE OF EXISTING LADDER INSIDE OF WETWELL.
3. CONTRACTOR TO PROVIDE METHODOLOGY FOR WETWELL ACCESS PROCEDURES. ACCESS PROCEDURES MUST ADHERE TO ALL PERTINENT OSHA REGULATIONS, INCLUDING BUT NOT LIMITED TO CONFINED SPACE.
4. PREPARE AND COAT 6" STEEL INLET PIPE APPROX: 30" LENGTH
5. CONTRACTOR TO PROVIDE METHODOLOGY FOR TEMPORARY REMOVAL AND REINSTATEMENT OF PUMP STATION HARDWARE AS REQUIRED TO FACILITATE ACCESS, PREPARATION, AND FINAL COATING OF WETWELL INTERIOR SURFACE.

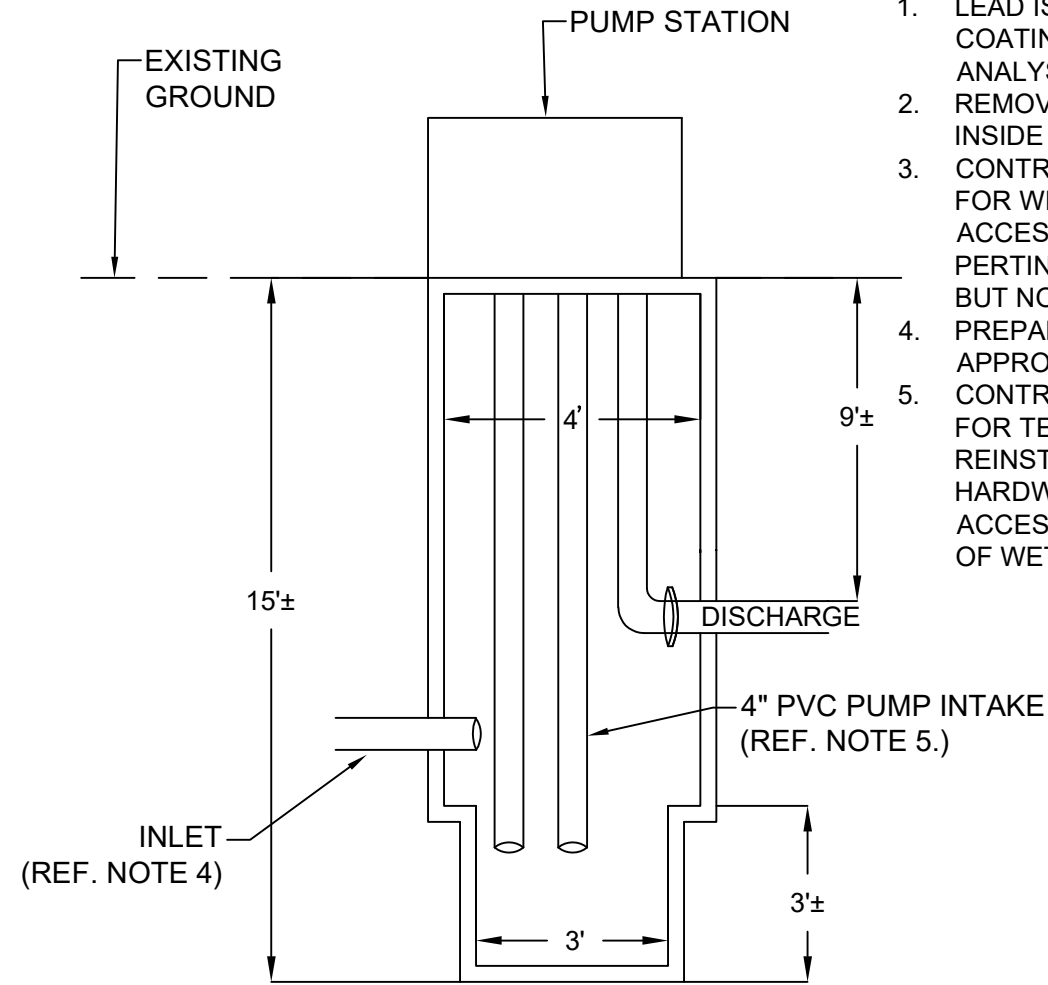

DETAIL 2: WETWELL DIMENSIONS

N.T.S.

GENERAL NOTES:

1. CONTRACTOR RESPONSIBLE FOR TEMPORARY BYPASS OF MANHOLE AND WETWELL, AS REQUIRED. EXISTING IVGID ALARM CONTROLS AVAILABLE DURING BYPASS.
2. IVGID PERSONNEL WILL BE USED AS IMMEDIATE RESPONDERS IN THE EVENT OF ALARM, CONTRACTOR TO PROVIDE SECONDARY SUPPORT.
3. CONTRACTOR TO PREPARE WETWELL AND MANHOLE SURFACES PER MANUFACTURER SPECIFICATIONS.
4. CONTRACTOR IS RESPONSIBLE TO PERFORM APPROPRIATE CONTAINMENT AND SITE PROTECTION PER SPECIFICATIONS.
5. CONTRACTOR TO COAT BOTH MANHOLE AND WETWELL PER MANUFACTURER SPECIFICATIONS.
6. AT ALL TIMES DURING CONSTRUCTION, TEMPORARY EROSION CONTROLS SHALL BE IN PLACE. EROSION CONTROL SHALL BE IN ACCORDANCE WITH THE TRPA "HANDBOOK OF BEST MANAGEMENT PRACTICES." THE SITE SHALL BE WINTERIZED IN ACCORDANCE WITH THE SPECIFICATIONS AND STANDARD TRPA REQUIREMENTS FROM OCTOBER 15TH TO MAY 1ST.



1220 SWEETWATER RD.
INCLINE VILLAGE,
NV 89451
P: 775.832.1203

**SPS-5 WETWELL AND MANHOLE
REHABILITATION**

REVISION # DATE DESCRIPTION

PROJECT #:

NA

DATE:

4/24/2024

SHEET SCALE:

N.T.S

SHEET DESCRIPTION:

DETAILS

SHEET #:

C2