

MEMORANDUM

TO: Board of Trustees

THROUGH: Indra Winquest
District General Manager

Paul Navazio
Director of Finance

FROM: Mike Bandelin
Diamond Peak General Manager

SUBJECT: Review, discuss and possibly approve a Procurement Contract for the Manufacturing and Delivery of a replacement Surface Lift; 2021/2022 Capital Improvement Project; Fund: Community Services; Program: Ski; Project #3467LE1703; Vendor: Star Lifts, USA, in the amount of \$55,565.00

DATE: August 10, 2021

I. RECOMMENDATION

That the Board of Trustees makes a motion to:

1. Award a procurement contract to Vendor - Star Lifts USA totaling \$55,565.00 for the manufacturing and delivery of a replacement Surface lift to Diamond Peak Ski Resort.
2. Authorize Staff to execute all purchase documents based on a review by General Counsel and Staff.

II. BACKGROUND

The general purpose of this project is to maintain District operations through the necessary maintenance and replacement cycles. The contract proposed for award addresses the end of life cycle replacement of the Child Ski Center Surface lift. The existing surface lift was purchased in 1997, manufactured by Sunkid North America and has provided service to our customers for 25 operating seasons. The lift is used exclusively by children ages 3-6 participating in a lesson within ski areas Child Ski Center. On an annual basis, the Child Ski Center will provide lessons to an average of 5,976 children, or 4% of total skier visit count. The 2021/2022 Child Ski Center operating budget references a budgeted amount of \$926,258.00 in

Review, discuss and possibly approve a -2-
Procurement Contract for the manufacturing
and delivery of a replacement surface
lift - 2021/2022 CIP Project: Fund: Community Services; Program: Ski;
Project # 3467LE1703; Vendor: Star Lifts, USA, in the
amount of \$55,565.00

August 10, 2021

sales and fees revenue and includes \$446,895.29 in total operating expenses. The surface lift proposed for purchase is nearly identical in length as the existing lift at 50 feet in length. The existing lift is equipped with a high density plastic chain-style conveyor, and the proposed lift will be equipped with a rubber belt conveyor and the width of the side platform walkway is increased from 12 inches to 18 inches. Additionally, the motor drive, tension system and safety controls are upgraded and the entire proposed piece of equipment per the bid specifications will be constructed to meet ANSI B77.1 – 2017.

In accordance with Board Policy 3.1.0., 0.15 Consent Calendar, this item is included on the Consent Calendar as it is routine business of the District and within the currently approved District Budget.

III. **BID RESULTS**

The District publicly advertised this project for bidding, and Requests for Proposals, including specifications, were sent out to three potential bidders. Two bids were received and opened on July 22, 2021; the third potential bidder declined to submit a bid due to the requested delivery date of the lift. The bid results are as follows:

Vendor	Total Bid Amount
Star Lifts USA (Sunkid)	\$55,565.00
Sun Valley Ski Tools (Team Service)	\$57,720.00
Magic Carpet	Declined

The low responsive bidder is Star Lifts, USA. District Staff reviewed the bid documents and checked references for the vendor and has recommended award of this procurement to Star Lifts USA.

IV. **FINANCIAL IMPACT AND BUDGET**

A total of \$75,000 is included in the 2021/2022 Capital Improvement Program Budget for the procurement of a surface conveyor lift to replace the existing asset (see attached data sheet). The purchase price proposed for award totals \$55,565.00 which is \$19,435.00 below the budgeted amount.

Review, discuss and possibly approve a Procurement Contract for the manufacturing and delivery of a replacement surface lift - 2021/2022 CIP Project: Fund: Community Services; Program: Ski; Project # 3467LE1703; Vendor: Star Lifts, USA, in the amount of \$55,565.00

-3-

August 10, 2021

V. ALTERNATIVES

The Board of Trustees could defer or eliminate the replacement project. Doing so will result in an impact to the customer experience as well as puts the District at risk of increased maintenance expenses or potential increased lift down time.

VI. BUSINESS IMPACT

This item is not a "rule" within the meaning of Nevada Revised Statutes, Chapter 237, and does not require a Business Impact Statement.

VII. ATTACHMENTS

- A. Procurement agreement documents; IVGID – Star Lifts USA
- B. Proposal documents Star Lifts USA
- C. IVGID project summary #3467LE1703 data sheet
- D. District Purchase Order

INCLINE VILLAGE GENERAL IMPROVEMENT DISTRICT PURCHASE AGREEMENT

This Equipment Purchase Agreement (“Agreement”) is entered into on Date by and between the Incline Village General Improvement District, a Nevada general improvement district (“District”), and **Star Lifts USA, Inc.**, a Domestic Profit Corporation, with its principal place of business at 54 Depot Road, Sunapee, New Hampshire (“Contractor”). District and Contractor are sometimes individually referred to as “Party” and collectively as “Parties” in this Agreement.

Section 1 - Definitions.

- A. “Equipment” means all machinery, equipment, items, parts, materials, labor or other services, including design, engineering and installation services, provided by Contractor as specified in Exhibit A, original Request for Proposals for the **Diamond Peak Ski Resort Conveyor Surface Lift Procurement**, and Contractor’s Proposal dated July 20, 2021 provided by Contractor, attached hereto and incorporated herein by reference.
- B. “Delivery Date(s)” means that date or dates upon which the Equipment is to be delivered to District, ready for approval, testing and/or use as specified in Exhibit A.

Section 2 - Materials and Workmanship.

When Exhibit A specifies machinery, equipment or material by manufacturer, model or trade name, no substitution will be made without District’s written approval. Machinery, equipment or material installed in the Equipment without the approval required by this Section 2 - will be deemed to be defective material for purposes of Section 4 - . Where machinery, equipment or materials are referred to in Exhibit A as equal to any particular standard, District will decide the question of equality. When requested by District, Contractor will furnish District with the name of the manufacturer, the performance capabilities and other pertinent information necessary to properly determine the quality and suitability of any machines, equipment and material to be incorporated in the Equipment. Material samples will be submitted at District’s request.

Section 3 - Inspections and Tests.

District shall have the right to inspect and/or test the Equipment prior to acceptance. If upon inspection or testing the Equipment or any portion thereof are found to be nonconforming, unsatisfactory, defective, of inferior quality or workmanship, or fail to meet any requirements or specifications contained in Exhibit A, then without prejudice to any other rights or remedies, District may reject the Equipment or exercise any of its rights under Section 4 - C. The inspection, failure to make inspection, acceptance of goods, or payment for goods shall not impair District’s right to reject nonconforming goods, irrespective of District’s failure to notify Contractor of a rejection of nonconforming goods

or revocation of acceptance thereof or to specify with particularity any defect in nonconforming goods after rejection or acceptance thereof.

Section 4 - Warranty.

- A. Contractor warrants that the Equipment will be of merchantable quality and free from defects in design, engineering, material and workmanship for a period of one year, or such longer period as provided by a manufacturer's warranty or set forth in Exhibit A, from the date of final written acceptance of the Equipment by District as required for final payment under Section 7 - . Contractor further warrants that any services provided in connection with the Equipment will be performed in a professional and workmanlike manner and in accordance with the highest industry standards.
- B. Contractor further warrants that all machinery, equipment or process included in the Equipment will meet the performance requirements and specifications specified in Exhibit A and shall be fit for the purpose intended. District's inspection, testing, approval or acceptance of any such machinery, equipment or process will not relieve Contractor of its obligations under this Section 4 - B.
- C. For any breach of the warranties contained in Section 4 - A and Section 4 - B, Contractor will, immediately after receiving notice from District, at the option of District, and at Contractor's own expense and without cost to District:
 - 1. Repair the defective Equipment;
 - 2. Replace the defective Equipment with conforming Equipment, F.O.B. District's plant, office or other location of District where the Equipment was originally performed or delivered; or
- D. Repay to District the purchase price of the defective Equipment.
- E. If District selects repair or replacement, any defects will be remedied without cost to District, including but not limited to, the costs of removal, repair and replacement of the defective Equipment, and reinstallation of new Equipment. All such defective Equipment that is so remedied will be similarly warranted as stated above. In addition, Contractor will repair or replace other items of the Equipment which may have been damaged by such defects or the repairing of the same, all at its own expense and without cost to District.
- F. Contractor also warrants that the Equipment is free and clear of all liens and encumbrances whatsoever, that Contractor has a good and marketable title to same, and that Contractor owns or has a valid license for all of the proprietary technology and intellectual property incorporated within the Equipment. Contractor agrees to indemnify, defend and hold District harmless against any and all third party claims resulting from the breach or inaccuracy of any of the foregoing warranties.

- G. In the event of a breach by Contractor of its obligations under this Section 4 - , District will not be limited to the remedies set forth in this Section 4 - , but will have all the rights and remedies permitted by applicable law.

Section 5 - Prices.

Unless expressly provided otherwise, all prices and fees specified in Exhibit A, attached hereto and incorporated herein by reference, are firm and shall not be subject to change without the written approval of District. No extra charges of any kind will be allowed unless specifically agreed to in writing by District's authorized representative. Compensation shall be as indicated in Exhibit A, with a total amount of **Fifty-Five Thousand Five Hundred Sixty-Five Dollars (\$55,565.00)** to be billed as a fixed fee, based on percentage complete measured against the estimated time schedule set forth in Exhibit A. In no event shall compensation for any Activity identified in Exhibit A exceed the amount set forth in the attachment. The fixed fee shall include Reimbursable Expenses and all charges for packing, freight and transportation to destination, and Contractor shall not request or receive any additional payments for such expenses.

Section 6 - Changes.

District, at any time, by a written order, and without notice to any surety, may make changes in the Equipment, including but not limited to, District's requirements and specifications. If such changes affect the cost of the Equipment or time required for its performance, an equitable adjustment will be made in the price or time for performance or both. Any change in the price necessitated by such change will be agreed upon between District and Contractor and such change will be authorized by a change order document signed by District and accepted by Contractor.

Section 7 - Payments.

- A. Terms of payment, are net thirty (30) days, less any applicable retention, after receipt of invoice, or completion of applicable Progress Milestones. Final payment shall be made by District after Contractor has satisfied all contractual requirements. Payment of invoices shall not constitute acceptance of Equipment. All invoices shall be sent to AP@IVGID.ORG, with a copy to JAY@IVGID.ORG.
- B. If progress milestones have been specified within Exhibit A, then payments for the Equipment will be made as the requirements of such progress milestones are met. Progress payments for the Equipment will be made by District upon proper application by Contractor during the progress of the Equipment and according to the terms of payment as specified in Exhibit A. Contractor's progress billing invoice will include progress payments due for the original scope of work and changes. Each "Item for Payment" shown in Exhibit A and each change order will be itemized on the invoice. Invoices for cost plus work, whether part of Exhibit A or a change order, must have subcontractor and/or supplier invoices attached to Contractor's invoice. Other format and support documents for invoices will be determined by District in advance of the first invoice cycle.

- C. Payments otherwise due may be withheld by District on account of defective Equipment not remedied, liens or other claims filed, reasonable evidence indicating probable filing of liens or other claims, failure of Contractor to make payments properly to its subcontractors or for material or labor, the failure of Contractor to perform any of its other obligations under the Agreement, or to protect District against any liability arising out of Contractor's failure to pay or discharge taxes or other obligations. If the causes for which payment is withheld are removed, the withheld payments will be made promptly. If the said causes are not removed within a reasonable period after written notice, District may remove them at Contractor's expense.
- D. Payment of the final progress milestone or any retention will be made by District upon:
 - 1. Submission of an invoice for satisfactory completion of the requirements of a progress milestone as defined in Exhibit A and in the amount associated with the progress milestone;
 - 2. Written acceptance of the Equipment by District;
 - 3. Delivery of all drawings and specifications, if required by District;
 - 4. Delivery of executed full releases of any and all liens arising out of this Agreement; and
 - 5. Delivery of an affidavit listing all persons who might otherwise be entitled to file, claim or maintain a lien of any kind or character, and containing an averment that all of the said persons have been paid in full.
 - 6. If any person refuses to furnish an actual release or receipt in full, Contractor may furnish a bond satisfactory to District to indemnify District against any claim or lien at no cost to District.
- E. Acceptance by Contractor of payment of the final progress milestone pursuant to Section 7 - D will constitute a waiver, release and discharge of any and all claims and demands of any kind or character which Contractor then has, or can subsequently acquire against District, its successors and assigns, for or on account of any matter or thing arising out of, or in any manner connected with, the performance of this Agreement. However, payment for the final progress milestone by District will not constitute a waiver, release or discharge of any claims or demands which District then has, or can subsequently acquire, against Contractor, its successors and assigns, for or on account of any matter or thing arising out of, or in any manner connected with, the performance of this Agreement.

Section 8 - Schedule for Delivery.

- A. The time of Contractor's performance is of the essence for this Agreement. The Equipment will be delivered in accordance with the schedule set forth in Exhibit A. Contractor must immediately notify District in writing any time delivery is behind

schedule or may not be completed on schedule. In addition to any other rights District may have under this Agreement or at law, Contractor shall pay District the sum of \$100.00 for each calendar day for which the Equipment is unavailable beyond the scheduled delivery date(s) specified in Exhibit A.

- B. In the event that the Equipment is part of a larger project or projects that require the coordination of multiple contractors or suppliers, then Contractor will fully cooperate in scheduling the delivery so that District can maximize the efficient completion of such project(s).

Section 9 - Taxes.

- A. Per Section 2.B.9, prices quoted for the Equipment must be exclusive of Federal and State taxes, as the District is exempt from such taxes.
- B. Contractor will withhold, and require its subcontractors, where applicable, to withhold all required taxes and contributions of any federal, state or local taxing authority which is measured by wages, salaries or other remuneration of its employees or the employees of its subcontractors. Contractor will deposit, or cause to be deposited, in a timely manner with the appropriate taxing authorities all amounts required to be withheld.
- C. All other taxes, however denominated or measured, imposed upon the price of the Equipment provided hereunder, will be the responsibility of Contractor. In addition, all taxes assessed by any taxing jurisdiction based on Contractor property used or consumed in the provision of the Equipment such as and including ad valorem, use, personal property and inventory taxes will be the responsibility of Contractor.
- D. Contractor will, upon written request, submit to District written evidence of any filings or payments of all taxes required to be paid by Contractor hereunder.

Section 10 - Independent Contractor.

Contractor enters into this Agreement as an independent contractor and not as an employee of District. Contractor shall have no power or authority by this Agreement to bind District in any respect. Nothing in this Agreement shall be construed to be inconsistent with this relationship or status. All employees, agents, contractors or subcontractors hired or retained by the Contractor are employees, agents, contractors or subcontractors of the Contractor and not of District. District shall not be obligated in any way to pay any wage claims or other claims made against Contractor by any such employees, agents, contractors or subcontractors or any other person resulting from performance of this Agreement.

Section 11 - Subcontracts.

Unless otherwise specified, Contractor must obtain District's written permission before subcontracting any portion of the Equipment. Except for the insurance requirements in Section 13 - A, all subcontracts and orders for the purchase or rental of supplies, materials or equipment, or any other part of the Equipment, will require that the subcontractor be

bound by and subject to all of the terms and conditions of the Agreement. No subcontract or order will relieve Contractor from its obligations to District, including, but not limited to Contractor's insurance and indemnification obligations. No subcontract or order will bind District.

Section 12 - Title and Risk of Loss.

Unless otherwise agreed, District will have title to, and risk of loss of, all completed and partially completed portions of the Equipment upon delivery, as well as materials delivered to and stored on District property which are intended to become a part of the Equipment. However, Contractor will be liable for any loss or damage to the Equipment and/or the materials caused by Contractor or its subcontractors, their agents or employees, and Contractor will replace or repair said Equipment or materials at its own cost to the complete satisfaction of District. Notwithstanding the foregoing, in the event that the District has paid Contractor for all or a portion of the Equipment which remains in the possession of Contractor, then District shall have title to, and the right to take possession of, such Equipment at any time following payment therefor. Risk of loss for any Equipment which remains in the possession of Contractor shall remain with Contractor until such Equipment has been delivered or District has taken possession thereof. Contractor will have risk of loss or damage to Contractor's property used in the construction of the Equipment but which does not become a part of the Equipment.

Section 13 - Indemnification.

- A. To the fullest extent permitted by law, Contractor shall defend, indemnify and hold the District, its officials, officers, employees, volunteers and agents free and harmless from any and all claims, demands, causes of action, costs, expenses, liability, loss, damage or injury, in law or equity, to property or persons, including wrongful death, in any manner arising out of or incident to any alleged acts, omissions, negligence or willful misconduct of Contractor, its officials, officers, employees, agents, subcontractors and subconsultants arising out of or in connection with the Equipment or the performance of this Agreement, including without limitation the payment of all consequential damages and attorneys' fees and other related costs and expenses except such loss or damage which was caused by the sole negligence or willful misconduct of the District.
- B. Contractor's defense obligation for any and all such aforesaid suits, actions or other legal proceedings of every kind that may be brought or instituted against the District, its officials, officers, employees, agents or volunteers shall be at Contractor's own cost, expense and risk. Contractor shall pay and satisfy any judgment, award or decree that may be rendered against District or its officials, officers, employees, agents or volunteers, in any such suit, action or other legal proceeding. Contractor shall reimburse District and its officials, officers, employees, agents and/or volunteers, for any and all legal expenses and costs incurred by each of them in connection therewith or in enforcing the indemnity herein provided.

- C. Contractor's obligation to indemnify shall not be restricted to insurance proceeds, if any, received by the District, its officials, officers, employees, agents or volunteers.

Section 14 - Insurance.

- A. General. Contractor shall take out and maintain:
 - 1. Commercial General Liability Insurance, of at least \$1,000,000 per occurrence/ \$2,000,000 aggregate for bodily injury, personal injury and property damage;
 - 2. Automobile Liability Insurance for bodily injury and property damage including coverage for owned, non-owned and hired vehicles, of at least \$1,000,000 per accident for bodily injury and property damage;
 - 3. Workers' Compensation in compliance with applicable statutory requirements; and
 - 4. If Contractor is also the manufacturer of any equipment included in the Equipment, Contractor shall carry Product Liability and/or Errors and Omissions Insurance which covers said equipment with limits of not less than \$1,000,000.
- B. Additional Insured; Primary; Waiver of Subrogation; No Limitation on Coverage. The policies required under this Section shall give District, its officials, officers, employees, agents or volunteers additional insured status. Such policies shall contain a provision stating that Contractor's policy is primary insurance and that any insurance, self-insurance or other coverage maintained by the District or any additional insureds shall not be called upon to contribute to any loss, and shall contain or be endorsed with a waiver of subrogation in favor of the District, its officials, officers, employees, agents, and volunteers. The limits set forth herein shall apply separately to each insured against whom claims are made or suits are brought, except with respect to the limits of liability. Requirements of specific coverage or limits contained in this section are not intended as a limitation on coverage, limits, or other requirement, or a waiver of any coverage normally provided by any insurance. Any available coverage shall be provided to the parties required to be named as additional insured pursuant to this Agreement.
- C. Insurance Carrier. All insurance required under this Section is to be placed with insurers with a current A.M. Best's rating no less than A-VII, licensed to do business in Nevada, and satisfactory to the District.
- D. Evidence of Insurance. Contractor shall furnish District with original certificates of insurance and endorsements effecting coverage required by the Agreement. The certificates and endorsements for each insurance policy shall be signed by a person authorized by that insurer to bind coverage on its behalf, and shall be on forms supplied or approved by the District. All certificates and endorsements must be received and approved by the District before delivery commences. The District

reserves the right to require complete, certified copies of all required insurance policies, at any time.

- E. Subcontractors. All subcontractors shall meet the requirements of this Section before commencing work. In addition, Contractor shall include all subcontractors as insureds under its policies or shall furnish separate certificates and endorsements for each subcontractor. All coverages for subcontractors shall be subject to all of the requirements stated herein.
- F. Freight. Contractor shall ensure that third party shippers contracted by Contractor have adequate insurance coverage for the shipped Equipment.

Section 15 - Liens.

- A. Contractor, subcontractors and suppliers will not make, file or maintain a mechanic's or other lien or claim of any kind or character against the Equipment, for or on account of any labor, materials, fixtures, tools, machinery, equipment, or any other things furnished, or any other work done or performance given under, arising out of, or in any manner connected with the Agreement (such liens or claims referred to as "Claims"); and Contractor, subcontractor and suppliers expressly waive and relinquish any and all rights which they now have, or may subsequently acquire, to file or maintain any Claim and Contractor, subcontractor and suppliers agree that this provision waiving the right of Claims will be an independent covenant.
- B. Contractor will save and hold District harmless from and against any and all Claims that may be filed by a subcontractor, supplier or any other person or entity and Contractor will, at its own expense, defend any and all actions based upon such Claims and will pay all charges of attorneys and all costs and other expenses arising from such Claims.

Section 16 - Termination of Agreement by District.

- A. Should Contractor at any time refuse or fail to deliver the Equipment with promptness and diligence, or to perform any of its other obligations under the Agreement, District may terminate Contractor's right to proceed with the delivery of the Equipment by written notice to Contractor. In such event District may obtain the Equipment by whatever method it may deem expedient, including the hiring of another contractor or other contractors and, for that purpose, may take possession of all materials, machinery, equipment, tools and appliances and exercise all rights, options and privileges of Contractor. In such case Contractor will not be entitled to receive any further payments until the Equipment is delivered. If District's cost of obtaining the Equipment, including compensation for additional managerial and administrative services, will exceed the unpaid balance of the Agreement, Contractor will be liable for and will pay the difference to District.
- B. District may, for its own convenience, terminate Contractor's right to proceed with the delivery of any portion or all of the Equipment by written notice to Contractor.

Such termination will be effective in the manner specified in such notice, will be without prejudice to any claims which District may have against Contractor, and will not affect the obligations and duties of Contractor under the Agreement with respect to portions of the Equipment not terminated.

- C. On receipt of notice under Section 16 - B, Contractor will, with respect to the portion of the Equipment terminated, unless the notice states otherwise,
 - 1. Immediately discontinue such portion of the Equipment and the placing of orders for materials, facilities, and supplies in connection with the Equipment,
 - 2. Unless otherwise directed by District, make every reasonable effort to procure cancellation of all existing orders or contracts upon terms satisfactory to District; and
 - 3. Deliver only such portions of the Equipment which District deems necessary to preserve and protect those portions of the Equipment already in progress and to protect material, plant and equipment at the Equipment site or in transit to the Equipment site.

- D. Upon termination pursuant to Section 16 - B, Contractor will be paid a pro rata portion of the compensation in the Agreement for any portion of the terminated Equipment already delivered, including material and services for which it has made firm contracts which are not canceled, it being understood that District will be entitled to such material and services. Upon determination of the amount of said pro rata compensation, District will promptly pay such amount to Contractor upon delivery by Contractor of the releases of liens and affidavit, pursuant to Section 7 - C.

Section 17 - Miscellaneous Provisions.

- A. Assignment or Transfer. Contractor shall not assign or transfer any interest in this Agreement whether by assignment or novation, without the prior written consent of the District, which will not be unreasonably withheld. Provided, however, that claims for money due or to become due Contractor from the District under this Agreement may be assigned to a financial institution or to a trustee in bankruptcy, without such approval. Notice of any assignment or transfer, whether voluntary or involuntary, shall be furnished promptly to the District.

- B. Successors and Assigns. This Agreement shall be binding on the successors and assigns of the Parties.

- C. Amendment; Modification. No supplement, modification or amendment of this Agreement shall be binding unless executed in writing and signed by both Parties.

- D. Waiver. No waiver of any default shall constitute a waiver of any other default or breach, whether of the same or other covenant or condition. No waiver, benefit,

privilege or service voluntarily given or performed by a Party shall give the other Party any contractual rights by custom, estoppel or otherwise.

- E. Governing Law. This Agreement shall be governed by the laws of the State of Nevada. Venue shall be in Washoe County.
- F. Interpretation. Since the Parties or their agents have participated fully in the preparation of this Agreement, the language of this Agreement shall be construed simply, according to its fair meaning, and not strictly for or against any Party.
- G. No Third Party Beneficiaries. There are no intended third party beneficiaries of any right or obligation assumed by the Parties.
- H. Authority to Enter Agreement. Each Party warrants that the individuals who have signed this Agreement have the legal power, right and authority to make this Agreement and bind each respective Party.
- I. Invalidity; Severability. If any portion of this Agreement is declared invalid, illegal or otherwise unenforceable by a court of competent jurisdiction, the remaining provisions shall continue in full force and effect.
- J. Counterparts. This Agreement may be signed in counterparts, each of which shall constitute an original.
- K. District's Right to Employ Other Contractors. District reserves its right to employ other contractors in connection with the Equipment.
- L. Entire Agreement. This Agreement constitutes the entire agreement between the Parties relative to the Equipment specified herein. There are no understandings, agreements, conditions, representations, warranties or promises with respect to this Agreement, except those contained in or referred to in the writing.
- M. Limitation of Liability. In no event shall this Agreement be interpreted to waive the limitations of liability applicable to the District set forth in NRS Chapter 41 or other applicable law.

IN WITNESS WHEREOF, the parties hereto have set their hands the day and date of the year first set forth above.

OWNER:
INCLINE VILLAGE G. I. D.
Agreed to:

Contractor:
STAR LIFTS USA
Agreed to:

By: _____
Mike Bandelin
Diamond Peak General Manager

By: _____
Signature of Authorized Agent

Print or Type Name and Title

Date

Date

Approved as to Form:

Joshua Nelson
District General Counsel

If Contractor is a corporation, attach evidence of authority to sign.

Date

Owner's address for giving notice:
INCLINE VILLAGE G. I. D.
893 Southwood Boulevard
Incline Village, Nevada 89451
775-832-1267- Engineering Division

Contractor's address for giving notice:
Star Lifts USA
PO Box 798
Sunapee, New Hampshire 03782
603-863-0241



**INCLINE VILLAGE GENERAL IMPROVEMENT DISTRICT (IVGID)
dba
DIAMOND PEAK SKI RESORT
REQUEST FOR PROPOSALS
Diamond Peak Ski Resort Conveyor Surface Lift Procurement**

July 12, 2021

SECTION 1 – REQUEST FOR PROPOSALS

Sealed proposals will be received at the offices of the Engineering Division, Incline Village General Improvement District (IVGID or District), 1220 Sweetwater Road, Incline Village, Nevada 89451, until **3:00 p.m., July 22, 2021**, at which time they will be publicly opened and read for:

Diamond Peak Ski Resort Conveyor Surface Lift Procurement

IVGID is accepting proposals to provide one (1) new Surface Conveyor Lift for use at the District's Diamond Peak Ski Resort.

Complete Proposal Documents may be obtained at the IVGID Engineering office, or downloaded from our website, at <https://www.yourtahoeplace.com/ivgid/resources/purchasing>. It is the Bidder's sole responsibility to obtain a complete set of documents.

All proposals will be evaluated by District Staff for responsiveness in accordance with the Proposal Evaluation Checklist, which is included with the Proposal Documents. Following this evaluation, District Staff will make a recommendation to the IVGID Board of Trustees at its next regularly scheduled Board Meeting, anticipated to be on August 10, 2021, to award a procurement contract to the most qualified lowest responsive bidder.

The District reserves the right to reject any or all proposals and to waive any irregularities therein.

To request a copy of the Proposal Documents or if you have any questions concerning this procurement bid, contact the District Engineering Office at 775-832-1267.

SECTION 2 INSTRUCTIONS AND GENERAL CONDITIONS

A. GENERAL PROPOSAL INFORMATION

1. SCOPE AND INTENT:

It shall be the intent of this Invitation to Bid to select a vendor(s) to provide one (1) conveyor surface lift for the District's Diamond Peak Ski Resort meeting the technical specifications included herein. The merchandise proposed shall be the model in manufacturer's product line that best meets the intent of the technical specifications. Diamond Peak Ski Resort shall utilize the conveyor surface lift to transport skiers and snowboarders at the ski resort. These bid specifications are intended to set minimum acceptable standards for such merchandise.

2. PROPOSAL RESPONSES: It is assumed that all responses to this proposal specification are on behalf of the Bidder acting either as an authorized dealer or distributor for the manufacturer



of the items being proposed and that these responses are supplied by the manufacturer. If this is not the case, Bidder shall explain, in writing in a statement to be enclosed with the proposal.

3. **PROPOSAL EVALUATION:** All proposals will be evaluated to determine the most qualified lowest responsive proposal. Proposal exceptions are permissible, provided that what the Bidder is offering meets the intent of the proposal specifications, as determined by the Buyer. Proposals will be weighted on Section 3.

B. SUBMISSION OF PROPOSALS

1. Proposals shall be submitted in a **sealed opaque envelope**, with the outside clearly marked as follows:

"Diamond Peak Conveyor Surface Lift Bid"

- Bidders are cautioned to mark their envelopes clearly and plainly. If the envelope is not so marked and the Proposal is opened by mistake prior to the specified date and time, the Proposal will **NOT** be considered.
 - All Proposals must be sealed. Proposals submitted unsealed, by telephone, email or facsimile will **NOT** be accepted.
2. Sealed proposals will be received at the offices of the IVGID Engineering Division, 1220 Sweetwater Road, Incline Village, Nevada 89451, until the date and time specified in Section 1, at which time they will be publicly opened and read.
 3. Late, incomplete or unsigned Proposals shall receive no consideration.
 4. Proposals shall be made on the forms provided herein and all blank spaces in the forms shall be filled in. The Bidder or an authorized agent must sign all Proposals.
 5. The District assumes no responsibility for errant delivery of Proposals, including those relegated to a courier agent who fails to deliver in accordance with the time and receiving point specified.
 6. Proposals may be withdrawn by written notice, provided the notice of withdrawal is received prior to the Proposal opening time.
 7. Proposals are subject to acceptance at any time within sixty (60) days after the Proposal opening.
 8. Prices must be stated in units specified. Prices for initial purchase quantities must be effective until delivery.
 9. Prices quoted must be exclusive of Federal and State taxes, as IVGID is exempt from such taxes.

C. DELIVERY INFORMATION:

1. Shipping is FOB Destination. Merchandise purchased shall be delivered to the Diamond Peak Ski Resort preferably no later than November 1, 2021. Bidder to list alternately-proposed delivery date in the Bid Form, if after said date. Diamond Peak is located at 1210 Ski Way, Incline Village, Washoe County, Nevada 89451. Exception 1
2. Liquidated Damages: Supplier and IVGID recognize that time is of the essence with this procurement and that the District will suffer financial loss if delivery of the Conveyor Surface

Lift is not completed within the time specified in Paragraph C.1., above, or as may be agreed upon in awarded Purchase Agreement, based on proposed delivery date provided with Bid. The parties also recognize the delays, expense and difficulties involved in proving in a legal or arbitration proceeding the actual loss suffered by the District if the Conveyor Surface Lift are not received in time. Accordingly, instead of requiring any such proof, District and Supplier agree that, as liquidated damages for delay (but not as a penalty), Supplier shall pay District \$100 for each day that expires after the time specified in Paragraph C.1., above, until all merchandise is delivered.

D. COMPLETE PROPOSAL PACKAGE:

1. A complete Proposal shall include this document, pages 1 through 7 inclusive, together with the following:
 - a. Warranty information per Section 5 of this Proposal Package Exception 2
 - b. A guarantee to provide 24-hour service/technical support during our operating season.
2. To aid in the proposal evaluation process, the proposal package submitted by Bidder should also include product specifications, brochures, pictures and other support data for the merchandise proposed.

F. FIRM PRICING REQUIRED: Prices submitted shall remain firm for all deliveries specified in this Invitation and Proposal. For any additional orders, bidders shall guarantee their prices for a minimum of one (1) year from proposal award exclusive of itemized shipping costs. District reserves the right to purchase additional items at any point during the three (3) year product availability guarantee.

Exception 3

G. EXCEPTIONS:

1. Proposals shall note any and all exceptions to the specifications and/or the terms and conditions that are contained herein.
2. All exceptions to the proposal must be stated in writing on the Proposal Form, so that they may be considered. If exceptions are not stated, it will be assumed that the bidder meets all requirements.

H. DAMAGED GOODS: Damaged goods shall be replaced by the successful bidder at no cost to the District, whether damage is observed at time of delivery or upon the unpacking of the equipment. District is to notify supplier within 2 weeks of discovery of any damaged or faulty goods. Such notice shall be provided in writing.

I. TERMS AND CONDITIONS: Bidders shall be aware of, and agree to abide by, the terms and conditions contained in this Invitation and Proposal.

J. OPEN MEETING LAW: The Incline Village General Improvement District shall adhere to NRS 241 which provides that public business shall be conducted in an open meeting.

K. DISCLOSURE OF PRINCIPALS: Bidders shall complete and return with their Proposal response, the attached copy of the form titled "Disclosure of Principals."



- L. **ACCEPTANCE AND/OR REJECTION OF PROPOSALS:** IVGID agencies shall reserve the right to accept or reject any or all resultant proposal response, or parts thereof, including but not necessarily limited to, alternatives offered. Such acceptance and/or rejection shall be based solely on the considered value of such offers to the District.

SECTION 3 PROPOSAL EVALUATION CHECKLIST

- A. Proposals shall be reviewed for responsiveness by District staff on the following parameters:
- Conformance to the Specifications
 - Unit cost
 - Warranty
 - Defined Exceptions

SECTION 4 SURFACE CONVEYOR LIFT TECHNICAL SPECIFICATIONS:

A. GENERAL INFORMATION

All proposals will be evaluated by District Staff for responsiveness in accordance with the Proposal Evaluation Checklist included in Section 3. Following this evaluation, District Staff will make a recommendation to the IVGID Board of Trustees at its next regularly scheduled Board Meeting, anticipated to be on **August 10, 2021**, to award a procurement contract to the lowest responsive qualified bidder.

B. REQUIREMENTS/EXPECTATIONS OF SURFACE CONVEYOR LIFT

- Conveyor shall be constructed to meet the ANSI B77.1 - 2017 Standards. Successful Bidder shall provide Engineering submittals and certifications showing compliance with ANSI B77.1 - 2017
- Conveyor shall accommodate a desired travel length of 50' (15.24 meters)
- Conveyor belt shall be a minimum of 24" (610 mm) wide and be equipped with a mechanical splice
- Special tools required for service of conveyor and belt splice shall be included
- Conveyor shall be equipped with walkways of a minimum 18" (457 mm) in width
- Conveyor shall be equipped with a desired top drive and bottom return terminal
- Conveyor mid-sections shall be equipped with a galvanized finish
- Conveyor belt tensioning system shall be equipped with a **hydraulic tensioning mechanism or equivalent.** ← Exception 4
- Conveyor shall be equipped with a variable frequency drive designed for a 480VAC 60 Hz 3-ph power supply
- Conveyor belt shall be capable of a speed of 0.8 m/s (160 fpm)
- Conveyor low voltage control system shall be equipped with a fault annunciation panel and certified as a UL industrial control panel or equivalent

- Conveyor shall be equipped with an exterior mounted drive control cabinet
- A detailed operation and maintenance manual must be provided
- Conveyor shall be equipped with an additional Stop including a 20' cord and quick connect plug to control cabinet
- Height adjustable support jacks shall be included per design specifications

Bidder should list any optional equipment and pricing to the proposed surface conveyor lift on their proposal.

Bidders may submit multiple separate bid proposals for additional products that they feel may meet or exceed these bid specifications.

SECTION 5 PRODUCT WARRANTY

- A. **General:** All warranty offerings from the manufacturer shall cover the quality of labor, workmanship and materials that go into the combination of components that make up the complete equipment. Warranty conditions and limitations considered standard in this equipment's manufacturing industry are acceptable.

As a condition of product final acceptance, all warranties offered from all manufacturers shall be available in written form and be included, properly filled out, with the merchandise when delivered. All warranties shall be directly from the appropriate manufacturer of that portion of the merchandise, and not modified or backed by a subsequent manufacturer who performed work on the merchandise at a later stage in the manufacturing process.

- B. **Basic Warranty:** Total shall be covered for materials and workmanship for a minimum of one (1) year from the date of the Buyer's first use.

Exception 5

All warranty work required during the operating season shall be completed in a time period not to exceed two (2) weeks. All warranty work stated above shall be at no cost to IVGID, including materials, labor, travel time, and travel expense and/or equipment transportation.



SECTION 6 PROPOSAL FORM

Multiple bids may be submitted based on Bidder's proposed equipment, and must be provided separately, using additional copies of this Form.

The undersigned vendor shall provide a new Surface Conveyor Lift meeting the specifications listed in the Request for Proposals dated July 12, 2021.

A price should be stated in both numbers and in words in the spaces provided on this form.

Proposals returned on a form other than this one will not be accepted.

Description	Bid Price in Numbers	Bid Price in Words
Surface Conveyor Lift	\$ 49,995.00	Forty Nine Thousand Nine Hundred
		Ninety Five and no cents

Bidder can meet the required November 1, 2021 delivery date: Yes No
 If "No," what delivery date does Bidder propose: See Exception 1

Describe Any Optional Equipment Proposed	Bid Amount
'Blue-Eye' belt surface in lieu of 'Rufftop' belt surface	\$ 1,640.00 additional
Rotating powered snow brush to clean belt surface	\$ 1,320.00 additional
Drive drum surface hot air blower system	\$ 2,610.00 additional
	\$
	\$
	\$

Exceptions (attached additional pages if necessary): See attached page with 10 exceptions

Firm Name: Star Lifts USA, Inc.

Signature of Bidder: 

Date: July 20, 2021 Phone # (603) 863-0241

Title: Vice President Email: conor@starlifts.com



SECTION 7 DISCLOSURE OF PRINCIPALS

PRINT OR TYPE:

Firm Name: Star Lifts USA
Address: PO Box 798
City, St, Zip: Sunapee, NH 03782
Date Business Started: 1998
Principal Address of Company: PO Box 798, 52 Depot Rd
Sunapee, NH 03782

NAMES OF OFFICERS, MEMBERS, OR OWNERS OF CONCERN, PARTNERSHIP

Name: Emanuel Wohlfarter Official Capacity: President
Address: PO Box 798, 52 Depot Rd, Sunapee, NH 03782

Name: Conor Rowan Official Capacity: Vice President
Address: PO Box 798, 52 Depot Rd, Sunapee, NH 03782

Name: _____ Official Capacity: _____
Address: _____

END OF PROPOSAL DOCUMENT



22 July 2021

EXCEPTIONS TO IVGID dba DIAMOND PEAK SKI RESORT RFP FOR CONVEYOR LIFT dated 12 July 2021:

1. Section 2.Paragraph C.1 (Alternately-proposed delivery date): Equipment shall be delivered within 18 weeks (126 days) of the date that the procurement contract is awarded.
2. Section 2. Paragraph D.1.b (Service/technical support): The service guarantee shall be from 8 AM to 5 PM (local time at Diamond Peak), including weekends and holidays, during the winter operating season.
3. Section 2. Paragraph F (Price guarantee): Pricing for any additional orders beyond the (1) conveyor shall be guaranteed for a maximum of 60 days from the proposal award.
4. Section 4. Paragraph B (Conveyor belt tensioning system): The conveyor belt tensioning system shall be equipped with a equivalent 'dual screw thread tensioning with tension force indicator'. (This system has been proven in service for conveyors up to 200 ft length since 2001).
5. Section 5. Paragraph B (Warranty length): Total shall be covered for materials and workmanship for a minimum of two (2) years from the date of delivery of the conveyor.
6. The RFP does not include (must be supplied by Buyer):
 - Off-loading equipment from trucks or out of containers upon arrival at ski area.
 - Ground profile survey, design layout, snow vault design.
 - Any costs in connection with government or authority having jurisdiction permits.
 - Any additional engineering or submittals required for obtaining local building permits.
 - Any required signs, fencing, or other materials for operational requirements.
 - Communications system and/or related wiring between the top and bottom terminals.
 - External grounding, GFI, and/or lightning protection.
 - Material or labor for any anchorages, foundations, cribbing, snow vaults, or enclosure anchorages.
 - Assembly and construction (mechanical or electrical) of conveyor, wind anchors, foundations, snow-pits, or skirting.
 - Material or labor to supply 480V 3 phase power to SunKid control cabinet on drive terminal (including sourcing and installing isolation or step-down transformer, if required).
7. Scope of engineering work under this RFP is limited to:
 - Verification of conveyor equipment design conformance to the ANSI B77-2017 Standard.
 - Development of the Acceptance Testing procedures.
 - Attendance during the Acceptance Testing.
 - Verification of construction in accordance with the conveyor equipment drawings and specifications.
 - Verification of electrical system acceptance test.
 - Delivery of Acceptance Testing results including software security procedures.
8. Guarding: Buyer shall make provisions to keep the public away from the return belt and any moving components other than the up-going belt.
9. Force Majeure: No party shall be responsible to the other party for delay or failure in performance of any the obligations imposed by this Agreement, provided such failure shall be occasioned by fire, flood, explosion, lightning, wind storm, hailstorm, earthquake, failure of machinery or equipment or supply of materials, court order or governmental interference, terrorist attacks, civil commotion, riot, war, strikes, labor disturbances, transportation difficulties, labor shortage, or by any other cause of like or unlike nature beyond the reasonable control and without fault or negligence of such party.
10. Full payment due upon delivery of conveyor to Diamond Peak Ski Resort (net 30).



**Proposal for 50 ft
Snow School Conveyor
At Diamond Peak Ski Resort, NV
(belt conveyor)**



22 July 2021



Prepared for: **InclineVillage GID dba
Diamond Peak Ski Resort**
1210 Ski Way
Incline Village, NV 89451

Description	Total (USD):
<p><u>50-ft SunKid Conveyor with 'Endless Belt' technology:</u> (1450 pph @ 0.8m/s (160 fpm) at 6.6 ft spacing and <15% avg. grade)</p> <ul style="list-style-type: none"> o Top Drive terminal consisting of a 'Standard' drive terminal w/ a 3.0 kW (5 hp) gearmotor drive, 180 mm drive drum, hinged terminal covers, and ABB variable frequency drive designed for 480VAC 60 Hz 3-ph power supply. o Exterior mounted pedestal drive control cabinet w/ SunKid foam cover. o Low voltage control system with fault annunciation panel, Pluto S20 safety PLC, Mitsubishi fault annunciation PLC, Adam safety sensor monitored transition stop gate & step plate, and start warning tone. Panel is cUL certified as Industrial Control Panel. o Bottom Return terminal with 'Standard' return terminal with screw thread tensioning, 200 mm (8") return drum, and adjustable inclined entrance ramp. o Hinged & quick removable panels for easy top entry access to the Drive and Return Terminals. o 24"-wide 400/3-ply belting <ul style="list-style-type: none"> • "Rufftop" standard belt surface • Mechanical splices (RS187) o 'Type-G' galvanized midsections 3m long (~10-ft) w/ belt edge guides. (qty. 4) <ul style="list-style-type: none"> • Superslide smooth HDPE belt running surface • Walkways (18" wide) w/ belt edge guides & fleece covering between belt edge guides and Gallery enclosure walls. • Open-bottom frame to eliminate snow and ice from being trapped within the conveyor machinery. • 12" adjustable staging jacks every 3 m (10 ft) for fine tune leveling. o Basic Maintenance package that includes 4x 24" splice rods, Adam safety switch, proximity sensor, basic hand tools, and belt clamping & pulling system for splicing. o Designed and built to meet the ANSI B77.1-2017 Standard. o Engineering Submittals and certifications showing compliance with ANSI B77.1-2017 Standard. o Delivered DDP Diamond Peak, NV base area parking lot per Incoterms 2010. 	<p>\$ 49,995.00</p>
<p>Options:</p> <p>"Blue-Eye" Belt surface w/ soft rubber dots on a hard rubber primary belt: superior user traction, and improved snow shedding performance in lieu of 'Rufftop' belt surface-ADD:</p> <p>Rotating Snow Brush to clean belt surface (powered by separate gearmotor)-ADD:</p> <p>Drive Drum Surface Hot Air Blower System for minimizing drum glazing-ADD:</p>	<p>+ \$ 1,640.00</p> <p>+ \$ 1,320.00</p> <p>+ \$ 2,610.00</p>

Preliminary

07/20/2021 6:52:15 AM

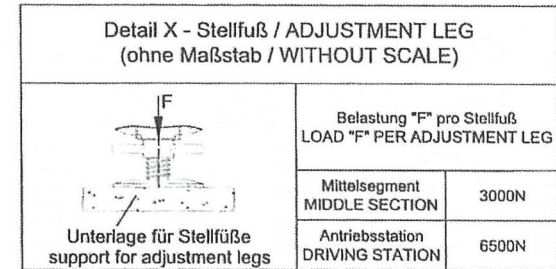
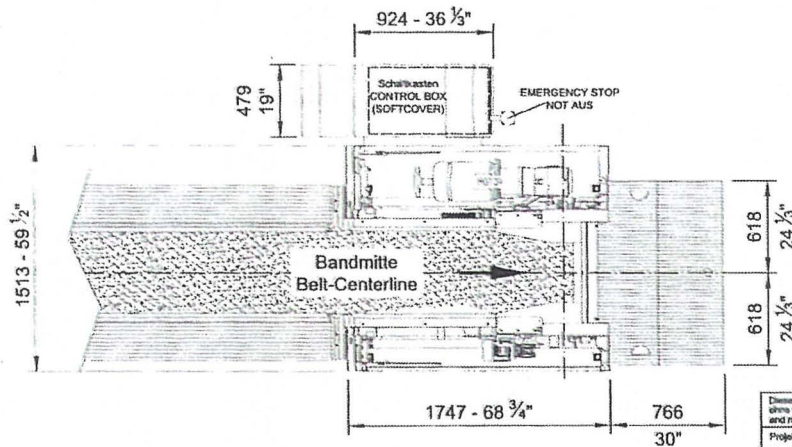
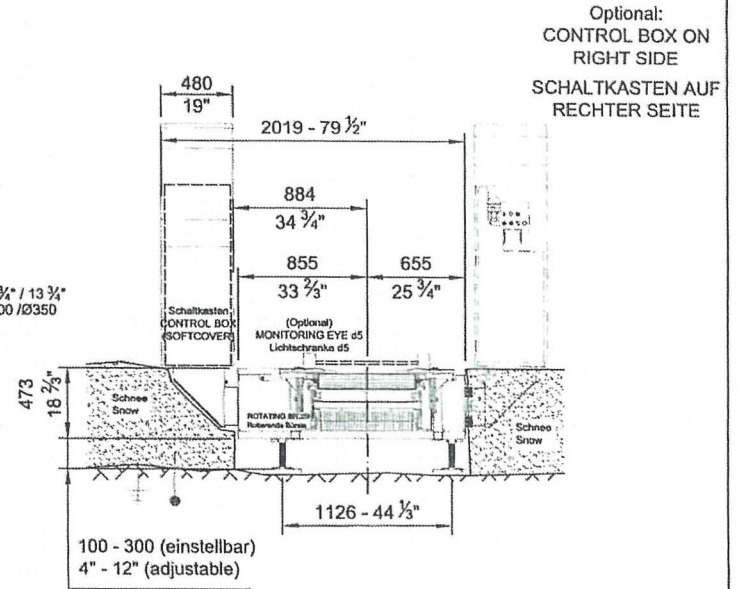
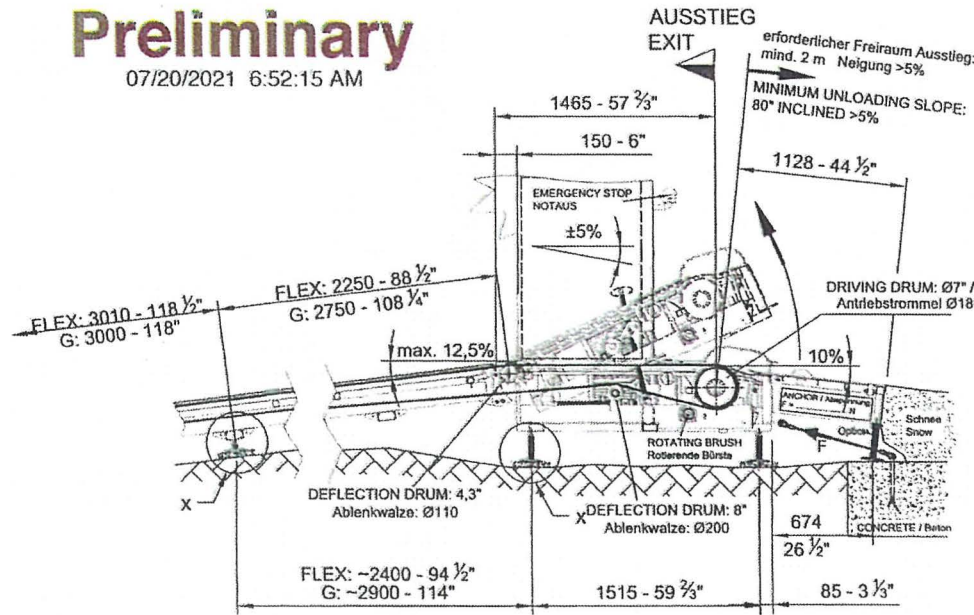

MASSE IN MM
MEASURES IN MM

<p>Diese Unterlagen sind Eigentum der Firma Bruckschlägl GmbH, 4822 Bad Gleern und dürfen als Ganzes oder teilweise weiterverfüttert noch Dritten, zugänglich gemacht werden ohne die schriftliche Zustimmung der Eigentümer. Zuwiderhandlungen verpflichten zu Schadenersatz. / These documents remain the sole property of Bruckschlägl GmbH, 4822 Bad Gleern and must not be copied or reproduced in whole or in part or made available to third parties without written permission from the owners. Violation obligates compensation for damages.</p>			
<p>Projektprojekt: Antriebsstation 2,2 - 11kW Ausstieg + Abspannung DRIVE STATION 2,2 - 11kW EXIT + ANCHOR</p>	<p>Hersteller/Manufacturer: BRUCKSCHLÖGL GEM. M.B.H. MANCHINENFABRIKENTECHNOLOGIEN A-4822 Bad Gleern, www.bruckschlaegl.com / tel 132</p>	<p>Produkt/product: SUNKID ZAUBERTEPPICH SUNKID MOVING CARPET</p>	<p>Revisions/Modif. range: SKD 26 Datum/Date: 28.01.2021</p>
<p>entwurf durch: created by: -</p>	<p>Anspruchspartner: Responsibility/Spec: -</p>	<p>Detail/Details: Endlosband - 600mm breit/BELT - 24" WIDE</p>	<p>Maßstab/ Scale: 1:30 (A3) Seiten/Pages: 1/1</p>
<p>entwurf mit AutoCAD LT 2014</p>		<p>EDV Nr.: m21-10-101.dwg</p>	

Preliminary

07/20/2021 6:52:31 AM

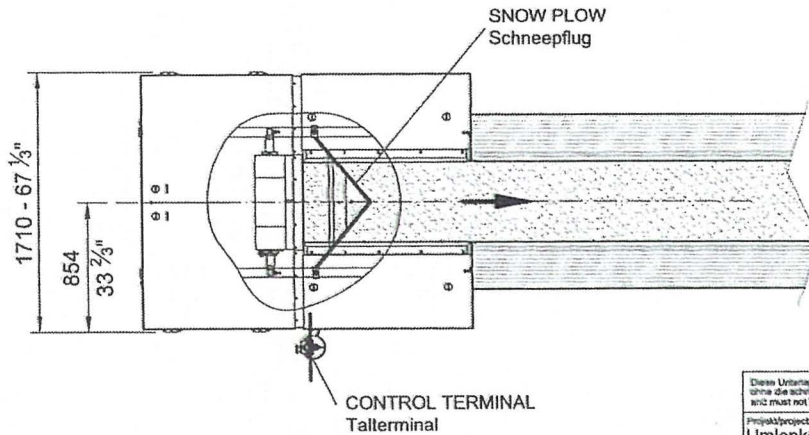
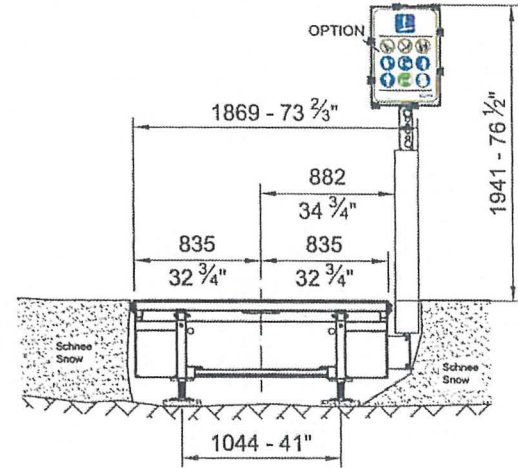
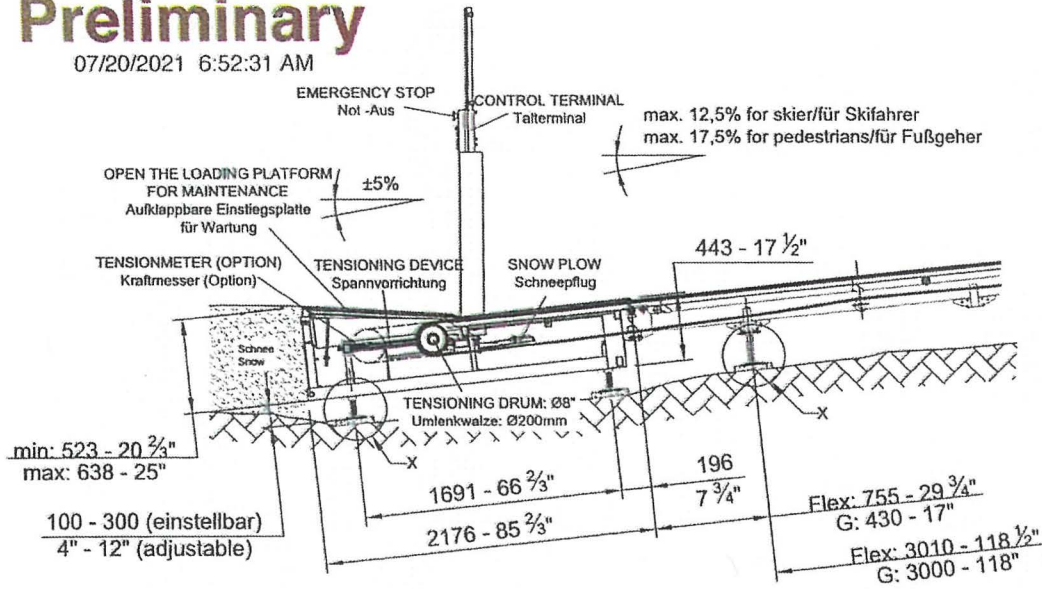

Detail X - Stellfuß / ADJUSTMENT LEG
(ohne Maßstab / WITHOUT SCALE)

<p>Unterlage für Stellfüße support for adjustment legs</p>	Belastung "F" pro Stellfuß LOAD "F" PER ADJUSTMENT LEG	
	Mittelsegment MIDDLE SECTION	3000N
	Umlenkstation RETURN STATION	2500N

MASSE IN MM
MEASURES IN MM

<p>Diese Unterlagen sind Eigentum der Firma Bruckschlögl GmbH, 4822 Bad Gleichen und dürfen als Ganzes oder teilweise weder vervielfältigt noch Dritten zugänglich gemacht werden ohne die schriftliche Zustimmung der Eigentümer. Zuwiderhandlungen verpflichten zu Schadenersatz. / These documents remain the sole property of Bruckschlögl GmbH, 4822 Bad Gleichen and must not be copied or reproduced in whole or in part or made available to third parties without written permission from the owners. Violation obligates compensation for damages.</p>			
<p>Projekt/Project: Umlenkstation Standard RETURN STATION STANDARD and LOADING AREA</p>	<p>Hersteller/Manufacturer: BRUCKSCHLÖGL GEM.B.H. MASCHINENBAU / ORIENTECHNIK GEB. BAU / TECH. WK. A-4822 Bad Gleichen am Hallstättersee / P. 132</p>	<p>Produkt/Product: SUNKID ZAUBERTEPPICH SUNKID MOVING CARPET</p>	<p>Skizzen-/ Model range: SKP.26</p>
<p>erstellt durch: Created by: LP</p>	<p>Konstruktions-/ Designed by: MRO</p>	<p>Details/Details: Endlosband - 600mm breit / BELT - 24" WIDE</p>	<p>Datum/Date: 01.02.2021</p>
<p>erstellt mit AutoCAD LT 2014</p>	<p>EDV Nr.: m21-10-201_8600.dwg</p>	<p>Maßstab/ Scale: 1:30 (A3)</p>	<p>Seite/Pages: 1/1</p>

Preliminary

07/20/2021 6:52:03 AM

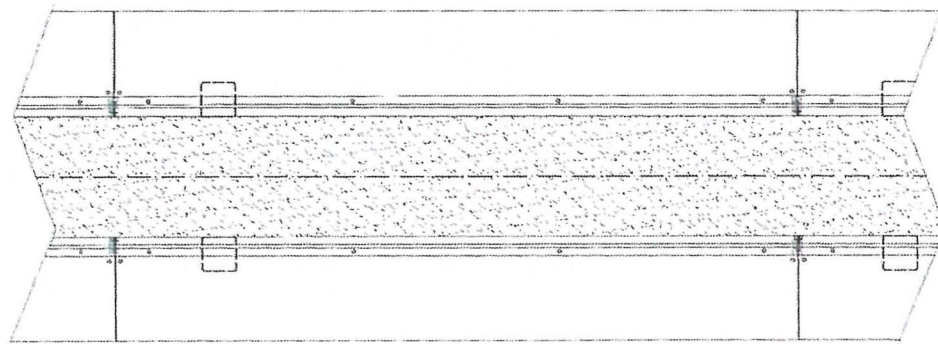
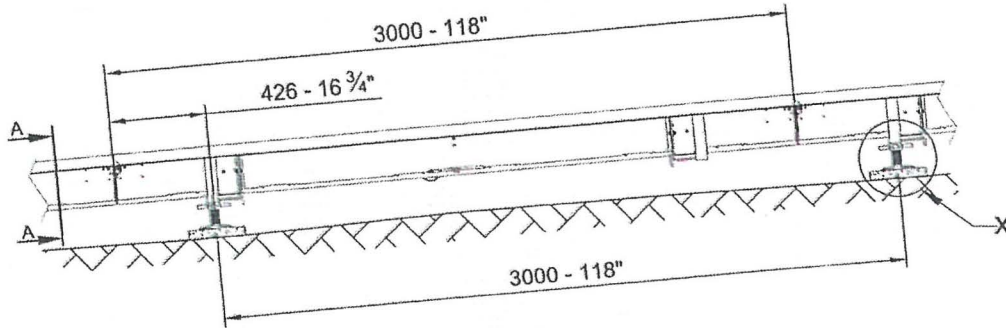

Querschnitt A-A (Maßstab 1:15)
CROSS SECTION A-A (SCALE 1:15)

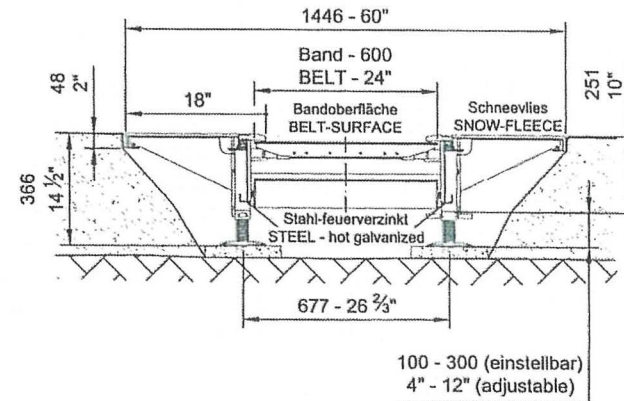

Optional ohne Abdeckung
(Maßstab 1:10)
OPTIONAL WITHOUT
WALKWAY DESIGN
(SCALE 1:10)

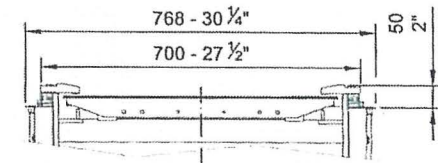

Detail X - Stellfuß / ADJUSTMENT LEG
(ohne Maßstab / WITHOUT SCALE)

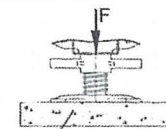

Unterlage für Stellfüße
support for adjustment legs

Belastung "F" pro Stellfuß
LOAD "F" PER ADJUSTMENT LEG

Mittelsegment
MIDDLE SECTION

3000N

Diese Unterlagen sind Eigentum der Firma Bruckschlögl GmbH, 4822 Bad Gleernberg und dürfen als Ganzes oder teilweise weder ververvielfältigt noch Dritten personen zugänglich gemacht werden ohne die schriftliche Zustimmung der Eigentümer. Zuwiderhandlungen verpflichten zu Schadenersatz. / These documents remain the sole property of Bruckschlögl GmbH, 4822 Bad Gleernberg and must not be copied or reproduced in whole or in part or made available to third parties without written permission from the owners. Violation obligates compensation for damages.

Projekt/project: Mittelsegment Type G 18 Zoll - Abdeckung MIDDLE SECTION TYPE G 18 INCH - COVER		Hersteller/Manufacturer: BRUCKSCHLÖGL GEB. M.B.H. MASCHINENBAU FÜR DEUTSCHEN GELBEINTECHNIK A-4822 Bad Gleernberg im Hublbergwerk / No.132		Produkt/product: SUNKID ZAUBERTEPPICH SUNKID MOVING CARPET		Baureihe/ Model range SKD 26	
erstellt durch created by: LP		Ansprechpartner/ Representative: MO		Details/details: Endlosband - 600mm breit/BELT - 24" WIDE		Datum/Date 01.02.2021	
erstellt mit AutoCAD LT 2014		EDV Nr.: m21-10-301_1BZ.dwg		Maßstab/ Scale 1:20 (A3)		Seiten/Pages 1/1	

MASSE IN MM
MEASURES IN MM



Project Summary

Project Number:	3467LE1703
Title:	Replace Child Ski Center Surface Lift
Project Type:	D - Capital Improvement - Existing Facilities
Division:	67 - Child Ski Center
Budget Year:	2022
Finance Option:	
Asset Type:	HE - Heavy Duty Service Equipment
Active:	Yes

Project Description				
This project describes the procurement and replacement of the original 1997 Surface Lift at Diamond Peak located within the Child Ski Center Program learning area.				
Project Internal Staff				
Mountain and Operations staff will oversee the selection and procurement and installation of the equipment.				
Project Justification				
The Diamond Peak Child Ski Center offer ski lessons to our customers and community programs to Children ages 3 -7 years old. The learn to ski program is designed with children using the Surface Lift in the lesson prior to the progression of ridding the Schoolhouse lift. The current surface lift was purchased and installed in 1997 and is due for replacement as the equipment and machinery is nearing the end of its useful life. The general purpose of this project is to improve our facilities through required maintenance and replacement improvements that directly or indirectly reflect on our guest's experience. This project is designed to maintain the value of the Diamond Peak Ski Resort asset and customer service.				
Forecast				
Budget Year	Total Expense	Total Revenue	Difference	
2022				
Child Ski Center Surface Lift	75,000	0	75,000	
Year Total	75,000	0	75,000	
	75,000	0	75,000	
Year Identified	Start Date	Est. Completion Date	Manager	Project Partner
2017	Jul 1, 2021	Jun 30, 2022	Ski Resort General Manager	



INCLINE VILLAGE GENERAL IMPROVEMENT DISTRICT

PURCHASE ORDER

P.O. NUMBER	DATE
22-0053	08/02/2021

THIS NUMBER MUST APPEAR ON ALL INVOICES PACKING LISTS, LABELS, BILLS OF LADING AND CORRESPONDENCE

Vendor Name, Address, and Number	Ship To Address And Phone Number	Please Send Invoices To
2498 Star Lifts USA, Inc P.O. Box 798 Sunapee, NH 03782	 775-832-1100	Incline Village GID 893 Southwood Blvd. Incline Village, NV 89451 75-832-1100 ap@ivgid.org

*** This is Not an Approved PO ***

LINE NO.	QUANTITY	UOM	ITEM AND DESCRIPTION	UNIT COST	EXTENDED COST	GL Coding
1	1.00	Each	Procurement purchase per NRS 332: Replace Surface Ski Lift 2021/2022 Capital Improvement Project; Ski #3467LE1703; Vendor: Star Lifts USA	\$55,565.00	\$55,565.00	340-34-990-8120 Project # 3467LE1703

	TOTAL	\$ 55,565.00
--	--------------	---------------------

Comments:
USER ID

The District is granted Tax Exempt Status by the State of Nevada, State ID 88-7600004-K, therefore any goods or services delivered to the District within the boundaries of the State of NV are exempt from NV sales and use tax.

All shipments should be freight prepaid F.O.B. destination. Unauthorized shipments will be returned at the seller's expense Title and risk of loss on all items shipped shall pass to the buyer at the F. O. B. destination.

Payments of all invoices is net 30 unless expressly written and acknowledged in writing by the District's Director of Finance or Controller. IVGID's Federal Tax ID Number is 88-0099974.

I CERTIFY THAT THE ABOVE PURCHASE IS FOR AN EXPENDITURE AS DEFINED BY NRS 354.520 OR AN EXPENSE UNDER NRS 354.523 AND THAT THE PURCHASE ORDER HAS BEEN ENCUMBERED AS DEFINED BY NRS 354.516.

Indra Winquest General Manager