

2024

# Requirements for Construction of Water & Sewer



**Scan for document**



**PUBLIC WORKS**

IVGID COMPLIANCE DIVISION

Incline Village GID

1/1/2024

# **IVGID REQUIREMENTS FOR CONSTRUCTION OF WATER & SEWER**

## **TABLE OF CONTENTS**

Table of Contents.....	1
Need to Know Information .....	2
Article 1. GENERAL SPECIFICATIONS .....	10
Article 2. WATER SERVICE LINE SPECIFICATIONS .....	10
Article 3. WATER METER SPECIFICATIONS .....	13
Article 4. FIRE SYSTEM SPECIFICATIONS.....	14
Article 5. DISTRICT REGULATIONS FOR BOILER/MECHANICAL SYSTEMS.....	15
Article 6. DISTRICT REGULATIONS FOR IRRIGATION SYSTEMS.....	16
Article 7. REGULATIONS FOR PRIVATE BACKFLOW TESTING .....	16
Article 8. SEWER SERVICE SPECIFICATIONS.....	16
Article 9. INDIVIDUAL SEWER PUMP STATIONS.....	22
Article 10. COMMUNAL UTILITY SYSTEM SPECIFICATIONS .....	24
Article 11. JOINT TRENCHING SPECIFICATIONS.....	24
Article 12. IVGID APPROVED INSTALLATION DETAILS .....	24

# **IVGID REQUIREMENTS FOR CONSTRUCTION OF WATER & SEWER**

## **NEED TO KNOW INFORMATION**

### **IVGID Codes of Enforcement**

- The current approved edition of the Uniform Plumbing Code (UPC).
- Nevada Administrative Code (NAC water controls).
- Nevada Revised Statutes (NRS water controls).
- Ten State Standards.
- Incline Village General Improvement District Ordinances 1, 2, 4

### **Plan Checking Information that is needed but Often Missed**

- All Utility Easements.
- Fences and their locations identified on the plans.
- All locations of new private water and sewer utility lines and their details.
- Lawn irrigation system(s), complying with all IVGID 33% rules and regulations.

### **Agency Requiring Additional Permitting**

- **NDOT Permit:** Nevada Department of Transportation (NDOT) oversees state roadways and rights-of-way that may need approval for your project. The design consultant is responsible to prepare all documentation as required by the terms and conditions relating to the Right-Of-Way Occupancy Permit.
- NDOT Link:  
<https://www.dot.nv.gov/home/showpublisheddocument/17109/637085393360430000>
- The North Lake Tahoe Fire Protection District is located at 866 Oriole Way, in Incline Village, Nevada. The NLTFPD reviews/approves all fire sprinkler system designs and types. IVGID approves all water connection points to the potable water system supplying all fire systems.

**Water service line abandonment:** Contact the IVGID Pipeline Supervisor at 775-832-1289 and schedule a water service line freeze.

### **Construction Types**

- Interior/exterior remodel only with no additional water or sewer fixture units.
- Interior/exterior remodel with additional water and sewer fixture units identified on plans.
- All demo/new construction with additional water or sewer fixture units identified on plans.

### **Interior/exterior remodel only; no additional water or sewer fixture units.**

- When a project requires a Fire Sprinkler System:
  - Designer to indicate on plans that a fire sprinkler system is required and the size of water tap needed for the new fire sprinkler system. Review water details within this document.
- Cross-Connection Control Devices must be indicated on plans in a location such as a mechanical room or dedicated area approved by IVGID.
- Type of heating system.
- Lawn landscaping system.
- Location of the water pressure regulator.

## **IVGID REQUIREMENTS FOR CONSTRUCTION OF WATER & SEWER**

- Grade elevation for a sewer backwater valve.

### **Interior/Exterior Remodel with Additional Water and Sewer Fixture Units Identified on Plans**

- When a project requires a Fire Sprinkler System:
  - Designer to indicate on plans that a fire sprinkler system is required and the size of water tap needed for this fire sprinkler system. Review water details within this document.
- Cross-Connection Control Devices must be indicated on plans in a location such as a mechanical room or dedicated area approved by IVGID.
- Water line must be identified on the plans, and comply with all UPC requirements.
- Sewer line must be identified on the plans, and comply with all UPC requirements.
- Unless approved by an agent of the District, all water meters and their locations must be identified on the plans, and located at the parcel property corner of said parcel.
- All water and sewer utility easements are to be identified on the plans.
- All fences are to be identified on the plans.
- Type of heating system are to be identified on the plans.
- Lawn irrigation systems are to be identified on the plans.
- If this project requires a water meter upgrade, the parcel will require a property survey identifying all property corners and lines.
- Grade elevation for a sewer backwater valve.
- When a project requires a sewer lift pump station located outside of the footprint, refer to IVGID Sewer Detail - Pump Station documents within this document.

### **Demo/New Construction with Additional Water and Sewer Fixture Units Identified on Plans.**

- Parcel must have a survey identifying all property corners and lines.
- Complete a Washoe County Demo permit application.
  - If there is no existing structure, a demo permit is not needed.
- When a project requires a Fire Sprinkler System:
  - Designer to indicate on plans that a fire sprinkler system is required and the size of water tap needed for this fire sprinkler system. Review Water Details within this document.
- Cross-Connection Control Devices must be indicated on plans in a location such as a mechanical room or dedicated area approved by IVGID.
- Water line must be identified on the plans, and comply with all UPC requirements.
- Sewer line must be identified on the plans, and comply with all UPC requirements.
- Unless approved by an agent of the District, all water meters and their locations must be identified on the plans and located at the property corner of said parcel.
- All water and sewer utility easements are to be identified on the plans.
- All fences are to be identified on the plans.
- Type of heating system to be identified on the plans.
- Lawn irrigation systems to be identified on the plans.
- Grade elevation for a sewer backwater valve.
- When a project requires a sewer lift pump station located outside of the footprint, refer to IVGID Sewer Detail - Pump Station documents within this document.

# **IVGID REQUIREMENTS FOR CONSTRUCTION OF WATER & SEWER**

## **DEFINITIONS**

### **Agent or IVGID Inspector**

That person so designated by the District Engineer to perform inspections, tests, fixture unit counts, and related work in determining compliance with IVGID construction specifications, standards and Ordinances. Inspectors review construction plans, manage the District's cross-connection control and grease programs, and perform all field inspections related to water and sewer systems.

Pipeline Distribution/Collection Supervisor: Contact (775) 832-1289 for all water and sewer utility line locations and requests for freezing of existing water lines.

### **Air Gap**

An air gap is an unobstructed vertical space between the water outlet and the flood level of a plumbing fixture. This design allows water to flow from the drinking water supply, but there is no way for water to flow into the drinking water system.

An approved air gap shall be at least double the diameter of the supply pipe, measured vertically, above the overflow rim of the vessel, and in no case less than one inch. Any air gap placed near sidewalls, ribs or similar obstructions shall be a distance greater than three times the diameter of the effective opening.

Note: All new water services greater than 2 inches must maintain an approved air gap until all disinfection processes have been approved by the District inspector, and the contractor receives written approval allowing the contractor to make a physical water connection to the IVGID potable water system.

### **Backflow Prevention and Cross-Connection Control Program**

The District reserves the right to require the installation of an approved backflow prevention assembly.

1. No water service connection to any premises may be installed or maintained by the District unless an Air Gap, RPA, DC, PVB or SVB, as required by State laws and regulations and District Ordinance, protects the water supply. Service of water to any premises may be discontinued by the District if a backflow prevention assembly has been removed, bypassed, or if an unprotected cross-connection exists on the premises. Service will not be restored until such conditions or defects are corrected. The IVGID inspector shall determine what type of backflow device is approved for each Degree of Hazard present.
2. The customer's system shall be open for inspection at all reasonable times to authorized representatives of the District to determine whether cross-connections or other structural or sanitary hazards exist. When such a hazard becomes known, the Director of Public Works may deny or discontinue service to the premises by providing for a physical break (air gap) in the service line until the customer has corrected the condition(s) in conformance with state law and local Ordinances relating to plumbing and water supplies, and any regulations adopted pursuant thereto.

## **IVGID REQUIREMENTS FOR CONSTRUCTION OF WATER & SEWER**

**Codes:** Sewer and water service lines shall be constructed in accordance with the latest edition of:

- A. The current Uniform Plumbing Code (UPC) adopted by the Board of Trustees, as prepared by the International Association of Plumbing and Mechanical Officials, except for particular requirements in excess of the Codes, as stated herein.
- B. Nevada Administrative Code 445A - Water Operations
- C. IVGID Ordinances.

### **Conditional Final**

A Conditional Final may be given at the discretion of IVGID Inspectors. In this case, the Washoe County Building Department will sign off on the permit, and IVGID will hold the contractor/owner responsible for completing all IVGID requirements before completing work required by IVGID.

A written acknowledgement of requirements from contractor/owner may be required and must be approved by an IVGID Inspector.

### **Connection Fees, New Construction**

- A. All connection fees must be paid before the District will approve plans for construction, inspect service lines, or install water meters.
- B. Payment of connection fees constitutes acceptance of a new service connection application by the District.
- C. Connection fees shall be charged at the rate in effect on the day of application for a Building Permit from Washoe County.
- D. Any application that has been accepted by the District shall be considered vacated if the Applicant fails to commence construction and connection to the District's water system within 540 days of such acceptance.
- E. Connections not made within 540 days will be subject to connection fees in effect at the time of connection.
- F. Previously paid connection fees shall be credited to the new connection fee rate, or may be returned to the Applicant upon written request.
- G. No fees will be refunded after connection.

### **Connections**

All new water service and sewer connections shall comply with one of the following conditions, whichever is applicable.

- A. **Single Family Residence:** Where a single-family residence is constructed on a single parcel, direct connection to the public water and sewer system shall be made. Should the parcel not border upon a utility easement or dedicated right-of-way containing the public utilities, it is the property owner's responsibility to obtain the necessary easements and/or construct main extensions as determined to be necessary by the District. Reimbursement for main extensions is provided should additional

## **IVGID REQUIREMENTS FOR CONSTRUCTION OF WATER & SEWER**

connections be made to the extended main within a ten-year period, in accordance with the standard "District Main Extension Agreement."

- B. Multiple Residences with Common Land Ownership / Commercial Developments: A development with more than one residential building with common land ownership shall be served by communal water and sewer systems. The development shall be metered near the point where the service line crosses the property line, and each unit shall be served by an individual meter; however, the only meter read for billing purposes is the master meter. The District shall approve the number, location and size of meters.
- C. IVGID reserves the right to meter parcels as it sees fit for the benefit of the general public. The operation and maintenance of the system as well as payment of fire protection fees shall be the responsibility of the owners of the property served or of the HOA having legal responsibility for buildings and grounds.

### **Corrections Notice**

Written instructions to bring noncompliant work up to code requirements.

### **Cross-Connection**

- A. A cross-connection is an ACTUAL or POTENTIAL link between the potable water supply and a source of contamination (sewage, chemicals, gas, etc.). This link can be envisioned as a conduit or hose permitting the transfer of foreign material into a safe drinking water system.
- B. Any new installation of water piping greater than 2" is considered a lethal cross-connection and must be protected with an air gap until all approved disinfection processes have been completed and approved by IVGID. No physical connection to the IVGID potable water system will be allowed until written approval of all work has been received from the District's agent/inspector.

### **Customer Service Line**

The plumbing from point of connection in the street to the property. This is the responsibility of the property owner, including all maintenance and repairs.

### **Customer Service Valve (CSV)**

- A. It is recommended that property owners provide a CSV on the customer service line side of the meter and as close to the meter location as practicable, to control the flow of water to the premises.
- B. Neither the customer, nor their agent, shall access the meter to turn water on or off; a meter tampering fine will be assessed if this happens.

### **Degree of Hazard**

- A. The degree of hazard is a commonly used phrase utilized in cross connection programs and is simply a determination on whether the substance in the non-potable system is toxic (health hazard) or non-toxic (non-health hazard). There are three degrees of hazard: Severe, moderate and minor.

## **IVGID REQUIREMENTS FOR CONSTRUCTION OF WATER & SEWER**

1. **Severe Hazard:** Any conditions with the potential to introduce a biological or living organism into the water supply system and its operations, which could create a potentially fatal situation to the water consumer or water supply system.
2. **Moderate Hazard:** Any condition, device, or practice in the water supply system and its operation, which could create or may create a danger to the health and well-being of the water consumer.
3. **Minor Hazard:** A minor hazard is when potential backflow can pollute the drinking water. Pollution is defined as materials that can cause undesirable effects to the water, such as discoloration, bad smell or taste, but will not cause sickness or death.

### **District**

The Incline Village General Improvement District (IVGID).

### **District Engineer**

The Engineer appointed and acting for the District, who shall be a registered Civil Engineer in the State of Nevada.

### **Fire Sprinkler Systems**

IVGID does not review a project to determine the need for fire sprinklers. The applicant is advised to contact the North Lake Tahoe Fire Protection District (NLTFPD) at (775) 831-0351 to determine the applicable requirements for their project and the potential need of a fire sprinkler system.

The NLTFPD will make available their "Fire Prevention Bureau Standard Operation Procedure" upon request. Their formal review of the plans will occur in conjunction with the District review; however, District approval will not be granted prior to NLTFPD approval.

A fire sprinkler system may require a separate service line tapped to the District's water main, as determined by the NLTFPD. In some cases, a two-headed calculation may be allowed, eliminating the need for a new tap and street cuts.

If used in conjunction with fire sprinkler service, the potable water service line must be approved by the District and located at the property line by means of a separate valve and riser pipe with a properly boxed enclosure.

All Fire lines shall be metered.

### **House Piping**

All piping and fittings installed within a home or building, past the customer service line, is the responsibility of the property owner, including all maintenance and repairs.

### **Inspection Fees**

Inspection fees shall be invoiced at the rates shown in Exhibit C, and are subject to change from time to time at the discretion of the Director of Public Works.

### **Inspection Scheduling:**



## **IVGID REQUIREMENTS FOR CONSTRUCTION OF WATER & SEWER**

No backfilling shall be performed until the District has inspected and approved the work. The contractor shall schedule all inspections at least forty-eight (48) hours in advance. All testing shall be performed in the presence of an authorized representative of the District. Inspection fees shall be set by the District and charged for each inspection.

A fee may be charged at a rate set by the District for re-inspection if the site is not ready for inspection, or if the initial inspection fails.

If not ready for scheduled inspection, please call 775-832-1224 for cancellation.

### **Inspector**

See "Agent or IVGID Inspector," above.

### **Ordinances**

IVGID Ordinance 2 - Sewer and Ordinance 4 – Water are made a part of this document by reference herein, and can be found at <https://www.yourtahoeplace.com/ivgid/resources/ivgid-ordinances>.

### **Parcel Owner**

The owner of a parcel within Incline Village/Crystal Bay. The parcel owner is responsible for all costs incurred for work on such parcel, including but not limited to plan check fees, permit fees, construction costs, utility connection fees, NDOT and Washoe County street cut fees, utility easements, and all water and sewer utility appurtenances which are required in order to comply with Nevada State Health Codes and IVGID Ordinances.

### **Permits**

- A. IVGID does not issue permits.
- B. It is the parcel owner's responsibility to acquire all required permits prior to the installation of any water or sewer systems, pursuant to Nevada State regulations and District Ordinances.
- C. NDOT: The Nevada Department of Transportation (NDOT) oversees state roads and rights-of-way. With the exception of Ski Way, road maintenance within the District is not an IVGID function. The design consultant will be required to work with NDOT for any project that requires a Right-Of-Way Occupancy or Street Cut Permit.  
<https://www.dot.nv.gov/home/showpublisheddocument/17109/637085393360430000>
- D. TRPA: <https://www.trpa.gov/permitting-process/>
- E. Washoe County Building Department: Prior to building permit issuance, the Washoe County Building Department will require proof that IVGID has examined the plans for compliance with all water, sewer and trash related projects within the District.  
[https://www.washoecounty.gov/building/getting\\_started/what\\_requires\\_a\\_permit.php](https://www.washoecounty.gov/building/getting_started/what_requires_a_permit.php)

### **Plan Checking Process**

The District works in cooperation with the Washoe County Building Department, and uses their Permit Process and Permit #, for project reviews. The District will review information provided to the Building

## **IVGID REQUIREMENTS FOR CONSTRUCTION OF WATER & SEWER**

Department relating to water and sewer systems, including utility easements, existing or new fire sprinkler systems, water and sewer lines, backflow devices, pressure regulators, proposed fences, lawn irrigation systems, etc.

### **Plan Check Fees**

- A. In accordance with the District's most recently adopted revision of the Uniform Plumbing Code, a plan check fee shall be required for all plans requiring the District's review and approval.
- B. Plan checking is performed for any aspect of a project specific to water and sewer systems, and only one plan check fee is assessed per project plan set.
  - 1. Any plan revision requiring rechecking shall necessitate the charge of an additional plan check fee.
- C. Plan check fees are invoiced at the rates shown in the current published District Ordinances.

### **Private Communal Water System**

Any system served by District water/sewer within a communal water system, where maintenance and repairs of these systems are the responsibility of the HOA. All private communal water systems must comply with IVGID water and sewer ordinances.

### **Uniform Plumbing Code/International Association of Plumbing & Mechanical Officials**

- A. The Uniform Plumbing Code (UPC) and International Association of Plumbing & Mechanical Officials (IAPMO) provisions are made a part of this document by reference herein.
- B. Where inconsistencies exist, IVGID Ordinances will take precedence over UPC or IAPMO requirements or definitions.

### **Violations**

Any property found to be in violation of any provision of this document or District Ordinance, rule or regulation, shall receive written notice by an authorized District representative stating the nature of the violation and providing ten (10) business days for the satisfactory correction thereof. The property owner or their agent or tenant shall, within the period of time stated, permanently cease all violations and shall immediately work to correct the violation.

The property owner shall be held strictly responsible for all acts of their agents, tenants or employees under the provisions of this or any District Ordinance, rule or regulation of the District.

- A. Violations of these Regulations may be subject to civil monetary penalties as established by:
  - 1. Nevada Revised Statutes (NRS) or Nevada Administrative Code (NAC);
  - 2. Nevada Division of Environmental Protection (NDEP), and
  - 3. Any penalties as may be adopted by the District Board of Trustees.
- B. Continuing Violations. For purposes of the computation of penalties, each day of a continuing violation beyond the 10-business-day time limit stated above shall be deemed a separate violation.

## **IVGID REQUIREMENTS FOR CONSTRUCTION OF WATER & SEWER**

### **Water Rights**

- A. In addition to compliance with all other standards for granting applications for new connections and as a condition of project approval, applicants shall be required to assign water rights to the District in an amount sufficient to support the proposed development.
- B. Upon project approval, the District will provide issuance of a will-serve letter, sign-off on condo plat, approval of plans, as applicable.
- C. Water rights assigned to IVGID as a condition of project approval will not revert back to the applicant.
- D. All assignments of water rights to IVGID shall be completed and approved by the State Engineers Office.

### **Article 1. GENERAL SPECIFICATIONS**

- 1.01** IVGID shall provide to parcel owner or his agent an approximate location and size of all District utility lines. It is the property owner or their agent's responsibility to field locate and confirm utility locations and sizes before digging or cutting any streets. Refer to "Permits," above.
- 1.02** These requirements are applicable within the jurisdiction of the Incline Village General Improvement District for the building of water and sewer service lines from the property or easement line to the house or building and within existing rights-of-way (ROW). Service lines on private property shall be constructed and maintained by the property owner in accordance with these requirements.
- 1.03** Water and sewer taps require scheduling for inspections at least 48 hours in advance. Line locations must be confirmed prior to any excavations.
- 1.04** **Abandonment of Connection Points:** All existing water and or sewer connection points must be completed to all IVGID specifications by means of Full Circle Repair Clamps or other means approved by the District agent/inspector.
- 1.05** **Water service line abandonment:** Contact the IVGID Pipeline Supervisor at 775-832-1289 to schedule a water service line freeze.

### **ARTICLE 2. WATER SERVICE LINE SPECIFICATIONS**

- 2.01** **Service Line Requirements for Two Inch (2") and Smaller:**
  - A. For each service line upgrade required per the UPC, each lot shall be serviced by a separate service connection of required size from the District main water line to the water meter.
  - B. Fire service and domestic water service shall use the same main line water tap, with separation downstream of the water meter. The Fire line shall continue through an iron body gate valve with a two inch (2") operating nut with an epoxy-coated body, terminating at structure.

## **IVGID REQUIREMENTS FOR CONSTRUCTION OF WATER & SEWER**

- C. The domestic water line shall be connected off a tee fitting downstream of water meter and upstream of fire gate valve. The domestic line shall continue through an iron body gate valve with a two inch (2") operating nut with an epoxy-coated body and then through a curb stop, terminating at structure. See Combined Domestic and Fire Water Service Detail.
- D. The District requires that all approved piping must be installed through the foundation and capped for pressure testing. Domestic water and Fire water piping must be cored through the foundation utilizing link seals. Speak to an IVGID inspector for installation criteria or call 775-832-1224 if installed under the foundation. SDR 35 and/or Ductile Iron piping must be used as a sleeve.
- E. IVGID will make inspections up to and through the foundation on all water and fire services.
- F. 4" and larger applications, see Water Services for Metered Domestic and the Detector Check Fire Water Services Detail. 4" stainless steel risers shall be installed on all 4" and above lines. Risers entering through the foundation of the building need to be cored and link sealed. Other means of installation can be approved by the District agent/inspector.

**2.02 Pipe Materials:** Water service lines shall conform to the UPC and applicable AWWA standards and be Type K copper tubing or 200-250 PSI PE 4710 tubing, SDR-9 ASTM D-2737, SDR-11 D-3035 copper tube size. PVC C-900 DR14 Class 305 and Ductile Iron Pipe class 305 are allowable for services four inches (4") or larger. If copper is used, service lines two inches (2") in diameter or smaller shall be Type K copper conforming to ASTM B-88. Customer service valve boxes must be Christy G-5 or equivalent concrete box with a steel lid marked "Water." Line sizes are to be commensurate with health standards to ensure that no stagnant water will accumulate. All service line fittings shall be mechanical compression type, or soldered with lead-free UPC approved solder. Solder spools shall be available for inspection.

From the District's main line to the meter, only mechanical joints will be allowed. Under no circumstances will pipe crimping or soldering be accepted by the District.

**2.03 Curb Stops:** Shall be non-stop and waste type and be approved by UL Listed and FM Approved. Lead free curb stops shall be installed no more than two feet (2') downstream of the water meter box/pit with an approved G-5 round concrete box with a steel lid marked water.

**2.04 Air Relief Valve:** Air relief valve shall be single-housing style, cast-iron body, stainless steel trim, one inch (1") inlet and outlet connections, and/or 5/16" diameter orifice, for a working maximum pressure of 300 psi. Contact the District at 775-832-1224 for Model and Installation Criteria.

**2.05 Trenching:** All trenching for water and sewer lines must meet OSHA requirements.

**Separation:** All water lines shall be placed at and maintain a minimum depth of thirty-six inches (36") and be on an undisturbed shelf. All water utility lines, domestic and fire sprinkler systems must keep a twelve inch (12") separation at all times. All sewer service lines shall maintain at least twelve inches (12") vertical separation below the water line, and maintain a minimum horizontal separation of twelve inches (12") from water line at all times. If the sewer line is pressurized, the vertical separation is twelve inches (12") below the water line and the horizontal separation is five feet (5'), in a separate trench. Any other installation must be approved by IVGID Compliance. THIS IS AN IVGID REQUIREMENT.

## **IVGID REQUIREMENTS FOR CONSTRUCTION OF WATER & SEWER**

- 2.06 Tracer Wire:** All pipe materials (except copper) require an approved #10 tracer wire, attached to the pipe every five feet (5') by means of tape, and made accessible at the meter yoke.
- 2.07 Caution Tape:** Warning Tape shall be blue in color, three inches (3") in width, 5 mil in thickness, permanently printed "CAUTION: BURIED WATER LINE BELOW," installed twelve inches (12") above the pipe.
- 2.08 Bedding:** Material used for the pipe zone shall be sand, cinder, or Class A backfill with no mineral material larger than three eighths of an inch (3/8"), as stated in Section 200, Aggregate, of the Standard Specifications for Public Works Construction for Washoe County. The trench bottom shall be level and smooth, and excavated as needed to maintain a minimum of six inches (6") of bedding below the grade required by the underside of the pipe barrel, with twelve inches (12") above the pipe. Minimum allowable cover for water service lines is thirty-six inches (36").
- 2.09 Backfill:** All backfill shall meet the requirements of Class E backfill as stated in Section 200, Aggregate, of the Standard Specifications for Public Works Construction for Washoe County, with no rock larger than four inches (4"). If native material does not meet these requirements, backfill material shall be imported. Minimum allowable cover for water service lines is thirty-six inches (36").
- 2.10 Main Line Tapping:** When making a new service connection to the District main line, all taps shall maintain a minimum of two feet (2') separation between all fittings, joints and appurtenances. This applies to all main line pipe. Any other installation must be approved by the District.
- 2.11 Tapping Saddles and Tapping Sleeves:**
- Tapping Saddles: For water services shall be epoxy coated ductile iron body with two stainless steel straps. Saddles shall be suitable for 250-psi service and torqued to manufacturers specifications.
- Tapping Sleeves: Shall be Stainless Steel and shall be or equivalent for all taps larger than two inches (2") in size. Shall be torqued to all manufacturers specifications by means of a torque wrench.
- All Tapping Sleeves: Shall be hydrostatically tested. The hydrostatic test pressure (NO air testing permitted) shall not exceed 1.25 psi times the pressure inside of the pipe being tapped at the time of the test. The testing time shall last for 15 minutes with no loss. Air testing of any tapping SLEEVE is prohibited. Torque all bolts to manufacturer's specifications.
- 2.12 Cathodic Protection:** This is not required on any District-approved plastic piping. Installation of cathodic protection is required for all copper water services. A 5-pound "high potential" magnesium anode, packaged in chemical backfill with ten feet (10') of #12 lead wire, shall be used. The anode shall be buried at a minimum depth of forty-eight inches (48"). A bronze or brass clamp shall be used to attach the lead wire to the meter yoke. The anode must be a minimum of thirty-six inches (36") from the meter yoke, service line or water main. If a locating wire is installed on the water service line, cathodic protection shall be installed a minimum of once every five hundred feet (500') and at each intersection along that line.
- 2.13 Pressure Regulator and Isolation Valve:** At all service locations, property owners are required to furnish individual lead free pressure regulators. All pressure regulators must be installed under the house within ten feet (10') of access door, readily accessible, and approved by the District. If house is slab-built, the pressure regulator must be located in a readily accessible and District-approved

## IVGID REQUIREMENTS FOR CONSTRUCTION OF WATER & SEWER

location. An isolation valve is required directly upstream of the pressure regulator for service of the regulator and isolation of the structure's plumbing.

- 2.14 Water Pressure Testing:** The Contractor shall provide all labor, tools, and equipment necessary to perform required tests. Any faulty equipment shall be replaced before any test is accepted. Water lines four inches (4") and greater shall be tested/disinfected per the following: (Length x Pipe Diameter x Square root of pressure divided by 148,000.) All water lines smaller than four inches (4") will be tested at the District's main line pressure.
- 2.15 Water Pressure Testing time:** Minimum time frame of 1 hour of IVGID engineering may require a longer testing time, based on scope of work.

$$\text{Example: } L = \frac{SD (\text{square root of pressure})}{148,000} \text{ (1000 lineal feet of 6" pipe tested at 200psi)}$$

$$\text{Example} = \frac{1000' \times 6" \times 13.41}{148,000} = 80,460 = .54 \text{ gallons}$$

$$32\text{oz.} = 1 \text{ qt.} \quad 64 \text{ oz.} = 2\text{qt.} \quad 96 \text{ oz.} = 3\text{qt.} \quad 128\text{oz.} = 4\text{qt./1 gallon}$$

**Chlorine Test:**  $\geq 50\text{ppm}/24\text{hr}$   $\geq 10\text{ppm}/\text{Flushing/residual}/\text{BACT-T- Testing}$ .

2nd Option Test:  $\geq 200\text{ppm}/3\text{hrs}$   $\geq 200\text{ppm}/\text{Flushing/residual}/\text{BACT-T-Testing}$ .

Note: All BACT-T-Testing is a 24 Hr. testing timeline. (Monday – Wednesday)

**During water pressure testing and disinfection, all new water piping must maintain an approved air gap from the IVGID potable water system. No physical water connection point(s) can be installed until all Back-T testing has been approved by the District.**

**Service Line Test:** After the meter is set, the water will be turned on and the line tested for leaks and proper installation. The service line shall be exposed at this time and all visible leaks shall be repaired. Once approved, the water service line may then be backfilled.

- 2.16 As-Built Plans:** Contractor is responsible to submit As-Built plans to the District upon completion of work. These utility plans/drawing must have 2 reference points taken from each end of building(s) for all water meter and shut-off valves. For projects larger than a duplex, the District will require plans or drawing to be provided as a PDF file. Plans and drawings will be approved by the District agent or inspector on a case-by-case basis.

### **Article 3. WATER METER SPECIFICATIONS**

- 3.01 Meters:** All water meters are provided by IVGID. Contractor must survey said parcel property corner and install water meter and stake at the approved property corner. Any other location of the water meter must be approved by District agent or inspector.
- 3.02 Temporary Meter Sets:** A temporary meter may be set upon request. A temporary meter rental form must be completed and approved by a District agent or inspector.
- 3.03 Meter Setters:** Meter setters are required and, for ¾" and 1-inch services, shall be the Mueller Easy Setter Meter Pit with no bypass; 1.5" and 2" services shall use the Mueller EZ Vault Meter Setter with no bypass. No coils will be permitted.

## **IVGID REQUIREMENTS FOR CONSTRUCTION OF WATER & SEWER**

- 3.04 Meter Pits:** Meter pits for ¾" and 1" services shall be the Mueller EZ Setter Meter pit with no bypass; 1.5" and 2" services shall use the Mueller EZ Vault Meter Setter with no bypass. NO COILED PITS ARE PERMITTED. The meter lid shall be a DFW18MUE-1MQF, shall have a modified lid hook, be non-locking and be marked "Water." Meter vaults for larger than two-inch (2") services must be approved by IVGID, accommodate all appurtenances, and provide a 12" clearance on all sides within the box. The lid must be a steel spring-loaded bolt-down type. Meter installations shall be made at the property line, in the right-of-way (ROW). Meter locations to be marked with a blue stake.
- 3.05 Concrete Boxes:** G-5 Traffic Rated Boxes, F-8 Non Traffic Rated Boxes B-12, 16, 36, and must be approved a District agent or inspector.

### **ARTICLE 4. FIRE SYSTEM SPECIFICATIONS**

- 4.01 Fire Service Requirements:** The North Lake Tahoe Fire Protection District will determine the size of connection required for fire service and adequacy of system for fire protection. Fire service taps will be made using the same materials and methods as stated herein for service taps. The District requires that the beginning point of the fire system shall be on the downstream side of the backflow prevention device. All backflow devices must be approved by the District and all discharge lines must be installed by the contractor and approved by the District.
- A. **Service Line Requirements, 2" and Smaller:** For each service line upgrade required per the UPC, each lot shall be serviced by a separate service connection of required size from the District main water line to the water meter. Fire service and domestic water service shall use the same main line water tap with separation downstream of the water meter. The fire line shall continue through an iron body gate valve with a two inch (2") operating nut with an epoxy coated body and terminate at structure. The domestic water line shall be connected off a tee fitting downstream of water meter and upstream of fire gate valve. The domestic line shall continue through an iron body gate valve with a two inch (2") operating nut with an epoxy coated body and then through a curb stop and terminate at structure. Please see diagram Combined Domestic and Fire Water Service detail or contact the IVGID Utilities Department at 775-832-1224 for more information. The District requires that all approved piping must be installed to within five feet (5') of foundation and capped for pressure testing.
- B. **Fire Service Line Requirements, 4" and Larger:** All fire systems requiring a 4" or larger pipe size must install a single-check detector, IVGID approved 250 PSI piping and one-piece stainless steel riser with anchorage (see Detail Page 26). All 4" or larger fire systems must be chlorinated/disinfected to IVGID specifications and/or Nevada state codes and regulations. All chlorination/disinfection must be witnessed and lab tested by IVGID **before any physical water connection point(s) can be made to the IVGID potable water system.**
- 4.02 Automatic Sprinkler System Design Criteria Design:** The criteria for automatic systems can be found in the most current adopted editions of the National Fire Protection Association (NFPA) Standard 13 and NFPA Standard 13R with amendments (13D is not acceptable). A minimum 10-psi margin between the available water supply and the system demand point, including any required inside hose stream

## **IVGID REQUIREMENTS FOR CONSTRUCTION OF WATER & SEWER**

allowance, is required by NAC 477.465. (Customary margin allowance of only ten percent (10%) common in other regions is not allowed by this Nevada Fire Marshal regulation).

### **Notes**

- All single-family dwellings larger than 10,000 square feet or more than four (4) stories in height must conform to the design requirements in NFPA 13 (IFC 903.3.1.1).
- A “modified” 13R System may be considered for remodel projects less than 10,000 square feet (modified 13R systems can be requested and will be reviewed on a case-by-case basis by the NLFPSD Fire Prevention.
- Designers of the fire sprinkler systems must hold a minimum Level II certification from the National Institute for Certification in Engineering Technologies (NICET) be licensed as a professional engineer pursuant to Chapter 625 of NRS.

**4.03 Separation:** All fire sprinkler systems must be separated from the District water system with an approved backflow prevention device. This device must be approved by the District and in compliance with all State and Local codes.

- A. Double Check backflow prevention devices shall be approved for class one (1), two (2), three (3) or four (4) fire systems when chemical additives are not being used. When a Double Check backflow prevention device has approval from the District to be installed on class one (1), two (2), three (3), or four (4) fire systems the installation must meet all State and local codes. The District also requires a sign to be placed in an approved location, with two inch (2”) red letters on a white background stating the class of system, water only, absolutely no additives of any kind.
- B. Reduced pressure backflow prevention devices shall be approved for class four (4), five (5) or six (6) fire systems when chemical additives are being used. The installation must meet all State and local codes.

### **ARTICLE 5. DISTRICT REGULATIONS FOR BOILER/MECHANICAL SYSTEMS**

**5.01 Boiler Backflow:** All boiler/mechanical systems must be separated from the District water system with an approved reduced pressure backflow prevention device or an approved air gap. It must be installed in compliance with all State and local codes, and must be plumbed from a domestic cold water supply only. All backflow reduced pressure assembly backflow devices, discharge lines must be installed by the contractor and approved by the district. Boilers with a self contained unit inspected and approved by IVGID do not need an approved backflow device.

**5.02 Heat Exchangers:** All heat exchangers used for domestic hot water service must be double walled.

**5.03 Hot Water Tanks:** All boilers that heat a hot water tank must be equipped with a double walled heat exchanger.



## **IVGID REQUIREMENTS FOR CONSTRUCTION OF WATER & SEWER**

### **ARTICLE 6. DISTRICT REGULATIONS FOR IRRIGATION SYSTEMS**

- 6.01 Irrigation Requirements:** All irrigation systems require a Washoe County Irrigation permit for construction. All work must comply with the District landscape packet.
- 6.02 Separation:** All irrigation/sprinkler systems must be separated from the District water system with an approved backflow prevention device installed to all State and local codes.
- 6.03 Irrigation Materials:** Materials shall comply with the District specifications as type K copper or brass. All fittings must be approved curb stops, Drain Valves and unions for winter time removal. Devices shall be plumbed so no water shall be in standpipes when device is removed for winter time.
- 6.04 Inspections:** All inspections of connections to the domestic water line is required, please call IVGID Compliance at 775-832-1224 to schedule an appointment. On-site inspection prior to installation is highly recommended, to assure compliance with District regulations.

### **ARTICLE 7. REGULATIONS FOR PRIVATE BACKFLOW TESTING**

- 7.01 Forms:** All IVGID backflow-testing forms must be properly filled out. All testing forms must be submitted to the District within two (2) working days from the date of the test. Compliance@IVGID.org
- 7.02 Testers:** All testers must be licensed with the American Water Works Association (AWWA).
- 7.03 Device Certification:** Any backflow device that does not pass the initial certification test must be repaired and retested. If repairs require delay due to parts, etc., the District will allow five (5) additional working days for such repairs and retest. If a repair & retest require longer than the five (5) working days, an additional extension must be approved by the District.
- 7.04 Compliance:** Failure to comply with 7.01 or 7.02 will result in the tester's name being given to the Northern Nevada Backflow Administrator for AWWA.
- 7.05 License/Calibration:** Proof of current AWWA license and approved annual gauge calibration must be submitted to the District with every test or group of tests. These may be emailed to compliance@ivgid.org hand delivered or mailed.

### **ARTICLE 8. SEWER SERVICE SPECIFICATIONS**

- 8.01 Materials:** Acceptable pipe materials are DUCTILE IRON or POLYVINYL CHLORIDE PIPE SDR 35, all of which shall conform to the specifications set forth in the UPC. Joints shall be of the same material as the pipe using internal rubber or plastic gaskets, or an external rubber sleeve using stainless steel bands, all as manufactured strictly for use with particular type of pipe. Solvent weld joints, ABS Piping, Brass or Copper shall not be permitted. Where different pipe materials are jointed the connection shall be made by the use of an approved mechanical coupling specifically manufactured for use with the different pipes to be joined. Fittings such as Max adaptor couplings or coupling approved by the district agents shall be approved. POLYVINYL CHLORIDE PIPE shall not be used where the cover is less than thirty-six inches (36") or greater than eighty-six inches (86"). DUCTILE IRON may be used when

## **IVGID REQUIREMENTS FOR CONSTRUCTION OF WATER & SEWER**

eighteen inches (18") of cover is available. For shallower depths, concrete encasement or other special means approved by the District must be used to protect the pipe.

- 8.02 Size:** Building sewer shall be a minimum diameter of four inches (4") or six inches (6") for single family residences. Building sewers for apartments, motels, and commercial establishments shall be sized in accordance with the requirements of the UPC and shall be four-inch (4") minimum size.
- 8.03 Trenching:** All trenching for water and sewer lines must meet OSHA Requirements.
- 8.04 Separation:** All water lines shall be placed at and maintain a minimum depth of thirty six inches (36") and be on an undisturbed shelf. All sewer service lines shall maintain at least 12 inches (12") vertical separation below the water line, and maintain a minimum horizontal separation of twelve inches (12") from water line at all times. If the sewer line is pressurized than the vertical, separation is twelve inches (12") below the water line and the horizontal separation is five feet (5') in a separate trench. Any other installation must be approved by IVGID Compliance. **THIS IS AN IVGID REQUIREMENT.**
- 8.05 Building Sewer Construction:** Where building sewer main line connections have not been provided by the District to the property, and/or the properties were not assessed for the building sewer installation, the property Owner shall assume the cost of providing the required connection. Owner shall be responsible for obtaining the necessary Washoe County street-cut permits and coordination with other utility agencies for their utility locations. Owner requesting the tap will be responsible for cutting pavement and excavating the trench to proper depth and grade. Owner shall be responsible for the tap to the main. Owner is responsible for laying building sewer with all required appurtenances.
- 8.06 Connection to the existing Sewer Main:** Shall be with an approved Romac style "CB" or equivalent double stainless steel strap saddle for transite, plastic, cast iron, or concrete mains. A Fernco Flexible tapping saddle with Part A and B epoxy may be approved. For vitreous clay main, a section must be removed and a wye installed with Romac style couplers or other approved by IVGID. The pipe grade for four inch (4") must be two percent (2%) grade or a minimum of 1/4" per foot of fall or greater. Six inch (6") diameter pipe must be one percent (1%) grade or a minimum of 1/8" per foot of fall or greater. The District requires that all approved piping must be installed within five feet (5') of foundation and capped for pressure testing.
- 8.07 Tracer Wire:** All pipe materials, except copper, require an approved #10 tracer wire attached to the pipe every five feet (5') by means of tape or other approved means, made accessible at the clean-outs.
- 8.08 Caution Tape:** Warning Tape shall be green in color, three inches (3") in width, 5 mil in thickness, permanently printed "CAUTION: BURIED SEWER LINE BELOW," and installed twelve inches (12") above the pipe.
- 8.09 Water/Air Testing:** Contractor shall provide all labor, tools, and equipment necessary to perform the required tests. Any faulty equipment shall be replaced before any test is accepted. Contractor shall supply a pressure gauge that can be read in increments of between one and five psi, in accordance with the UPC. Installation must pass the standard five pounds per square inch (5 psi) for fifteen (15) minute pressure tests, per the UPC. Mandrel/Ball/Flush testing will be required on all new sewer

## **IVGID REQUIREMENTS FOR CONSTRUCTION OF WATER & SEWER**

pipng. Mandrels shall be specifically designed for the piping being tested. This testing is typical of 4" and larger piping.

**Manholes** shall be tested with the ring, cover and grade adjustment rings installed. All pipes entering the manhole shall be plugged and braced and a vacuum of ten inches (10") of mercury shall be drawn. The vacuum pump shall be turned off and the time monitored as the vacuum drops one inch (1"). The vacuum must not drop more than one inch (1") for the duration of the time indicated in the following table:

<b>Diameter</b>	<b>Time</b>	<b>Mercury Level</b>	<b>Allowable Loss</b>
48 Inches	1 Minute	10 Inches	1 Inch max.
60 Inches	1 Min. 15 Sec.	10 Inches	1 Inch max.
72 Inches	1 Min. 30 Sec.	10 Inches	1 Inch max.

Manholes which fail the vacuum test shall have the defects located and repaired and the test shall be repeated. Repair and repeat testing shall be continued until the testing requirements are met.

- 8.10 As-Built Plans:** Contractor is responsible to submit As-Built plans to the District upon completion of work. These plans must be on a PDF file for any project larger than a Triplex. Smaller projects may be submitted on an 8.5" X 11" sheet of paper. These will be reviewed and approved by the District.
- 8.11 Bedding:** Material used for the pipe zone shall be sand, cinder, or Class A backfill with no mineral material larger than three eighths of an inch (3/8") as stated in Section 200, aggregate, of the Standard Specifications for Public Works Construction for Washoe County. The bottom of trench shall be level and smooth, and excavated as needed to maintain a minimum of six inches (6") of bedding below the grade required by the underside of the pipe barrel, with twelve inches (12") above the pipe. Minimum allowable cover for sewer service lines is twelve inches (12").
- 8.12 Backfill:** All backfill shall meet the requirements of Class E backfill as stated in Section 200, Aggregate, of the Standard Specifications for Public Works Construction for Washoe County, with no rock larger than four inches (4"). If native material does not meet the requirements then backfill material shall be imported. Minimum allowable cover for sewer service lines is twelve inches (12").
- 8.13 Clean-Outs:** A clean out shall be provided by the Owner within five feet (5') outside of the foundation. A clean out must also be installed where the building sewer crosses the property or easement line. All clean-outs shall be installed at intervals not to exceed one hundred feet (100'); variances in this length must be approved by IVGID Compliance. In a change of direction ninety degrees (90°) or more, a clean-out must be installed within one foot (1') of that transition. All clean-outs shall be cut to grade, plugged, and have a concrete box with metal lid marked "Sewer." Plugs shall be two piece expansion types similar to ETCO, T-cone stopper or equivalent steel or alloy is prohibited. Owner shall be responsible for keeping clean-out boxes from being buried or damaged.
- 8.14 Backwater Valves:** Installation of a backwater valve on lots with fixtures lower than the next upstream manhole, as more specifically explained in the UPC, shall be enforced. Backwater valves must be installed in an accessible location inside or outside of the structure. Outside installations will be required to be properly boxed, upstream of foundation cleanout. Please see the following Backwater Valve Diagram for a further explanation. Combination Backwater/Cleanouts may also be utilized call The IVGID Compliance Dept. 775-832-1224 for further details and installation criteria.

## **IVGID REQUIREMENTS FOR CONSTRUCTION OF WATER & SEWER**

- 8.15** **Max Adaptor Coupling:** Max adaptor the universal shielded sewage coupling for non-pressure sewer coupling for 4" 6" 8" 10" the 10" coupling with cover the 12" SDR range sewer piping.
- 8.16** **Link Seals:** Shall be used on all penetrations of Vaults and Foundations.

## IVGID REQUIREMENTS FOR CONSTRUCTION OF WATER & SEWER

### BACKWATER VALVE DIAGRAM

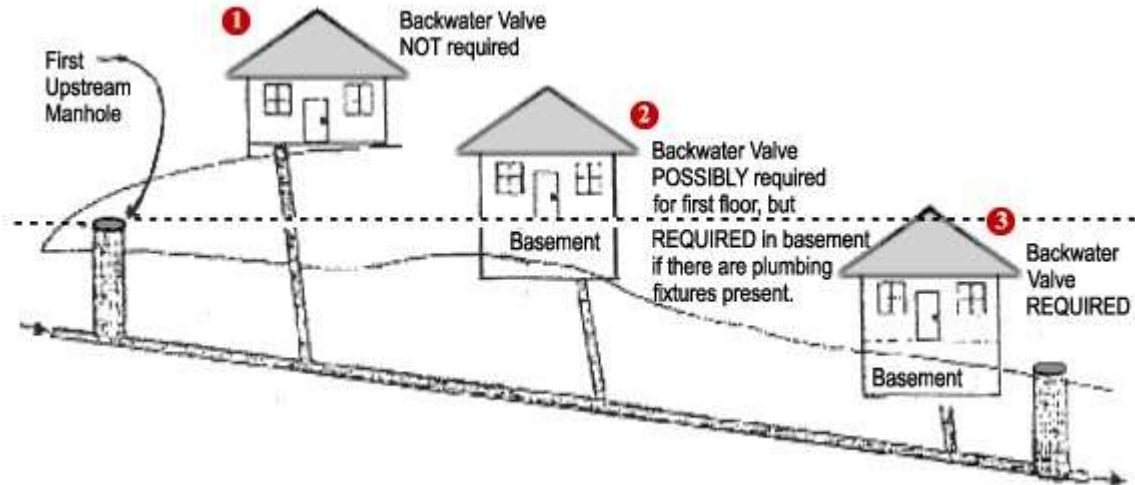

One of the keys to preventing a sewer backup in your basement is knowing your location in relation to the sanitary sewer system that serves your building or home. A sewer backup valve (backwater valve) can make all the difference between having your basement or home flooded knee deep with raw sewage and staying high and dry.

- **Home #1** does not need a backwater valve because water would drain from the first upstream sanitary sewer manhole which is lower than the inlet to the drain pipe in this home's basement. This home should not experience a flooded basement due to a sewer backup.
- Drains located on the first floor of **Home #2** might be safe as it is slightly higher (must be at least 24" higher) than the first upstream sanitary sewer manhole cover, but there are some cases in which pressure builds enough to temporarily allow water to flow at a level above the lowest drain. When in doubt, and especially when the second floor living space is installed, it is wise to install a backwater valve. However, any drain fixture in the basement of Home #2 would be below the level of the first upstream manhole and sewage backups could occur without a backwater valve.
- Any drain opening in **Home #3** would be located below the level of the first upstream sewer manhole cover so this home would definitely require the installation of a backwater valve.

All Backwater Valves shall be placed within the crawl space or confines of the home and be made readily accessible for maintenance and repairs. Exceptions can be made if the home is slab built.

Please contact IVGID Compliance 775-832-1224 for more details.

## **IVGID REQUIREMENTS FOR CONSTRUCTION OF WATER & SEWER**

### **8.17 Grease Interceptor, Interceptor and Separator Installation Requirements and Test Procedure:**

- A. Grease interceptors, interceptors and separators shall be required when and where necessary for the removal of grease, oil, sand, garbage, flammable wastes or other waste components not typically present in wastewater. No such device shall be required for residential service. Grease interceptors, interceptors and separators and sampling pits shall be constructed to prevent any bypass of matter prohibited in the wastewater system.
- (1) **Grease Interceptors.** Grease interceptors shall be installed for establishments where food is prepared or other establishments where grease is introduced into the drainage or sewage system in quantities that can effect sewer mains, effect wastewater treatment or have other negative impacts on the sewer system.
- Grease interceptor Plan Requirements: Plans submitted to the Washoe County Building Department for permitting grease interceptors shall include the following:
    - a) The design, operation and sizing of all interceptors shall be performed by a licensed engineer using the formula from the most recent District-adopted UPC, as specified in Appendix H, Section H 901.0.
    - b) No food waste disposal unit or dishwasher shall be connected to or discharge into any interceptor unless specifically designed for this function.
    - c) Make, model, and size of unit to be constructed.
    - d) Location of unit to be constructed. Interceptor shall be located as close to the source as possible and be accessible for servicing and sampling.
    - e) A sampling box shall be installed downstream of all grease interceptors.
    - f) A sewage backwater valve shall be installed immediately downstream of the sample box prior to connection with the building sanitary sewer.
    - g) Hydromechanical grease interceptors are not permitted.
    - h) Toilets, urinals and other similar fixtures shall not drain through an interceptor.
- (2) **Interceptors (Clarifiers) and Separators.** Interceptors and clarifiers shall be required for the proper handling of liquid wastes containing flammable wastes, sand, solids, oil, acid substances or alkaline substances or other ingredients harmful to the building. The design of these interceptors and separators shall be performed by a licensed engineer using the formula from the most recent District-adopted UPC, as specified in Appendix H, Section H 901.0. These types of interceptors are typically installed for auto repair facilities, car washes, warehouses and other similar facilities. For food establishments, see Grease Interceptor section, above.

## **IVGID REQUIREMENTS FOR CONSTRUCTION OF WATER & SEWER**

B. **Setting and Installation:** The grease interceptor, interceptor and/or separator shall be constructed following the Manufacturer's installation procedures, including accessibility, setting unit on level base, installing inlet and outlet pipes, inlet vented flow control(s), vents, grouting, sealing, setting and adjusting of grade rings, risers, frames, covers and all other hardware and appurtenances and sampling structures.

**8.18 Water Testing Policy and Procedure:** The Trap/Interceptor/Separator shall be tested to insure that the system as a whole is watertight. The unit is designed to be watertight so the Trap/Interceptor/Separator shall be filled with water to the cover frame and hold water with no measurable loss for a period of sixty (60) minutes. Concrete units will be allowed time for complete adsorption within unit, and then be refilled for the sixty (60) minute test. Watertight testing must be completed and approved after installation and before the Trap/Interceptor/Separator is put into service.

**8.19 Trap/Interceptor/Separator Final Inspection:** A final inspection shall be made of the unit before the Washoe County Building Permit is signed off by IVGID. The Trap/Interceptor/Separator shall be accessible, have accessible vented flow control(s), sealed covers, and be connected to all required fixtures ready for service. At the approved final inspection IVGID will issue a Commercial Wastewater Discharge Permit and authorize the unit to be put into service. IVGID will also issue a Customer Information Packet explaining the District policy on use, maintenance, and record keeping.

### **ARTICLE 9. INDIVIDUAL SEWER PUMP STATIONS**

**9.01 General:** If an individual sewage pump station is to be installed outside of the foundation, it falls within the jurisdiction of the District and will be constructed to meet the following specifications. Individual sewage pump stations shall not be used in the District unless the property is too low to be served by gravity to an existing sewer line, the property owner shall install an individual pump station as approved by the District. The property owner shall install the pressure building sewer with his own contractor or employees. However, the District will approve materials and inspect and approve the construction. All pump stations will discharge into a manhole unless otherwise specified by the District. Where individual sewage pump stations are authorized, they shall be designed, constructed, and maintained in conformance with these specifications. District inspection of newly installed pumping facilities shall be completed in accordance with the procedures outlined within this document.

**9.02 The District may periodically inspect any individual sewage pump station to determine if it is being properly maintained.** Where stations are not being maintained in conformance with these specifications, service may be terminated. Resumption of service will not be allowed until all discrepancies are corrected and the District has approved the work. Any expense incurred by the District to discontinue and resume service shall be paid by the property owner at the time of reconnection.

**9.03 Materials:** Unless previously accepted in writing by the District, pressurized pipe from individual sewer pump stations shall be engineered size to provide a minimum velocity of (2') two feet per second, and not less than (2") in diameter. Piping approved by the District is Ring-Tite Class 200 PSI SDR 21 or Iron pipe size (IPS) class 200PSI PE3408/PE4710 tubing SDR11 ASTM D-2737. The 2" discharge piping connection to the pressurized line from the pump station shall be made with only

## **IVGID REQUIREMENTS FOR CONSTRUCTION OF WATER & SEWER**

the IVGID approved fittings for the 2" IPS PE 3408/PE4710. **Solvent welded joints or brass fittings shall not be used.**

- 9.04 Connection Points to IVGID from Sewer lift Stations:** The sewer discharge piping from the lift station shall be 2" HDPE SDR11 piping installed with tracer wire and connected to a 4" SDR 35 gravity sewer clean out by means of a link seal. If the discharge piping is going to be connected, directly to a sewer manhole the manhole must be cored and link sealed. All piping must be fastened to the interior walls of the manhole with approved stainless steel connections or methods approved by the district. All piping and its fittings must allow the discharge flow to match the flow line within the sewer manhole.
- 9.05 Pumps:** A minimum of two pumps shall be provided at each individual sewage pump station. Where pumps are used, they shall be either grinder pumps or non-clog sewage pumps (dual compressor pneumatic ejector shall be utilized only with prior approval by the District) engineered to serve the dwelling and overcome the head pressure within the pressure ejector line.
- 9.06 Valves:** Each pump shall be equipped with a check valve and an isolating gate or ball valve. Valves and check shall be located in the dry chamber area outside of the actually wet well area so repairs can be completed.
- 9.07 Controls and Alarm:** Pumps shall be automatically controlled by the level in the wet well. The lag pump shall be controlled in such a manner that it will automatically take the place of the lead pump in the event of failure. An alternating system shall be installed to balance wear on both pumps. An audible alarm and a red high water level light shall be installed in a moisture proof enclosure adjacent to the station. This light must be visible from the street in public view and approved by the District. This light shall be controlled by a separate level setting above the lag pump control range. Red high water level light can be eliminated if high wet well alarm is monitored by a Security/Monitoring System.
- 9.08 Wet Wells and Storage Chambers:** A minimum of three hundred (300) gallons of storage per living unit shall be provided above the normal pump operation level, variances in storage capacity must be approved by IVGID Compliance. Such storage shall be provided either in the wet well or in an adjacent structure with a drain back feature. Storage is provided primarily to allow continued use during brief outages. Wet wells and storage chambers shall be concrete, polyethylene, or fiberglass. A manhole opening shall be provided into wet wells and storage chambers. The wet well shall be equipped with the required inlets and outlets.
- 9.09 Sewage Pump Station Vault:** An acceptable weather proof, insulated box with adequate waterproof insulation below the box lid directly above the holding tank. The outside bottom of the Sewage Pump Station Vault Tank must be anchored down by means of concrete. Concrete to be installed around the outside bottom of tank to prevent the Sewage Pump Station Tank from floating.
- 9.10 Testing:** Pressurized sewer pipe shall be hydrostatically tested for fifteen minutes (15) at 1.5 times the pump capacity or meet sewer pipe class specifications. Installation standard shall be manufacturer's specifications and shall meet all of the District's installation requirements. Wet well shall be hydrostatically tested for sixty minutes (60) with no loss. All functions of the station will be tested and approved by the District.



## **IVGID REQUIREMENTS FOR CONSTRUCTION OF WATER & SEWER**

### **ARTICLE 10. COMMUNAL UTILITY SYSTEM SPECIFICATIONS**

All communal utility water system specifications must comply to all information provided within this document of specifications. Its encouraged to contact the IVGID compliance Division at 775-832-1246 and schedule a meeting to discuss your project as your project could have additional requirements for the water and sanitary sewer systems.

### **ARTICLE 11. JOINT TRENCHING SPECIFICATIONS**

- 11.01** Joint trenching of utility service lines is allowed; however, jurisdictional standards must be met within the public right-of-way and District easements. All water service(s) shall be installed and maintain a minimum of one foot (1') above and one foot (1') horizontally away from all building sewer on undisturbed soil/shelved. Complying with all current uniform plumbing codes rules and regulations.
- 11.02** All water services lines in joint trenching shall maintain a twelve inch (12") minimum separation at all times and have their own #10 tracer wire attached to the water service line every five feet (5') by means of tape.
- 11.03** Water mains constructed within the public right-of-way and District easements shall be installed twelve inches (12") minimum above the sewer main and a minimum of ten feet (10') horizontally away from the sewer where possible.
- 11.04** Joint trenching is not allowed with the District main systems.

No other utilities shall be installed within three feet (3') horizontally of the District main lines and/or within one foot (1') from service building sewers.

**\*\* OTHER UTILITY AGENCIES MAY HAVE DIFFERENT SEPARATION CRITERIA. PLEASE CHECK WITH ALL AGENCIES PRIOR TO JOINT TRENCHING.**

### **ARTICLE 12. IVGID APPROVED INSTALLATION DETAILS**

The construction details shown below were provide by IVGID to help you understand what is needed for your project to pass the required field inspections being performed by the Incline Village General Improvement District Compliance Inspector(s).

# IVGID REQUIREMENTS FOR CONSTRUCTION OF WATER & SEWER

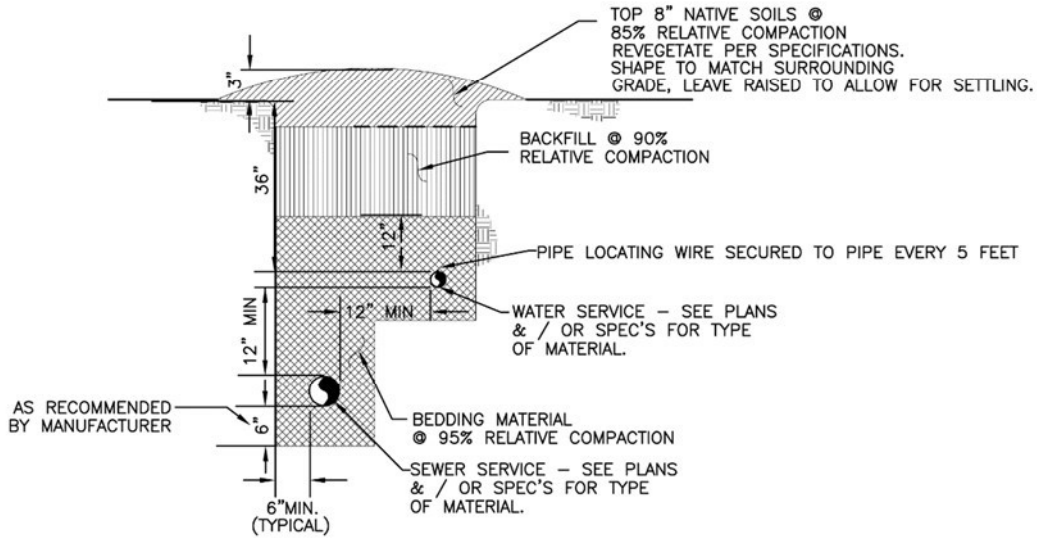

**NOTES:**

1. COVER TO BE MINIMUM OF 36 INCHES FROM TOP OF WATER PIPE TO FINISHED SURFACE GRADE.
2. BOTTOM OF TRENCH SHALL BE LEVEL AND SMOOTH.
3. EXCAVATE AS NEEDED TO MAINTAIN 6" MINIMUM BEDDING UNDER PIPE AT COUPLINGS AND HUBS OF FITTINGS.
4. ALL BEDDING MATERIAL SHALL BE COMPACTED PRIOR TO SHAPING TRENCH & INSTALLATION OF PIPE.
5. ALL PROTRUDING ROCKS TO BE REMOVED.

JOINT TRENCH  
NON-PAVED AREAS  
NOT TO SCALE

Project No. \_\_\_\_\_  
DATE: 15 DEC 2014  
SCALE: N.I.S.  
DRAWN: MTL DESIGN:  
APPROVED: \_\_\_\_\_ DATE: \_\_\_\_\_

**INCLINE VILLAGE GENERAL IMPROVEMENT DISTRICT**  
1220 Sweetwater Rd.; Incline Village, Nevada 89451 Phone 775-832-1267  
**JOINT WATER/SEWER SERVICE DETAIL**

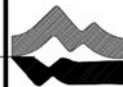

# IVGID REQUIREMENTS FOR CONSTRUCTION OF WATER & SEWER

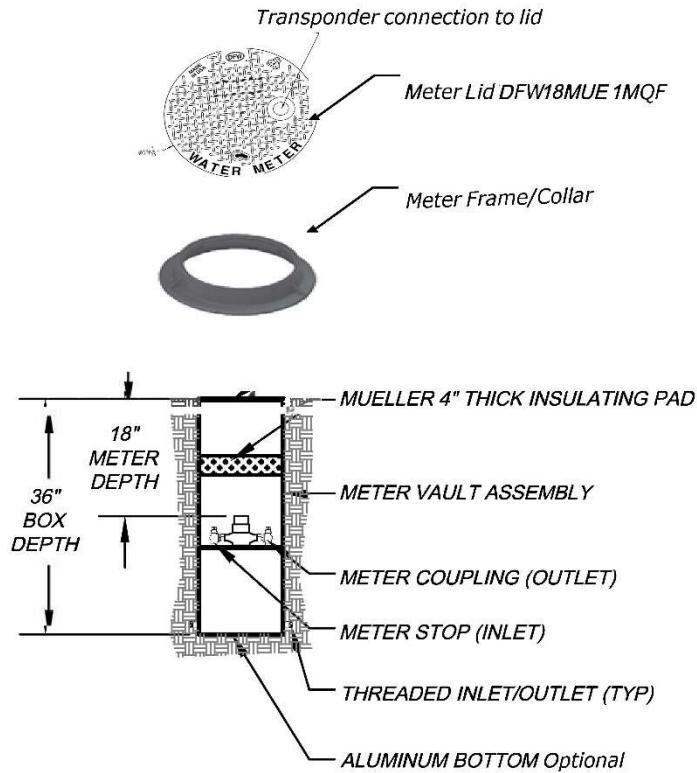

**METER VAULT ASSEMBLY:**

**3/4" AND 1" METER - Mueller EZ Vault Meter setter with no Bypass**

**1.5" AND 2" METER - MUELLER EZ-VAULT METER SETTER (WITH NO BYPASS)**

*IVGID may except other products as approved by District Engineering Manager*

Project No. _____ DATE 15 MAY 2012 SCALE: N.T.S. DRAWN: MTL DESIGN: MC APPROVED: _____ DATE: _____	<b style="font-size: 1.2em;">INCLINE VILLAGE GENERAL IMPROVEMENT DISTRICT</b> 1220 Sweetwater Rd.; Incline Village, Nevada 89451 Phone 775-832-1267 <b style="font-size: 1.1em;">METER PIT FOR NON-TRAFFIC AREAS</b>	
--	--	---



# IVGID REQUIREMENTS FOR CONSTRUCTION OF WATER & SEWER

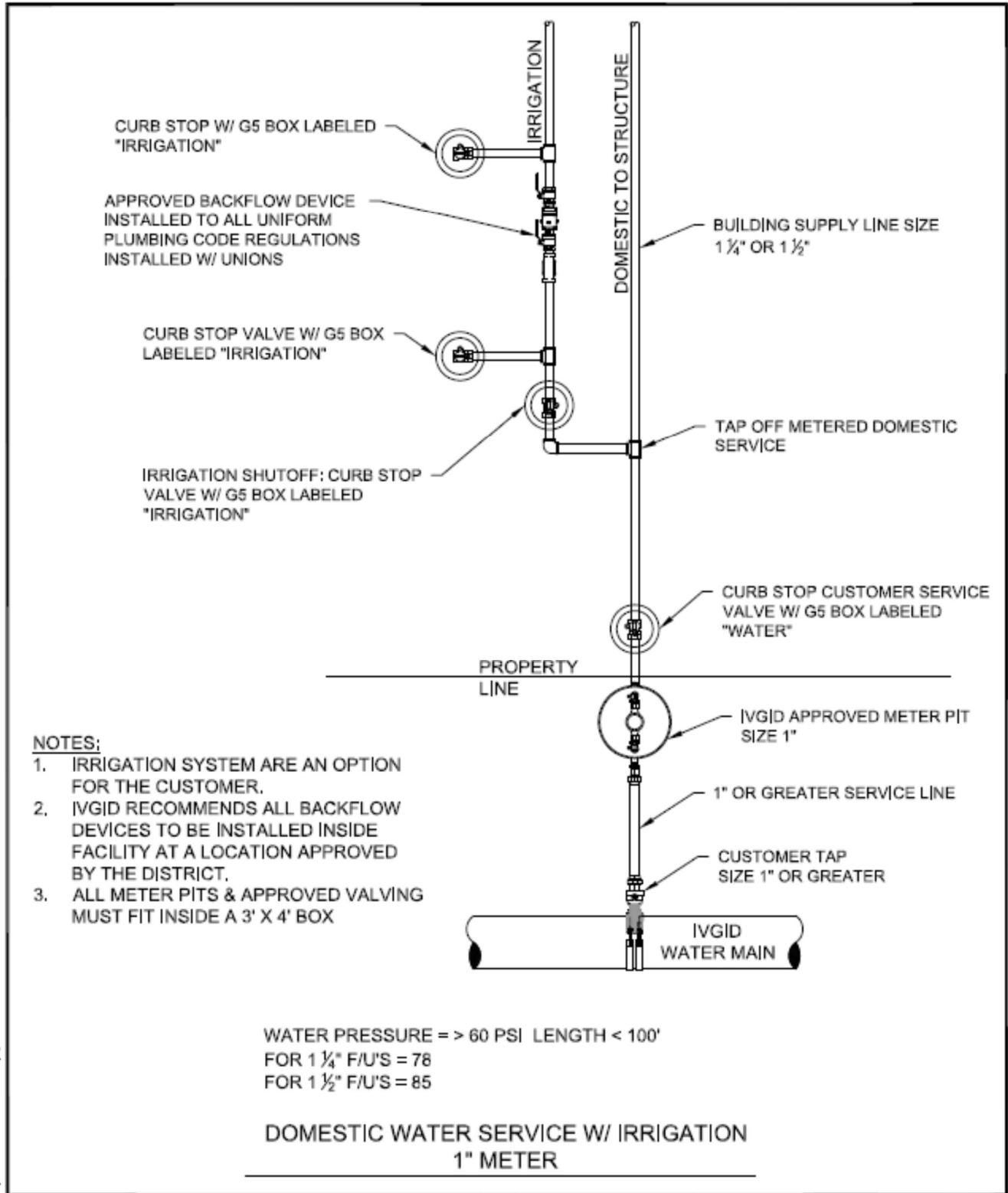

WATER PRESSURE = > 60 PSI LENGTH < 100'  
 FOR 1 1/4" F/U'S = 78  
 FOR 1 1/2" F/U'S = 85

PROJECT	STD DETAILS				
SCALE	NTS				
DATE	12/8/22				
SHEET	1	DSGN	DWG	CHK	APP'D BY:

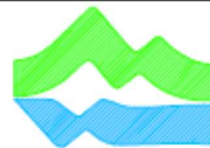

**INCLINE VILLAGE**  
**GENERAL IMPROVEMENT**  
**DISTRICT**  
 1220 SWEETWATER RD.  
 INCLINE VILLAGE, NV 89431  
 P: 877.468.4307

# IVGID REQUIREMENTS FOR CONSTRUCTION OF WATER & SEWER

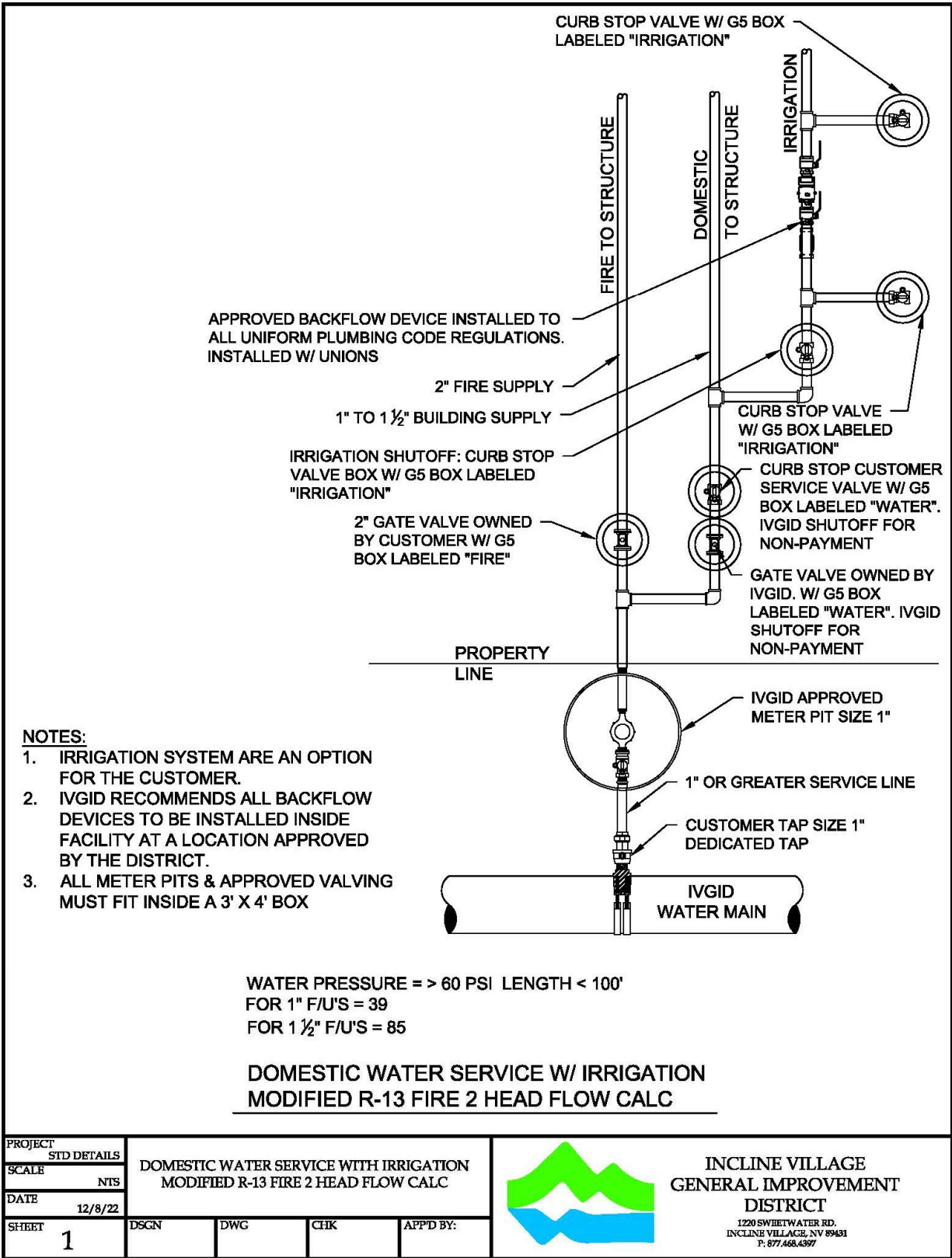

- NOTES:**
1. IRRIGATION SYSTEM ARE AN OPTION FOR THE CUSTOMER.
  2. IVGID RECOMMENDS ALL BACKFLOW DEVICES TO BE INSTALLED INSIDE FACILITY AT A LOCATION APPROVED BY THE DISTRICT.
  3. ALL METER PITS & APPROVED VALVING MUST FIT INSIDE A 3' X 4' BOX

WATER PRESSURE = > 60 PSI LENGTH < 100'  
 FOR 1" F/U'S = 39  
 FOR 1 1/2" F/U'S = 85

### DOMESTIC WATER SERVICE W/ IRRIGATION MODIFIED R-13 FIRE 2 HEAD FLOW CALC

I:\Engineering\AUTOCAD\2025 STD DETAILS\Updated Details\Water

PROJECT	STD DETAILS			
SCALE	NTS			
DATE	12/8/22			
SHEET	DSGN	DWG	CHK	APP'D BY:
1				



**INCLINE VILLAGE  
 GENERAL IMPROVEMENT  
 DISTRICT**  
 1220 SWEETWATER RD.  
 INCLINE VILLAGE, NV 89431  
 P: 877.468.4397

# IVGID REQUIREMENTS FOR CONSTRUCTION OF WATER & SEWER

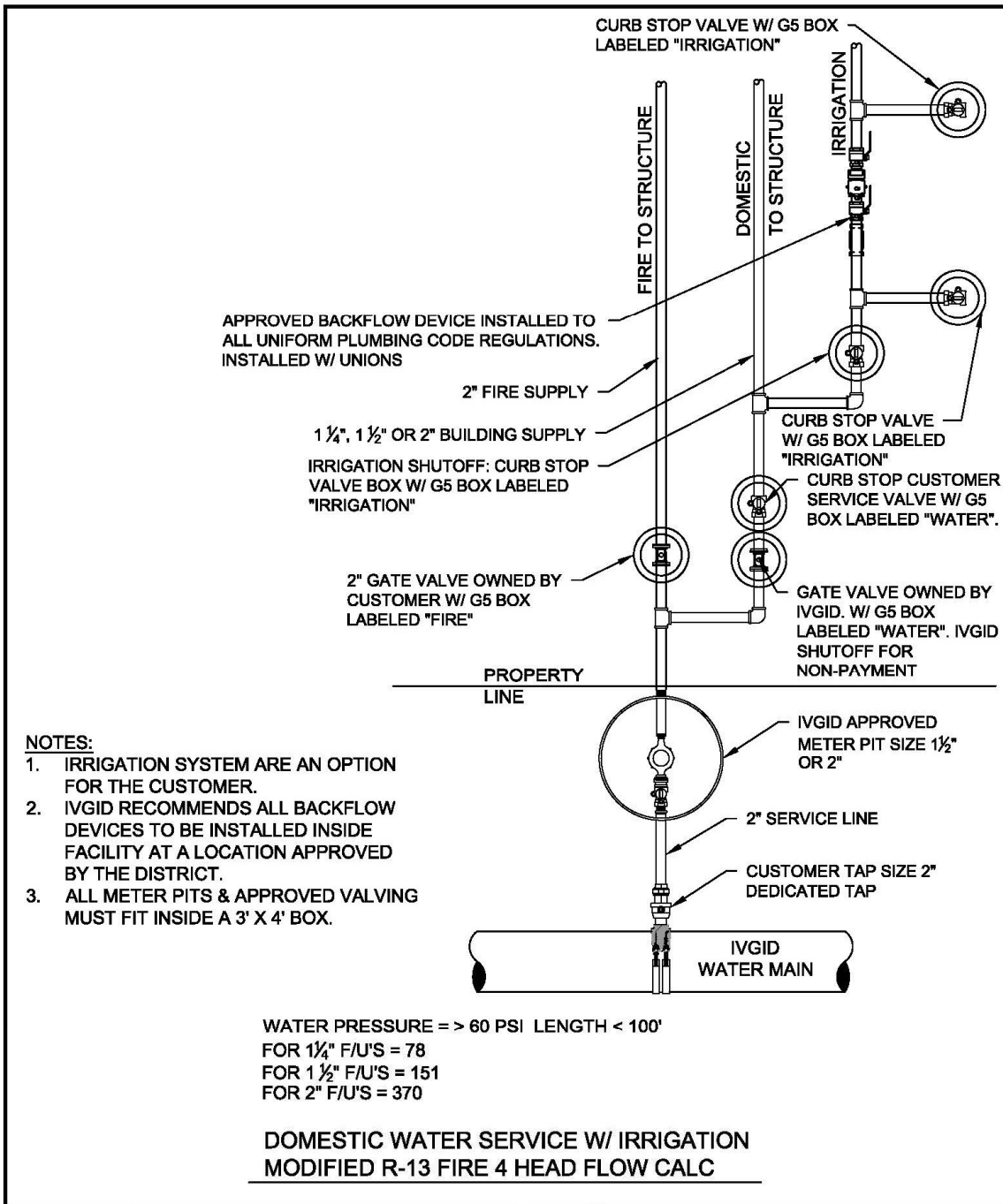

**NOTES:**

1. IRRIGATION SYSTEM ARE AN OPTION FOR THE CUSTOMER.
2. IVGID RECOMMENDS ALL BACKFLOW DEVICES TO BE INSTALLED INSIDE FACILITY AT A LOCATION APPROVED BY THE DISTRICT.
3. ALL METER PITS & APPROVED VALVING MUST FIT INSIDE A 3' X 4' BOX.

PROJECT	STD DETAILS			
SCALE	DOMESTIC WATER SERVICE WITH IRRIGATION MODIFIED R-13 FIRE 4 HEAD FLOW CALC			
DATE	12/8/22			
SHEET	DSCGN	DWGN	CHK	APP'D BY:
1				



**INCLINE VILLAGE  
 GENERAL IMPROVEMENT  
 DISTRICT**  
 1220 SWEETWATER RD.  
 INCLINE VILLAGE, NV 89431  
 P: 877.468.4397

# IVGID REQUIREMENTS FOR CONSTRUCTION OF WATER & SEWER

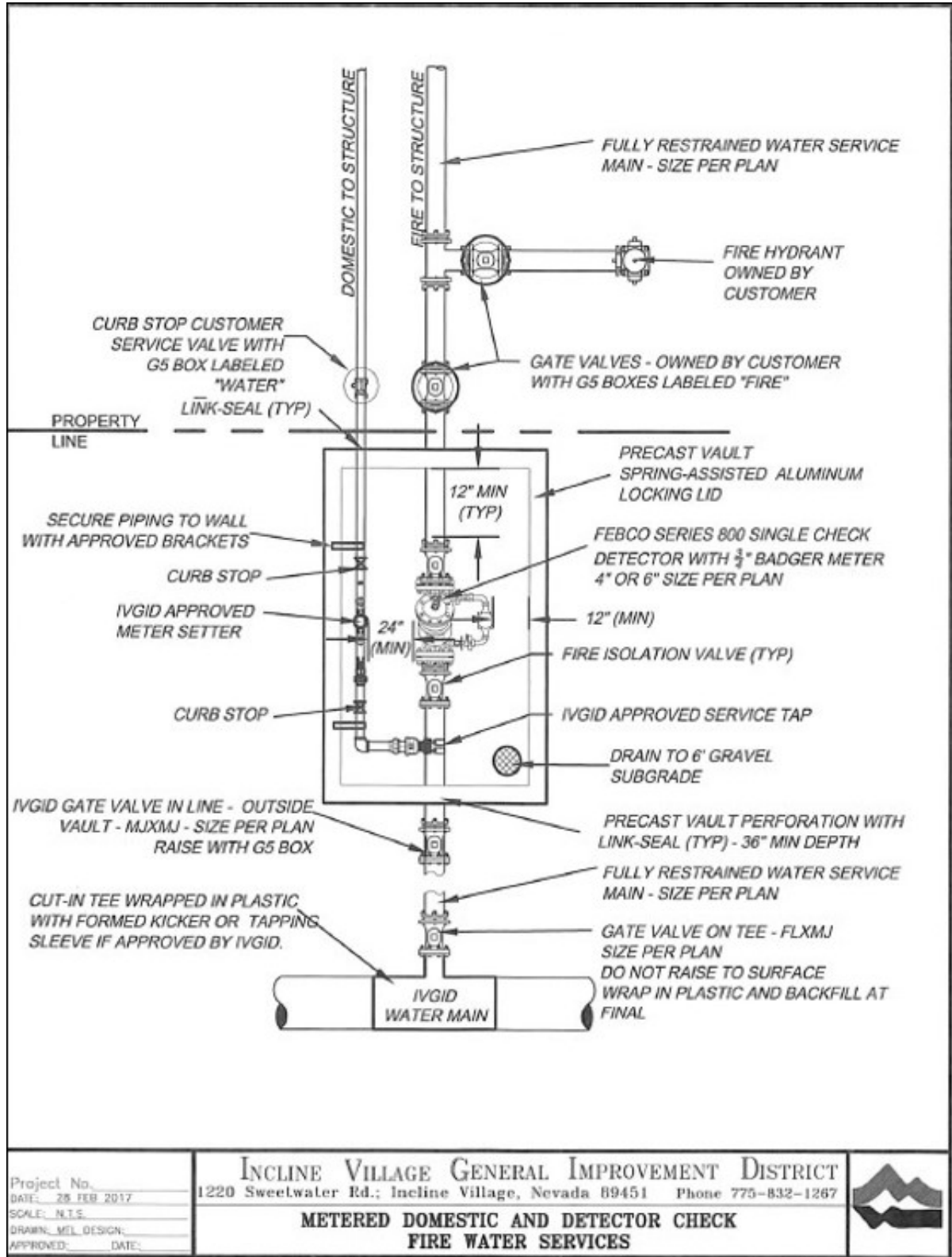

Project No. \_\_\_\_\_  
 DATE: 28 FEB 2017  
 SCALE: N.T.S.  
 DRAWN: MEL DESIGN  
 APPROVED: \_\_\_\_\_ DATE: \_\_\_\_\_

**INCLINE VILLAGE GENERAL IMPROVEMENT DISTRICT**  
 1220 Sweetwater Rd.; Incline Village, Nevada 89451 Phone 775-832-1267

**METERED DOMESTIC AND DETECTOR CHECK  
 FIRE WATER SERVICES**







**IVGID REQUIREMENTS FOR CONSTRUCTION OF WATER & SEWER**

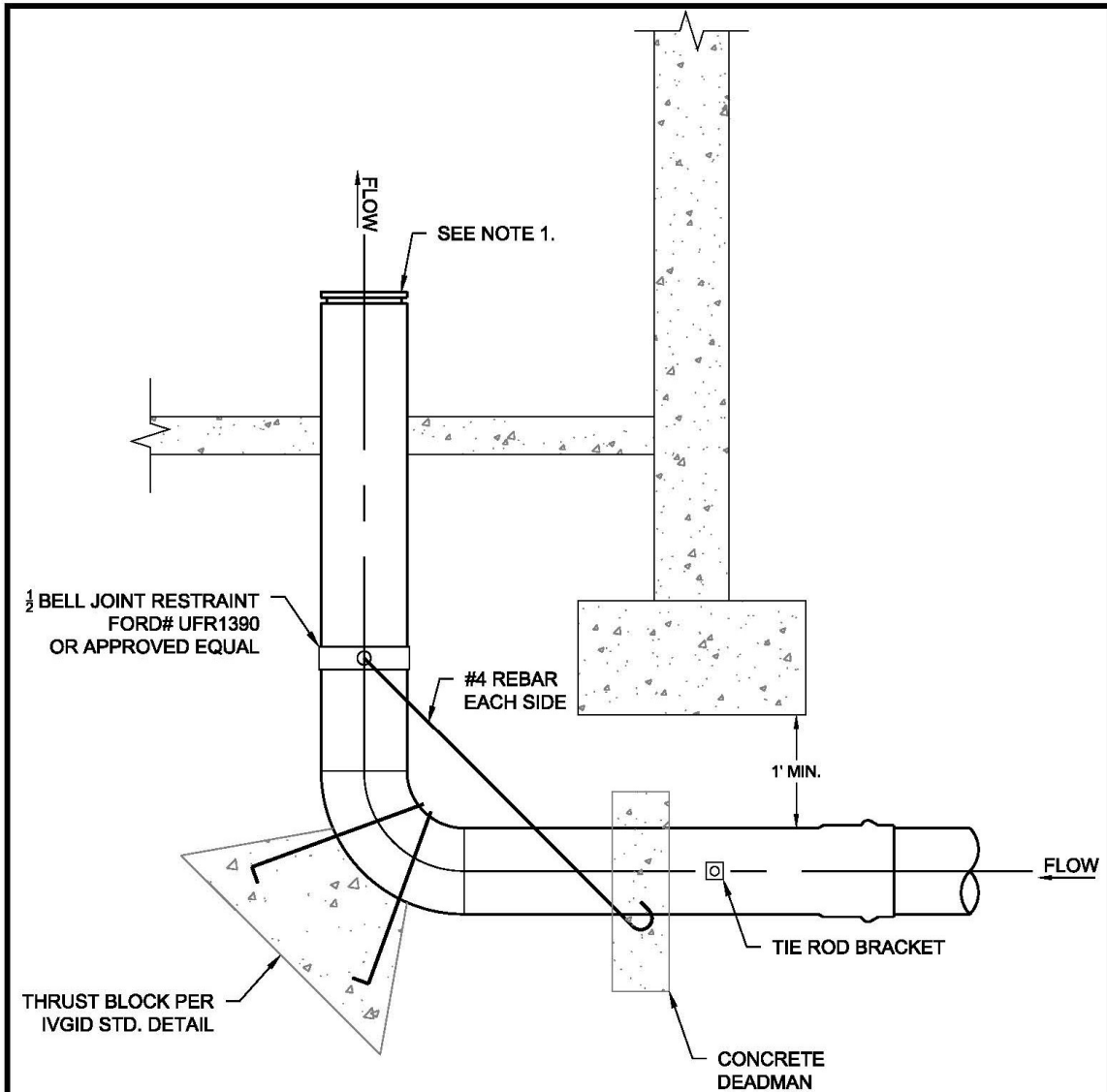

- NOTES:**  
 1. ONE PIECE STAINLESS STEEL RISER. SEE IVGID SPEC SHEET.

U:\Engineering\AUTOCAD\Utility\Water\standard details\IVGID Water Services\FIRE RISER.dwg

Project No. _____ DATE: 19 FEB 2020 SCALE: N.T.S. DRAWN: NPC DESIGN: APPROVED: _____ DATE: _____	<b>INCLINE VILLAGE GENERAL IMPROVEMENT DISTRICT</b> 1220 Sweetwater Rd.; Incline Village, Nevada 89451 PHONE 775-832-1287 <b>1-PIECE FIRE RISER</b>	
--	---	---

**IVGID REQUIREMENTS FOR CONSTRUCTION OF WATER & SEWER**

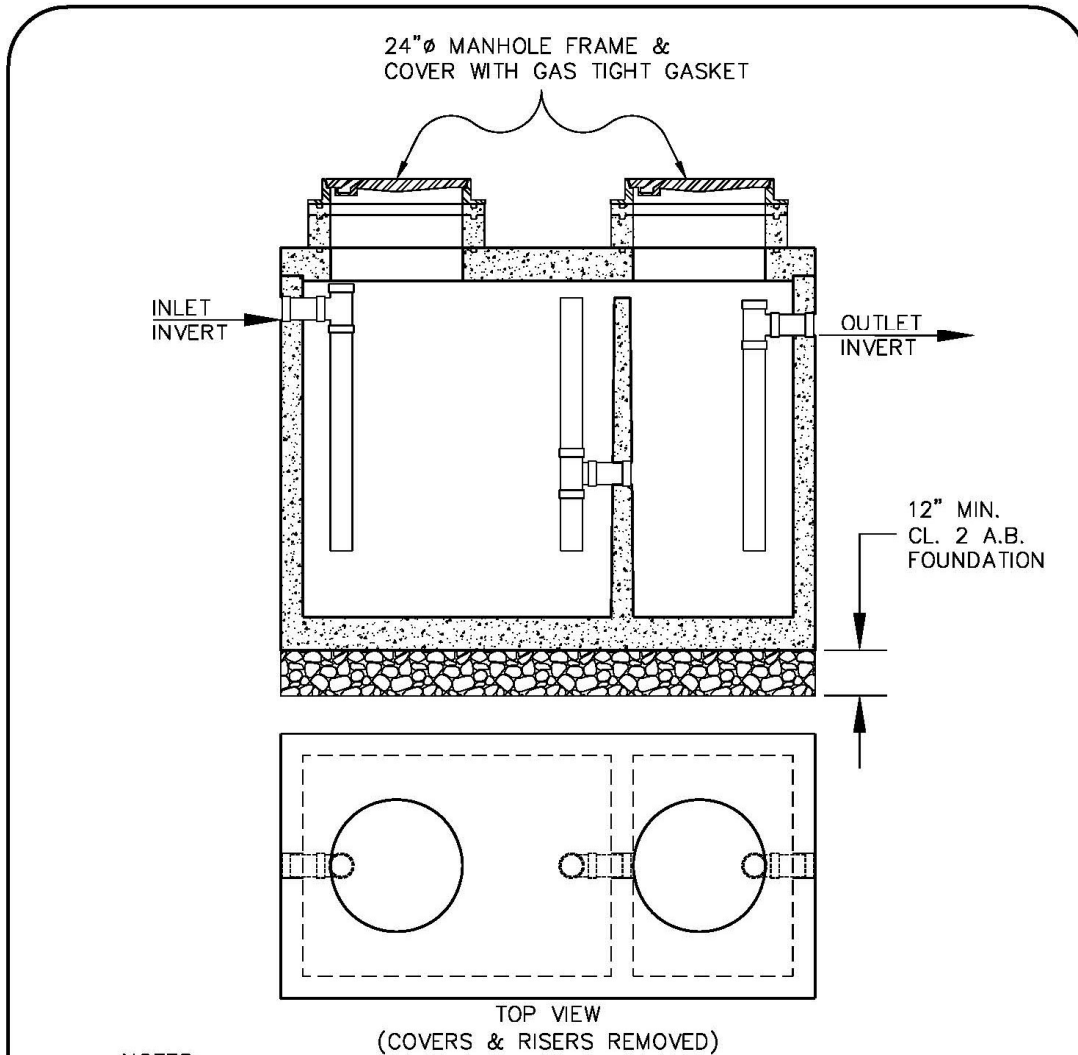

**NOTES:**

1. MINIMUM CAPACITY 500 GALLONS.
2. VAULT AND MANHOLE DESIGN LOAD: H-20 TRAFFIC LOADING.
3. 24"Ø MANHOLE FRAME & COVERS: PER IVGID STD. DETAIL. ADD THIRD MANHOLE OVER CENTRAL STANDPIPE FOR INTERCEPTORS LARGER THAN 1,000 GALLONS.
4. SET VAULT LEVEL
5. RAMNEK PRIMER AND SEALANT SHALL BE APPLIED TO BOTH SURFACES AT ALL JOINTS.

SCALE: N.T.S.

	<p><b>GREASE INTERCEPTOR</b></p>	
---	--------------------------------------	--

**IVGID REQUIREMENTS FOR CONSTRUCTION OF WATER & SEWER**

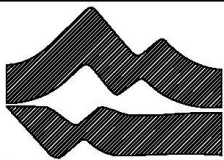
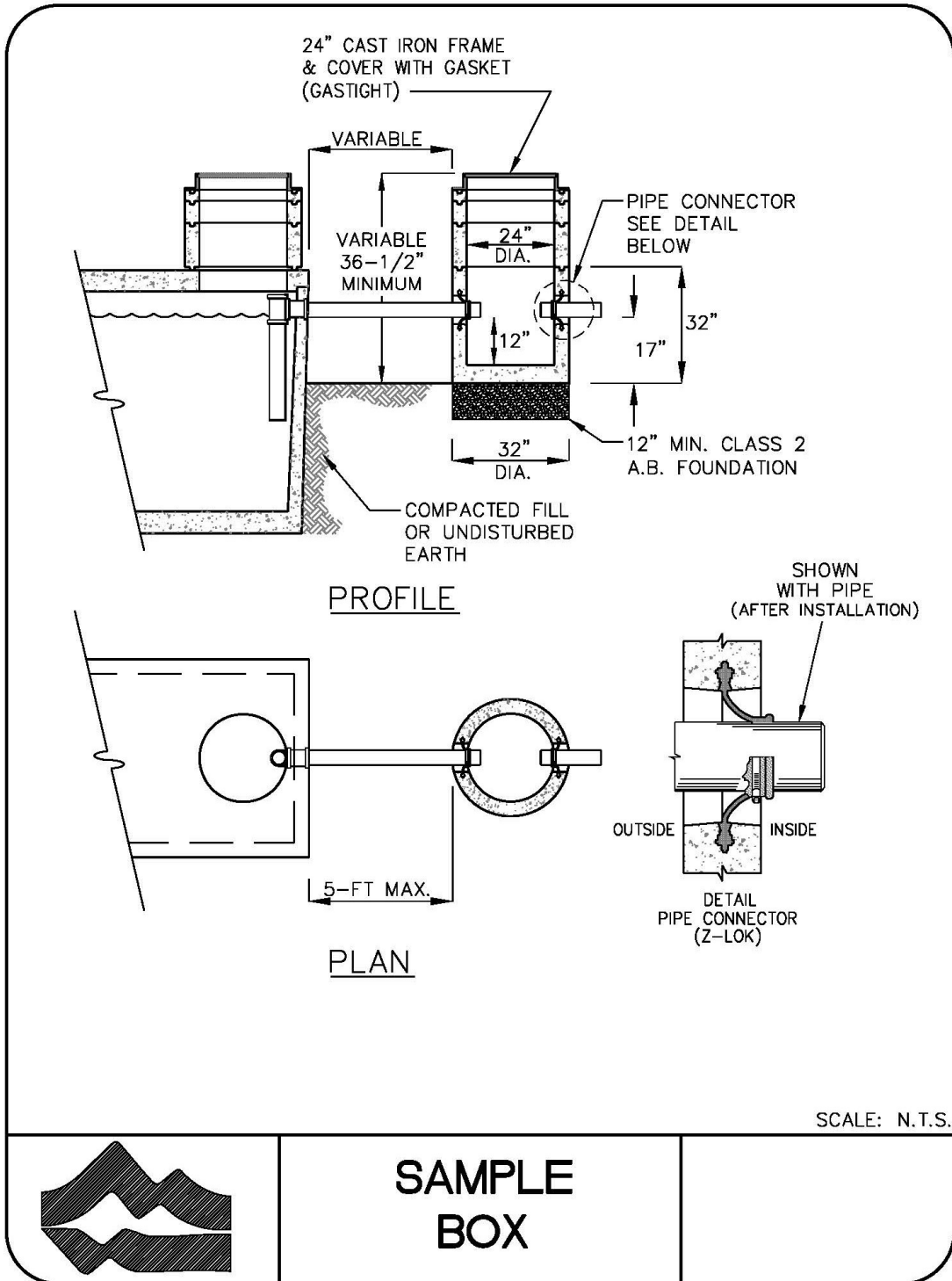

**SAMPLE  
BOX**

**IVGID REQUIREMENTS FOR CONSTRUCTION OF WATER & SEWER**

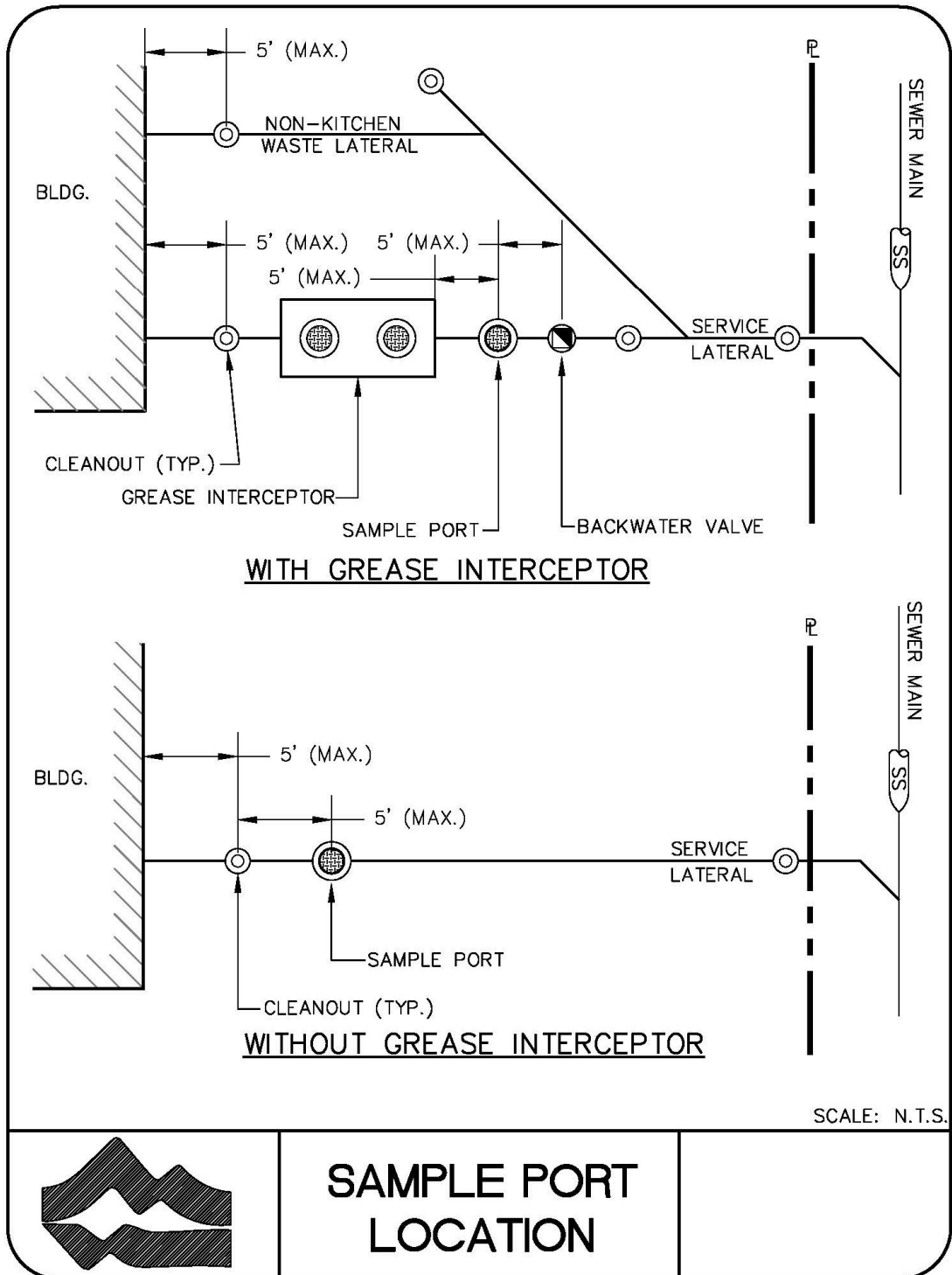

# IVGID REQUIREMENTS FOR CONSTRUCTION OF WATER & SEWER

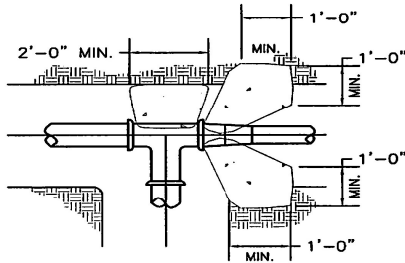

REDUCERS - PLAN

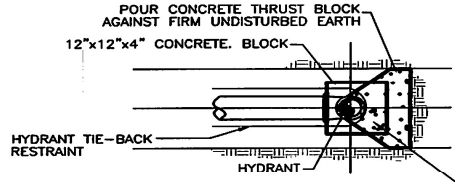

FIRE HYDRANT  
END CAP DETAIL - PLAN

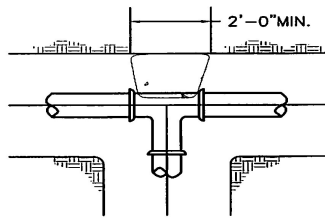

TEES - PLAN

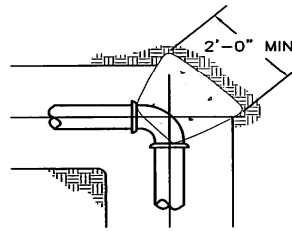

ALL BENDS - PLAN

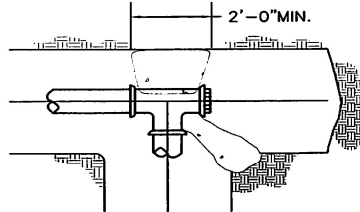

TEE W/PLUG

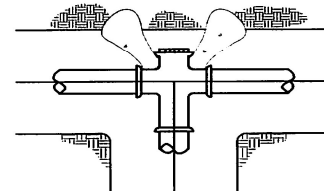

CROSS W/PLUG

**NOTE:**

1. ALL FITTINGS TO BE WRAPPED IN PLASTIC.
2. CONCRETE SHALL NOT TOUCH PIPE OR BOLTS.
3. THRUST BLOCKS TO BE 6.25 SACK, 4000 PSI (MIN) STRENGTH CONCRETE

**NOTE:**

THIS DETAIL APPLIES FOR ALL FITTINGS.

SIDE WALLS OF TRENCH

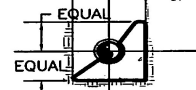

TYPICAL SECTION

BEARING AREA OF THRUST BLOCKS-SQ.FT.						
TYPE OF FITTING	90° BEND	45° BEND	1 1/4" OR 22-1/2" BEND	TEE OR DEAD END	TEE WITH PLUG	CROSS W/PLUG
4"	2	1	1	2	2	2
6"	4	4	2	4	4	4
8"	7	4	2	5	7	7
10"	12	6	3	8	12	12
12"	16	10	5	12	16	16
14"	20	12	6	14	20	20
16"	27	15	8	18	27	27
18"	45	25	13	32	45	45
24"	65	35	18	46	65	65

HORIZONTAL THRUST BLOCK DETAILS

NOT TO SCALE

# IVGID REQUIREMENTS FOR CONSTRUCTION OF WATER & SEWER

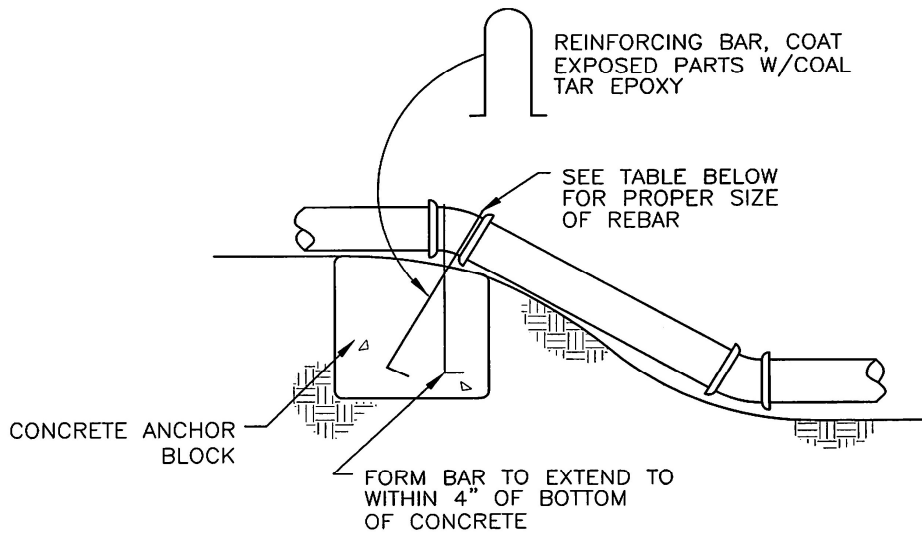

### ELEVATION

1. ALL FITTINGS TO BE WRAPPED IN PLASTIC.
2. CONCRETE SHALL NOT TOUCH PIPE OR BOLTS.
3. THRUST BLOCKS TO BE 6.25 SACK, 4000 PSI (MIN) STRENGTH CONCRETE

REQUIRED ANCHOR BLOCK - CUBIC FEET CONCRETE					
PIPE SIZE	4"	6"	8"	10"	12"
11-1/4" BEND	2	7	13	20	31
22-1/2" BEND	5	14	26	40	59
45° BEND	10	28	52	80	117
BAR SIZE (MINIMUM)	#4	#4	#5	#5	#8

### VERTICAL THRUST ANCHORAGE

NOT TO SCALE

## IVGID REQUIREMENTS FOR CONSTRUCTION OF WATER & SEWER

Typical approved wet well, four float system with grinding, alternating pumps. Three Hundred (300) gallons of storage must be provided above the highest float (High Water Float Switch) any variances to this must be approved by the IVGID Compliance Department. Wet well Storage Chambers must be constructed of Concrete, Polyethylene, or fiberglass equipped with the required inlets and outlets. Each wet well shall be equipped with an approved check or isolating valve.

### TYPICAL APPLICATIONS

### FLOAT BRACKET

PAGE  
2

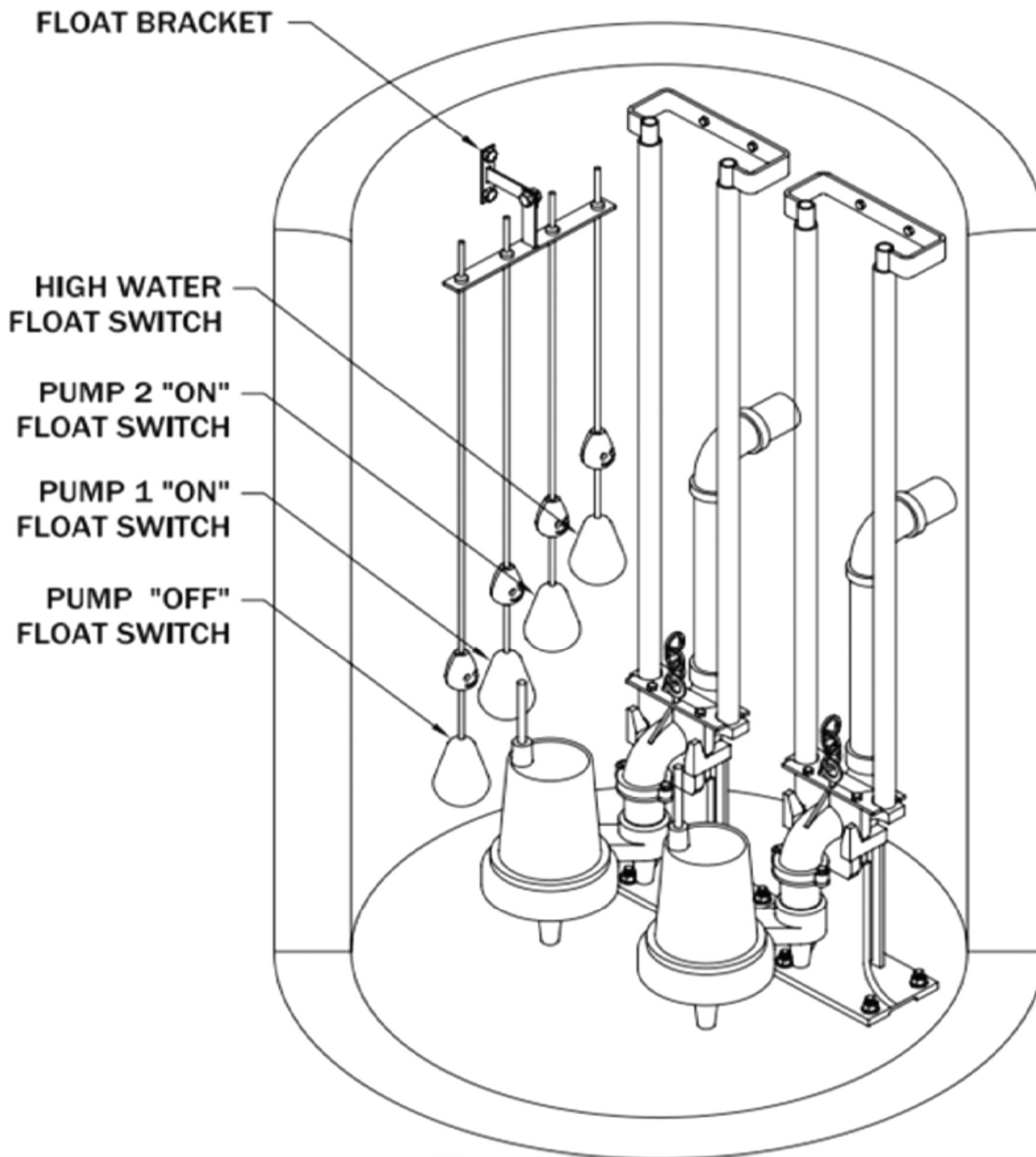



## **IVGID REQUIREMENTS FOR CONSTRUCTION OF WATER & SEWER**

Please direct any questions to IVGID Compliance. Thank you for your cooperation.

**Kate Nelson**

**Engineering Manager**

775-832-1372 Office  
npc@ivgid.org

**Tim Buxton**

**Chief Inspector**

775-832-1246 Office  
775-354-5664 Cell  
tlb@ivgid.org

**Drew Morris**

**Inspector**

775-832-2014 Office  
775-745-7577 Cell  
dnm@ivgid.org

**Jeff Donahue**

**Inspector**

775-832-1314 Office  
775-313-4088 Cell  
jad@ivgid.org

**Jesse Malsam**

**Inspector**

775-832-1252 Office  
775-833-8321 Cell  
jlm2@ivgid.org

**Inspection Hotline**

**775-832-1224**

**All inspections require 48-hour notice**